



2021 British Truck Racing Championship



Organised by:

The British Automobile Racing Club

Thruxton Circuit, Andover, Hampshire, SP11 8PN

Published 28 May 2021
Inc. Bulletins 1 & 2

CONTENTS

1 Sporting Regulations - General

- 1.1 Title & Jurisdiction
- 1.2 Officials
- 1.3 Competitor Eligibility
- 1.4 Registration
- 1.5 Championship Rounds
- 1.6 Scoring
- 1.7 Awards

2 Sporting Regulations - Championship Race Meetings & Race Procedures

- 2.1 Entries
- 2.2 Briefings
- 2.3 Qualification Practice
- 2.4 Races
- 2.5 Starts
- 2.6 Session Red Flag
- 2.7 Pits, Paddock & Pit Lane Procedures
- 2.8 Race Finishes
- 2.9 Results
- 2.10 Timing Modules
- 2.11 Qualification Races
- 2.12 Operation of Safety Car

3 Specific Championship Regulations

4 Championship Race Penalties

5 Technical Regulations

- 5.1 Introduction
- 5.2 General Description
- 5.3 Safety Requirements
- 5.4 General Technical Requirements
- 5.5 Chassis
- 5.6 Bodywork
- 5.7 Engine
- 5.8 Suspension
- 5.9 Transmission
- 5.10 Electrics
- 5.11 Brakes
- 5.12 Wheels/Steering
- 5.13 Tyres
- 5.14 Weight
- 5.15 Fuel Tank / Fuel
- 5.16 Silencing
- 5.17 Numbers and Decals
- 5.18 Maximum Road Speed
- 5.19 Smoke

6 Appendices

- 6.1 Race Organising Club
- 6.2 Contacts
- 6.3 Commercial Undertakings
- 6.4 Penalties

1. SPORTING REGULATIONS – GENERAL

1.1 TITLE & JURISDICTION:

The British Truck Racing Championship is organised and administered by the British Automobile Racing Club (BARC) and promoted in conjunction with Truck Sport, in accordance with the General Regulations of the Motorsport UK Association Limited (incorporating the provisions of the International Sporting Code of the FIA) and these Championship Regulations.

Motorsport UK Championship Permit No:	CH2021/R040 (A)
Race Status:	National (Truck)
Motorsport UK Championship Grade:	Grade A

1.2 OFFICIALS:

1.2.1	Co-ordinator:	David Wheadon
1.2.2	Licensed Eligibility Scrutineer:	Terry Cox
1.2.3	Championship Stewards:	Dale Wells Dennis Carter Pat Blakeney Guy Woodward

Any three of the Championship Stewards may sit to make a decision. In accordance with G2.7, Championship Stewards may only adjudicate on any disputes, irregularities or appeals arising from the approved Championship regulations. Under G2.7.1, Championship Stewards are also empowered to consider any request from the Championship co-ordinator to penalise any Competitor for any breach of Championship regulations after holding a formal hearing to impose a penalty in accordance with C.2.1.1 (subject to the rights of appeal provided for in Section C). Under W2.2.1, the Championship Stewards can only adjudicate upon any disputes, irregularities or appeals arising from the approved Championship Regulations. They are also empowered to consider any request from the Championship Co-ordinator to penalise any Competitor for breach of Championship Regulations and after holding a formal hearing, to impose a penalty in accordance with C.2.1, subject to the rights of appeal to the MSC provided in Section C.

1.2.4	Championship Clerks of the Course:	David Cartwright / Peter Roberts
-------	------------------------------------	----------------------------------

1.3 COMPETITOR ELIGIBILITY:

1.3.1 Entrants must:

- (a) be current members of the British Truck Racing Association (BTRA) and
- (b) be Registered for the Championship and
- (c) be in possession of a valid Motorsport UK Entrants Licences.

1.3.2 Drivers and Entrant/Drivers must:

- (a) be current racing members of the BARC and
- (b) be Registered for the Championship and
- (c) be in possession of valid Competition Race National status Licence, as a minimum or
- (d) Or be in possession of the highest grade of National Race licence or valid FIA International Licence, together with their ASN's written consent ((H)25.2. and FIA ISC Article 2.3.7.b applies).

- (e) If participation in the Championship requires absence from education a driver, in full time school education is required to have the approval of their head teacher and a letter stating such approval from their school in order to fulfil registration for the Championship. A driver shall not take time out of their education to participate in motor sport without the prior written approval of their education establishment.

1.3.3 All necessary documentation must be presented for checking at all rounds when signing-on. This will include both the competition licence and club membership card.

1.4 REGISTRATION:

1.4.1 All competitors must register for the Championship by returning the Registration Form with the Registration Fee to the Co-ordinator prior to the closing date for entries for the first round being entered. Registrations are not automatically accepted and may be revoked at any time by the Organisers.

1.4.2 There is no Registration Fee.

1.4.3 Registration numbers issued will be the permanent Competition numbers for the Championship season.

1.5 CHAMPIONSHIP EVENTS:

The Championship is scheduled to be contested over seven meetings as follows:

EVENT	DATE	ROUNDS	VENUE	CLUB
1	5/6 June	01 - 05	Brands Hatch	BARC
2	3/4 July	11 - 15	Thruxton	BARC
3	21/22 August	16 - 20	Donington Park	BARC
4	11/12 September	21 - 25	Zolder	FIA ETRC
5	18/19 September	26 - 30	Snetterton	BARC
6	9/10 October	31 - 35	Pembrey	BARC
7	6/7 November	36 - 40	Brands Hatch	BARC

1.5.1 In accordance with Motorsport UK regulation D11 the organisers reserve the right to amend the published list of dates and rounds, in which case, all registered competitors will be informed of the amendments by Official Bulletins posted to the address specified on the Official Registration Form.

1.6 SCORING:

1.6.1 Points will be awarded to Competitors listed as classified finishers in each Class within the Final Results as follows:

1st - 15, 2nd - 14, 3rd - 13, going down in single point intervals to 15th place - 1. There will be an additional point awarded for the fastest lap in each race.

The number of points scoring races to be held at each meeting will be confirmed by a bulletin at each meeting. In the event that the number of entries exceeds the number permitted to race by the track licence or the number of trucks available to race has declined to such a point the organisers may elect to run a different race format. This revised format will be given to competitors by means of a bulletin at the meeting.

1.6.2 The totals from all qualifying Events run will determine final Championship points and positions.

1.6.3 Ties shall be resolved using the formula in W1.3.4, in the current Motorsport UK Yearbook.

1.6.4 Where the race distance has been reduced in accordance with article 2.6 below, it shall still count as a full-points scoring round.

- 1.6.5 Competitors not registered for the Championship may be permitted on an individual round basis and:
- a) will be deemed "Guest Competitors".
 - b) will not score points and for the purpose of points scoring will be ignored.
 - c) will be allowed to take their place on the podium and qualify for any Event awards.
 - d) must comply with the eligibility criteria as prescribed in article 1.3 above, with the exception of 1.3.1 (a & b) and 1.3.2 (a & b) as appropriate.

1.7 AWARDS:

1.7.1 All awards are to be provided by the BARC.

1.7.2 Per Event: A garland will be presented to the winner of each race.
Trophies will be awarded to 1st, 2nd & 3rd in each class.

1.7.3 Championship: A trophy will be awarded to those finishing 1st, 2nd & 3rd in each Class.

1.7.4 Presentations:

Awards will be presented at the end of each Event and/or at the end of the Championship at the designated presentation ceremony. Attendance at any such ceremony is mandatory and failure to attend may result in the loss of all awards and referral to the Championship Stewards for consideration of a penalty.

1.7.5 Entertainment Tax Liability:

Prize money and Bonuses shall be posted to the Entrants within thirty days of the results being declared final after each Event. In accordance with current government legislation, the BARC is legally obliged to withhold tax at the basic rate on all payments to non-UK resident sportsmen/women and account to HMRC using form FEU1, the quarterly return of payments made to non-resident entertainers and sportsmen/women. That is, those persons who do not have a normal permanent residence in the UK and the UK does not include the Isle of Man, Channel Islands or Eire. This means that, as the organiser, the BARC is required to deduct tax at the current rate applicable from any such payments they may make to non-UK residents. Under certain circumstances, it may be possible for competitors to enter into an agreement with the Inland Revenue to limit the tax withheld. Any application for such an arrangement must be made in writing and not later than 30 days before the payment is due.

For further information contact:

HMRC Personal Tax International, Foreign Entertainers Unit, St John's House, Merton Road, Liverpool L75 1BB, Tel: 01514 726488, Fax: 01514 726483.

1.7.6 Title to all Trophies:

If Provisional Results or Championship Tables are revised after any presentations and these revisions affect the distribution of awards the Competitors concerned must return them to the organisers in good condition within 7 days.

2. CHAMPIONSHIP EVENT MEETINGS & RACE PROCEDURES

2.1 ENTRIES:

- 2.1.1 Competitors are responsible for sending in correct and complete entries with the correct entry fee prior to the closing date for entries before each Event.
- 2.1.2 Incorrect or incomplete entries (Including driver to be nominated entries) are to be held in abeyance until they are complete and correct and the date of receipt for acceptance of entry purposes shall be the date on which the Meeting Organiser receives the missing or corrected information or fee.
- 2.1.3 Any withdrawal of Entry or Driver/Truck changes made after acceptance of any entry must be notified to the Meeting Organisers in writing. D25.1.13 applies. Withdrawals/refunds can only be made on an individual event basis, full season entry will not be refunded.
- 2.1.4 The Entry Fee for the full Championship is £5,440.00. If entering for a single event, the fee will be £995.00 subject to availability.
- 2.1.5 In the case of having more entries than are permitted by the track licence either the race format will be revised in accordance with CR 3.1.5 or reserves will be listed in the Final List of Entries published with Final Instructions or in a Bulletin.
- 2.1.6 The priority on entries accepted from both classes will be according to the following:
- Those who have made a legitimate complete full season entry.
 - Those who have competed in the greatest number of events in the year.
 - Those who have scored the greatest number of championship points within the year.

At the first event of the year the selection of entries will be by:

- Those who have made a legitimate complete full season entry.
- Those who completed the greatest number of events in the previous season of the Championship.
- Those who scored the greatest number of points in the previous season of the Championship.

2.2 BRIEFINGS:

Organisers should notify Competitors of the times and locations for all briefings in the Final Instructions for the meetings. Competitors must attend all briefings.

2.3 QUALIFICATION PRACTICE:

- 2.3.1 Should any Practice session be disrupted the Clerk of the Course shall not be obliged to resume or re-run the session; the decision of the Clerk of the Course shall be final.
- 2.3.2 Each driver shall complete a minimum of 3 laps in the truck to be raced and in the correct session, in order to qualify (Motorsport UK Regulations Q.12.9.7).

2.4 RACES:

Should any race be disrupted the Clerk of the Course shall not be obliged to resume or re-run the race (Q.12.15) in addition article 1.6.4 above applies.

2.5 STARTS:

- 2.5.1 All trucks will be released to form up on the grid prior to the start in formation as specified on the grid sheet.
- 2.5.2 The starting grid will be formed with Class 1 ahead of Class 2 with a three (3) grid row gap between the two classes. In accordance with Motorsport UK Regulation Q.14, the gap will replace the time delay detailed within Motorsport UK Regulation Q.12.12.3. The start will be via a Rolling start. The countdown procedure and audible warning sequence prior to the start of the race shall be:

SIGNAL	INSTRUCTION
1 Minute	Start engines and clear the grid
30 Seconds	Be prepared for start of the Green Flag Lap
Green Flag	If there are two groups, group one will be waved off approximately 10 seconds prior to group two, to then complete one lap of the circuit at approximately 60 k.p.h. forming into grid order after 75% of the lap is completed
Red Lights Off	As group one is approaching the grid the red lights will be on and when the starter is happy with the formation the lights will be extinguished to indicate the start
National Flag	In the event of their also being a second group that group will be three (3) grid rows behind the first group and the signal to start shall be the dropping of the National flag

- 2.5.3 Any truck removed from the grid after the 1-minute stage or driven into the pits on the Green Flag lap shall be held in the pit lane and may start the race after the last truck, in any following group, has taken the start. It is not safe to send a Pit Lane starter in front of the 2 group of trucks on a rolling start. The release will occur when the last truck has passed the start-line or pit lane exit, whichever is later.
- 2.5.4 Any driver unable to start the Green Flag/Pace lap or start is required to indicate their situation as per Motorsport UK Regulation Q.12.11.2. In addition, any driver unable to maintain their grid position on the Green Flag Lap, to the extent that all other trucks are ahead of them, may complete the Green Flag lap but must remain at the rear of the last row of the grid but ahead of any trucks to be started with a time delay.
- 2.5.5 The driver in pole position is responsible for setting a constant pace to the start at a speed of between 50 and 70 k.p.h. All drivers should stay in grid position, at between 2 to 3 truck lengths from the truck in front and in two straight lines according to the grid sheet until the red light goes out to indicate the start, if there is a split grid then the second start will be indicated by the use of the National flag. Failure to comply with this will be deemed a false start and penalised in accordance with 4.3.5.
- 2.5.6 In the event of any starting lights failure the Starter will revert to use of the National Flag once all competitors have been advised of the fact.
- 2.5.7 The Organisers reserve the right to amend this start procedure via a bulletin issued to all competitors. This may involve changing the method of starting and/or the countdown procedure leading up to the start signal being given.

2.6 SESSION RED FLAG:

- 2.6.1 Should the need arise to stop any race or practice; red lights will be switched on at the Startline and red flags will be displayed at the Startline and at all Marshals Signalling Points around the Circuit. This may be supplemented by the showing of red lights around the circuit.

This is the signal for all drivers to cease circulating at racing speeds, to slow to a safe and reasonable pace and to return to the pit lane, during practice, and to the rear of the starting grid area, during a race, stopping before the last row of the grid unless otherwise directed by officials.
- 2.6.2 Trucks may not enter the Pits unless directed to do so or repairs are necessary. Work on trucks already in the Pits must cease when a race is stopped and may only continue under the control of a Scrutineer. Trucks in the Pits may not re-join the grid.
- 2.6.3 All Competitors who are able to take part in any restarted race may do so in accordance with Q.12.16. For the avoidance of doubt any competitor who is not running at the showing of the flag is entitled to take the restart from the pit lane on the first racing lap regardless of the distance covered within the previously started part of the race unless in breach of 3.4. The release of any pit lane starter will occur when the last truck in all classes has passed the start-line or pit lane exit, whichever is later.

2.7 PITS, PADDOCK & PITLANE SAFETY:

- 2.7.1 Pits & Paddock: Competitors must ensure that the Motorsport UK, Circuit Management and Organising Club Safety Regulations are complied with at all times. In addition, any paddock plan issued by the Organisers must be complied with and the minimum amount of space should be used when setting up.
- 2.7.3 Pit lane: The outer lane or lanes are to be kept unobstructed to allow safe passage of trucks at all times. The onus shall be on all Drivers to take all due care and respect the pit lane speed limits. No-one under the age of 16 is permitted access to the pit lane unless they are the holder of a Motorsport UK Junior Race licence
- 2.7.4 Refuelling: May only be carried out in accordance with the Motorsport UK General Regulations, the Organising Club Regulations, Circuit Management Regulations and the SRs or Final Instructions issued for each Circuit/Meeting.
- 2.7.5 Speed Limit Pit Lane Speed Limit will be 60 k.p.h.

2.8 RACE FINISHES:

After taking the Chequered Flag drivers are required to:

- a) progressively and safely slow down
- b) remain behind any competitors ahead of them,
- c) return to the Pit Lane Entrance/Paddock Entrance as instructed,
- d) comply with any directions given by Marshals or Officials,
- e) keep their helmets on and harnesses done up while on the circuit or in the pit lane,
- f) place their truck into the Parc Fermé where it must remain until released by the Championship Eligibility Scrutineer or his deputy.
- g) Attend any podium presentation that may be required.

2.9 RESULTS:

All Practice Timesheets, Grids, Race Results are to be deemed Provisional until all vehicles are released by Scrutineers after Post Practice/Race Scrutineering and/or after completion of any Judicial or Technical Procedures (Motorsport UK regulation D26.3).

2.10 TIMING MODULES:

It is the Competitors responsibility to ensure that a working transponder is fitted to the vehicle in accordance with Q.12.8.1. No electronic equipment may be placed within five metres of any official timing line and any breach of this may result in the confiscation of the equipment concerned.

2.11 QUALIFICATION RACES:

If any event is oversubscribed the Organising Club may at their discretion run Qualification Races details of which will be published in Final Instructions for the event.

2.12 OPERATION OF SAFETY CAR:

There is no provision for a Safety Car within truck races.

3. SPECIFIC CHAMPIONSHIP REGULATIONS

- 3.1. For the first season only, a completely new race team competing in the Championship will be required to pay only half of the BTRA membership fee.
- 3.2. The standard minimum scheduled distance shall be 15 minutes whenever practicable but should any race distance be reduced at the discretion of the Clerk of the Course or Stewards of the Meeting, it shall still count as a full points scoring round.
- 3.3. A driver may only race the truck in which he/she set a Qualifying time no replacement trucks are permitted.
- 3.4. Any Competitor who is not running at the time of the showing of the red flag or who receives mechanical assistance may only restarted the session or race from the pit lane, behind any truck that was running at the red flag, after all other competitors have passed the pit exit. Motorsport UK Yearbook Regulation Q.12.16 must be respected.
- 3.5. There will be one qualifying session and five race sessions allocated to each class at each meeting and there may also be a warm-up on day 2 where time permits. However, a number of formats may be used according to the level of entries received prior to each meeting.
- a) QUALIFYING:
- The qualifying will normally be one session each for classes one and two. However, if numbers do not reach the maximum grid size then one session may be cancelled with all trucks qualifying in that one session.
- b) GRID POSITIONS:
- For race 1 grid positions will be set by the times set during the qualifying session.
- For subsequent races, grid positions will be set from the result of the previous race, with all competitors in each class being reversed. E.g. the last placed finisher of Class 1 in Race 1 will start on pole in Class 1 for Race 2, and the last placed finisher of Class 2 in Race 1 will start on pole in Class 2 in Race 2.
- Non-finishers will be placed behind the last finisher of their class on the next race grid, where possible in the order they retired/stopped on track. Any non-starters will be placed after non-finishers.
- Should any competitor be subject to a grid penalty it will then be applied to adjust their position on the grid.
- Finally anyone that has been disqualified through a race penalty or didn't qualify will start from the back of their class.
- c) RACE FORMAT:
- Alternative formats may be used at the discretion of the Organisers but the format to be used will be published via a Championship or Event bulletin.
- 3.6. Race numbers and decals must be carried in accordance with Regulation 5.17. Failure to do so will result in a fine. Race number 1 is reserved for the Class 1 Champion from the preceding season should he wish to use it. If the champion does not wish to carry number 1 then number 1 will not be allocated for that season. If the champion decides to take the number 1 then his previous number will not be reallocated so that he may return to that number at some stage in the future.
- 3.7. Radio systems are permitted in accordance with Q14 as the pit signalling wall is closed during Truck Races. Any radio system used by the teams must be in accordance with Q11.3 (v) and must not interfere with any venue emergency frequencies. Ofcom licences should be available at all events as they may be checked by the Organisers.
- 3.8. All trucks must be fitted with a forward-facing camera using an SD card which is compatible with windows media player. Camera cards must be cleared at the start of each meeting. The camera fitment must be approved by the Scrutineer and all footage obtained is not for commercial use. The Clerk of the Course and the Stewards may make use of any such footage in reaching their decisions on any judicial matters.

- 3.9 All competitors must ensure that their camera is fully functional and switched on at all times while the truck is on track, e.g., from leaving the assembly area to entering Parc Fermé. Any problems with the operation of the cameras must be reported to the Clerk of the Course and/or the Eligibility Scrutineer immediately.
- 3.10 The Championship Eligibility Scrutineer or another Official nominated by him will be the only person able to collect the camera cards, including those from any additional cameras which may be fitted and logging data after each session in Parc Fermé. Teams may not view the cards or data downloaded until the Clerk of the Course has completed his investigations and the protest / appeal time has expired.
- 3.11 The Championship Organisers may nominate a specific in truck camera provider, details of which will be circulated via Championship Bulletin at such time as it is confirmed.
- 3.12 Competitors are advised to fit a rear facing camera and may fit other additional cameras at their discretion but only with the approval of the Eligibility Scrutineer. All camera footage must be made available to the Clerk of the Course and the Stewards if it is requested.
- 3.13 Once the judicial process is concluded footage from on-board cameras must be made available to the Championship TV company for their use.
- 3.14 Any truck with significant damage to the front will be shown the black & orange flag and must immediately stop in the pit lane to have the damage inspected by a scrutineer who will determine if it is safe for the truck to continue.
- 3.15 Track Limits & Driving Standards penalties will be applied in accordance with Motorsport UK Regulations sections C & Q.

4. PENALTIES

All penalties will be in accordance with Section C of the current Motorsport UK Yearbook and these Regulations.

4.1 Infringements of Technical Regulations:

4.1.1 Arising from post practice Scrutineering or Judicial Action:

Minimum Penalty: The provisions of Motorsport UK Regulations: C3.3.

4.1.2 Arising from post-race Scrutineering or Judicial Action:

Minimum Penalty: The provisions of Motorsport UK Regulations: C3.5.1 (a) and (b).

For infringements deemed to be of a more serious nature the Clerk of the Course may invoke the provisions of Regulation C3.5.1 (c). However, if the Clerk of the Course believes that there is some mitigation surrounding the infringement then C3.5.1 (c) need not be implemented.

4.2 All infringements of non-technical Motorsport UK Regulations and the Sporting Regulations will be dealt with in accordance with these Championship Regulations and the General Regulations of the Motorsport UK.

4.2.1 The only data permitted in any Judicial hearing is that which is obtained from the data downloaded by the competitor from the approved monitoring device noted in 5.18.

4.2.2 If "new" evidence is introduced at any appeal hearing then the Clerk of the Course must be called to provide an expert opinion on that evidence to the appeal panel.

4.3 Additional specific Championship penalties:

4.3.1 Maximum Road Speed - Speeding (See 5.18):

During Practice and Race, contravention of Regulation 5.18 will invoke the following:

a) During Practice: Loss of practice times and race start from back of grid.

b) During Race:

- FIRST CONTRAVENTION:

- Speeding for longer than 0.75 sec. or GPS pulses indicated (Class.1) 10 second penalty.
- Speeding for longer than 2.75 sec. or GPS pulses indicated (Class.2) 10 second penalty.
- Speeding for a period of 5 - 6 seconds 20 second penalty
- Speeding for a period of 7 - 8 seconds 30 second penalty
- Speeding for a period of 8+ seconds Disqualification.

- SECOND CONTRAVENTION:

- The second penalty will be in addition to the first but in line with those given above.

- THIRD CONTRAVENTION:

- Disqualification.

4.3.2 Any vehicle which exceeds 170 kph will be excluded from the race on the first contravention, irrespective of the duration of the contravention. The penalty for exceeding the speed in any free practice is at the discretion of the Clerk of the Course.

4.3.3 Exhaust Smoke Emissions (See 5.19):

The Organisers may appoint one or more Judges of Fact to check for excess exhaust smoke during all practices and races. Any truck adjudged by a nominated Judge of Fact or duly appointed Scrutineer, to be emitting any visible smoke at any time during an event, will immediately be shown the Black and Orange Flag, by decision of the Clerk of the Course alone.

Any truck that contravenes the smoke regulation at an event and is considered unacceptable to the organisers will in, qualifying and or races will be issued with a Yellow warning card, if the truck then in a subsequent race/qualifying shows no significant improvement a second yellow card will be issued. If the organisers, then consider that the truck is still not complying with the smoke regulations in any subsequent race/qualifying then a red card will be issued. If a red card has to be issued, then that truck will have all championship points deleted for that event and will be excluded from the rest of the event. If a competing Truck is reported for smoke and on investigation by the Championship Eligibility Scrutineer, is found to be due to a mechanical problem such as an air inlet malfunction such as a boost pipe becoming detached, the Clerk will be informed, and he may decide that the penalty will not be applied.

- 4.3.4 Failure to respect the Black and Orange flag for smoke or damage will result in exclusion from the race and this penalty will not be subject to appeal.
- 4.3.5 These decisions (4.3.2 & 4.3.3 a & b) will be judgements of fact and hence not subject to appeal. This regulation cannot be invoked as a reason for protest by competitors.
- 4.3.6 Any Competitor adjudged to have made a false start or breached any part of the start procedure will be penalised by means of a ten second penalty being added to the total race time.
- 4.3.7 Breaches of 2.7.5 will usually be dealt with by means of a fine of up to £10 per k.p.h. above the limit in qualifying and by means of a "drive through" penalty during races.
- 4.3.8 If within 14 days of an incident it appears from the video footage from the nominated TV company and/or from any other evidence, not previously presented to the Clerk of the Course and/or Stewards of the Meeting, that there may have been a breach of any non-technical regulation the Clerk of the Course can investigate the incident notwithstanding that the Clerk of the Course and/or Stewards of the Meeting may or may not have already investigated the incident.
- 4.3.9 Any Competitor may be called before the Championship Stewards who at their discretion may take further action against the Competitor. This may include, but is not limited to, the loss of Championship points, a fine to a maximum of £10,000 or disqualification from part or all of the Championship.
- 4.3.10 The Clerk of the Course may impose a "Stop / Go" or "Drive through" penalty for a breach of regulations, in accordance with Q.12.26.
- 4.3.11 Any vehicle not carrying the mandatory Championship decals will be subject to a fine of £100 for the first infringement and then £500 for any subsequent infringement.
- 4.3.12 Failure to have an operative Judicial camera will result in the Clerk of the Course applying the following penalties:
 - a) 1st Offence: Deduct one championship point.
 - b) 2nd Offence: Deduct two championship points.
 - c) 3rd Offence: Deduct three championship points.
 - d) Further Offences: Refer the competitor to the Championship Stewards for further action.

5. TECHNICAL REGULATIONS

5.1 INTRODUCTION:

The following Technical Regulations are set out in accordance with the Motorsport UK specified format and it should be clearly understood that if the following texts do not clearly specify that you can do it you should work on the principle that you cannot.

5.2 GENERAL DESCRIPTION:

5.2.1 The British Truck Championship is for Competitors participating in Racing trucks in general compliance with the technical regulations issued and applying to the 2021 F.I.A. European Truck Racing Championship, Race Trucks (with the exceptions of the items detailed in this document) or the following regulations.

The British Truck Championship is run in two Race Truck classes. Any truck in class 2 that has technical changes made to it which significantly improves its performance, such as a different engine being fitted, it shall be reassessed by the committee and may be reclassified into class 1 and any points gained prior to this time will not be carried over. If a truck enters the championship, the Championship Eligibility Scrutineer in consultation with Trucksport and the Championship Organiser will agree which class the truck will be in.

5.2.2 DEFINITION:

Two-axle road tractors with a minimum production of 50 units during any 12-month period duly certified by an official documentation from manufacture.

The general shape of the tractor must correspond to the shape of a road-going tractor homologated for the transportation of merchandise.

5.2.3 POWER-TRAIN:

This consists of a single power generating unit (engine) which feeds its power directly to a friction plate clutch. This power then passes through a mechanical gearbox and a mechanical final drive unit, which then distributes the power to the road wheels. No additions or deletions to this power train are permitted.

The engine must be derived from a unit fitted to a road-going tractor. The engine must come from the commercial range of the truck manufacturer in the year of the truck production, and not necessarily from the model of truck, and must have been produced in a minimum quantity of 100 units.

All trucks must comply with Mainland British Type Approval for the main vehicle specifications and not have a maximum engine cubic capacity of more than 14 litres for 2021. and 13 litres in 2022 as per the FIA regulations.

Note: In order to run in the FIA European Truck Racing Championship in 2021, Competitors should be aware that FIA regulations will require a 63mm. diameter (as per FIA specification) air restrictor to be fitted to the air inlet of the engine and all the air required to run the engine must pass through this restrictor.

5.2.4 TECHNICAL PASSPORT:

As part of the entry requirements for the BTRC championship, every entrant will have to complete a vehicle declaration form, for their vehicle, prior which will form the basis of a technical passport.

5.3 SAFETY REQUIREMENTS:

All Motorsport UK Section K Safety Criteria Regulations apply as relevant. For Race Trucks competing in the European Cup, regulations applicable to the 2021 FIA European Truck Racing Cup apply. For British Race Trucks not competing in the above the following regulations apply.

5.3.1 ROLL CAGE:

An internal cab roll cage must be fitted. A roll cage is as shown in diagram 8. It must be in one piece (i.e., all parts welded to each other) and follow the interior shape of the cab as closely as possible and be free from unevenness or cracks. The following members are mandatory, two rear diagonals, two roof diagonal members and one member joining the centre section of the front top cross member to the lower rear cross member or lower part of the rear vertical leg of the main roll cage. At least two members joining the rear and front vertical legs, one at the height of the drivers and passengers' pelvis / legs to protect both from side impacts. the second member must be as close as possible to the foot of each vertical leg, cab floor permitting.

Two additional members, one on each side, joining the top horizontal member to the vertical rear member of the roll cage, this is to provide protection for drivers head and strengthen the corner of the roll cage.

If the driver's brake, clutch, and accelerator pedals are positioned in front of the front wheel centre line an additional cross member must join the front outer foot of the internal roll cage to the cabin pivot point. The cabin pivot point and or the original cabin stiffening rail may be incorporated into this member.

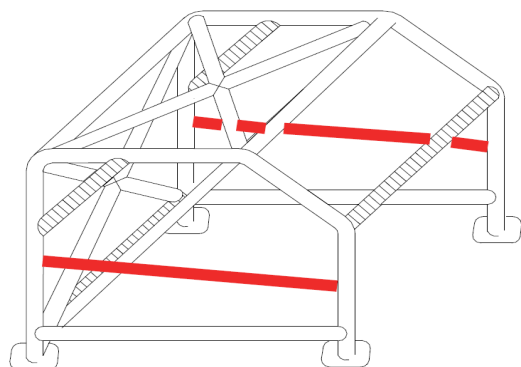

The material specification must comply with the one detailed below for the roll cage and must have a minimum diameter or side length, of 25mm.

Note: It is permissible, and even recommended, to fit additional struts to the cage.

The cabin pivot point and / or the original cabin stiffening rail may be incorporated into this member. The material specification must comply with the one detailed below for the roll cage and must have a minimum diameter or side length of 25mm.

The minimum fixation of the cage to the cab consists of four mounting plates, one for each vertical pillar of the cage.

Each mounting foot must have an area of at least 200 sq. cm and a thickness of 3mm. Reinforcing plates with an area of at least 200 sq. cm and a minimum thickness of 3mm must be fitted such that the cab floor is sandwiched between the mounting feet and the reinforcing plates. At least three bolts must clamp each mounting foot to its reinforcing plate, such bolts to have a minimum specification of 8.8 (S grade) and diameter of 12mm. This mounting represents a minimum.

- 5.3.2 The safety cage described in 5.3.1 must be connected, with steel sections to the chassis in a minimum of 4 separate locations. The additional supports are required from the four main roll vertical pillars via the reinforcing plates under the cab, at least 3 of these supports must be connected directly with steel section to the specification as the roll cage detailed below. The fourth connection must comply with the same material specification as below for the roll cage and will have a minimum diameter or side section of 25mm.

NOTE: Two connections must be in front of the driver's feet and the two rearward of the rearmost position of the driver.

It is permitted to increase the number of bolts and to attach the roll cage to the cab shell (e.g., to screen and door pillars).

Minimum material specification for all mandatory tubes in cold drawn seamless steel tube with a minimum tensile strength of 340 N/mm². The minimum permitted tube sizes are either: 57.0 mm outside diameter and 4.9mm minimum wall thickness or 63.5 mm outside diameter and 3.2mm minimum wall thickness or 70.0 mm outside diameter and 2.4mm minimum wall thickness. It is permitted to use a combination of these permitted tube sizes. All mandatory tubes must have an inspection hole of 5 mm diameter, drilled in an easily visible position. All welding should be of the highest quality possible, with full penetration (preferably) arc welding and in particular Heliarc). These requirements are a minimum. Alternatively, the roll cage must comply with the 2021 FIA European Truck Racing Cup Regulations.

5.3.3 SIDE GUARDS:

Metal side guards must be fitted between the mudguards of front and driven axles to prevent wheels interlocking. The sideguards may be made with either: One steel tube 65mm diameter x 3mm wall thickness or Two steel tubes 50mm diameter x 3mm wall thickness. This must be good quality steel tube. This side guard must be fixed directly to chassis members, not via a sub-frame.

Aluminium may NOT be used in place of steel.

Outriggers from the chassis to the sideguards must be made from material at least equal in strength to the sideguard material. All tubes must have a 5mm hole drilled in a visible position for inspection purposes.

Maximum spacing between any two outriggers is 1.5 metres Maximum unsupported sideguard overhang is 500mm.

Maximum permitted gap (inside view) between front or rear mudguard and the sideguard is 100mm.

It is strongly recommended to cover the side guards with fairings, but all such fairings must be readily detachable to allow for inspection of the side guards.

5.3.4 OUTRIGGERS:

Outriggers must be mounted to the chassis using spreader plates of at least 100 sq. cm. area and 5mm thickness. These plates must be welded to the outriggers and bolted to the chassis. At least 4 x 8mm diameter bolts must be used for each outrigger, these bolts must be at least grade 8.8 (S grade). It is only permitted to drill the chassis for the attachment of sideguards. The bottom of the sideguards must be at least 500mm from the ground. The top must be no more than 1 metre from the ground. A sideguard must extend outwards so that they are within 300mm of the extremities of the vehicle in plan view, but they may not project beyond the extremities of the vehicle in plan view. All welding must be of the highest quality with full penetration. It must be possible to inspect all welds. Sideguards must not present any sharp angles or corners in plan view. It is permitted to cover the sideguards with fairings as described in section 5(6), but all such fairings must be readily detachable to allow for inspection of sideguards by scrutineers.

5.3.5 FRONT AND REAR GUARDS:

Guards must be fitted to front and rear of the vehicle to prevent it from driving over the top of "armco" safety barriers, and to assist with "suspended tow" vehicle recovery. These guards must meet the following requirements with regard to general dimensions:

These guards must consist of two horizontal steel tubes. The minimum permitted tube sizes are:

57.0mm outside diameter and 4.9mm minimum wall thickness, or

63.5mm outside diameter and 3.2mm minimum wall thickness

An alternative equivalent can only be used with the written permission of the Championship Eligibility Scrutineer.

The ends of all tubes must not be left exposed. Bottom tubes must be joined to top tubes/bumper and there must be no sharp corners, exposed corners, or angles with unacceptable radius at the corners. The guard must only be manufactured of the specified tube, any reinforcing can only be allowed at the rear of the guard. The fixing of additional support to the guard in front of the vertical centre line of the guard tubing is strictly forbidden and the Eligibility Scrutineer must pass the guard as fit for purpose prior to the event. Note that this includes the fixing brackets for the plastic bumpers which also must be behind the front guard tube centre line.

The requirements for these guards are as follows:

FRONT GUARD: The front face of the guard must be vertical and in line with the front face of the standard bumper. The top face of the guard must be in line with the top face of the standard bumper. The front guard must be attached directly to the chassis main members, as described in 5.5.1.2. and all the attachments must be forward of the front wheels.

These guards must have a radius on ends on main guards and fixing for any trim such as plastic bumpers must be located behind the inside radius of the guard tube. In the event of the bumper or trim being detached, no sharp edges will be left behind.

REAR GUARD: The rear face of the guard must be vertical. No part of the rear guard may extend more than 200mm behind the end of the chassis main members. The top face of the guard must be level with the top of the main chassis rails and the end configuration must have a radius. The top face of the guard must not be above the top flange of the chassis main members, measured at the extreme rear of the vehicle. Overall width of the guard must be between 1800mm and 2300mm. The guard must be covered by a plastic bumper securely attached. The rear guard must be attached directly to the chassis main members, as described in 5.5.1.2. and all the attachments must be behind the rear wheels.

It is highly recommended that the rear guards be braced from the main chassis to the overhanging part of the rear guard behind rear wheels.

FRONT AND REAR GUARDS: The bottom face of each guard must be between 300mm and 400mm above the ground and must be between 2000mm and 2300mm wide. All exposed parts of the guards which are not part of the standard bumper(s) must be made of tube. Tube material is free, but it is recommended that roll cage or sideguard tube is used. The ends of any tubes must not be left exposed. Bottom tubes must be joined to top tubes/bumper(s) and there must be no sharp edges, corners or angles exposed. It is permitted to cover all or part of the guards with securely attached metal panels. Each guard must be able to withstand a load equal to the vehicle weight on the rear axle, applied horizontally to the bottom tube, along the axis of the vehicle. It must also be capable of supporting the weight of its own end of the vehicle. These loads must not cause distortion of the guard. Note: The load requirements can be checked by positioning the vehicle with the guard against a wall engaging a gear and applying load until the driven wheels spin on a dry road; and jacking up the appropriate end of the vehicle on the guard. with the load spread over the centre metre of the bottom tube.

Note that both Front and Rear Guards must have a reasonable radius on all corners of the guard, as state above with no shape edges.

5.3.6 SEAT BELTS:

All seat belts must be a set of unmodified proprietary manufactured in compliance with FIA 8853/98 or 8853/2016 FIA standards is compulsory (TL 24 and TL57). with a six-point fixing and must be securely attached to the vehicle's cab structure or roll cage (Motorsport UK Regulation Q13.10.2 applies). Anchorage points on the cab structure must be reinforced to ensure adequate strength. Belts must have 2 parallel shoulder straps and one abdominal strap and two straps between the legs. Fixation points to be 2 for the abdominal strap and 2 behind the drivers' seat for shoulder straps and either one or two points for straps between the legs.

The shoulder straps must be fixed on a rear transversal tube welded to the roll bar or attached to the upper anchorage points of the front belts.

The transversal reinforcement shall be a tube measuring at least 38 mm x 2.5 mm or 40 mm x 2 mm, made from cold drawn seamless carbon steel, with a minimum yield strength of 350 N/mm².

The straps may be attached by looping or by screws, but in the latter case an insert must be welded for each mounting point (see Drawings 253-17C and 253-53 for the dimensions).

These inserts will be positioned in the reinforcement tube and the straps will be attached to them using bolts of M12 8.8 or 7/16UNF specification. The angle of the shoulder straps at the rear of the seat must be at a maximum of 20 degrees to the horizontal.

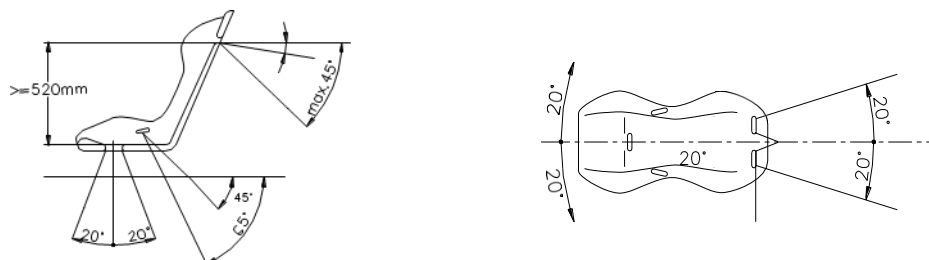

5.3.7 Fire Extinguishers in compliance with FIA Appendix J and 2021 FIA. European Truck Racing Cup regulations must be fitted. Date extinguisher must be checked, which must be no more than two years after the date of filling or the date of the last service.

Permitted Extinguishants:

AFFF, FX G-TEC, Viro3, powder or any other extinguishant homologated by the FIA (TL n°6 of the Appendix J).

Minimum quantity of extinguishant

- | | |
|--------------|------------|
| a) AFFF: | 2.4 litres |
| b) FX G-TEC: | 2.0 kg |
| c) Viro3: | 2.0 kg |
| d) Zero 360: | 2.0 kg |
| e) Poudre: | 2.0 kg |
| f) Novec | 2.0 kg |

5.3.7.1 Fixations:

All extinguishers must be adequately protected and must be situated within the survival cell. In all cases their mountings must be able to withstand a deceleration of 25 g. Furthermore, only quick-release metal fastenings, with metal straps, are accepted. Anti-torpedo tabs are required.

5.3.7.2 Automatic Systems:

In addition, to the system described above, it is recommended to fit an automatic extinguishing system complying with Article 253-7 of Appendix J.

5.3.8 CIRCUIT BREAKER - ENGINE SHUTDOWN:

A circuit breaker or isolator switch which shuts down the engine and disconnects the batteries from all electrical circuitry (except any automatic fire extinguisher system) must be fitted behind the fifth wheel and between the chassis rails. This switch must be painted yellow and identified by a red spark on a white edged, blue triangle. The main earth between batteries and the chassis, or the negative lead in the case of insulated return wired vehicles must be coloured yellow or covered with yellow material. In the case of vehicles which use a mechanical shutdown system, a shutdown device must be fitted which is separate from the electric circuit breaker.

The device must be fitted close to the circuit breaker, be clearly marked, and have clear operating instructions (e.g., "pull knob to stop engine"). An engine shutdown switch and or mechanical device must be fitted in the cab, with positive on-off positions clearly marked. They must be operable by the driver, normally seated and wearing a seat belt. The switch must also isolate any electric fuel pumps.

It is recommended that either an air intake shutdown valve, exhaust shutdown valve or a shut off valve in the oil feed line to the turbocharger be fitted to restrict engine revs in the event of engine runaway. These devices must be operable from both inside and outside the cab.

5.3.9 DRIVERS AND PASSENGERS WINDOWS:

For safety reasons, whatever the external weather conditions, a protective net in a readily visible contrasting colour must be fitted to the inside of both the drivers and passenger's door covering the area of the window. It must not impede vision but must be able to prevent the driver's hand or arm from falling out of the window in the event of a vehicle roll over. This net must be approved by the Eligibility Scrutineer for the championship.

5.3.10 PROP SHAFT:

A minimum of 50% of the propeller shaft length must be covered all around its circumference by a steel material with a minimum thickness of 6mm, so as to prevent it hitting the ground in case of breakage. This cover may be split along its length and can be joined together by means of at least 6 off M10 bolts to have a minimum specification of 8.8 (S grade).

It must have 4 fixing points (2 bolted to main chassis rails and 2 bolted to the authorised under frame) which would not be counted as a transversal member. The 4 off bolts used to fix this cover must be a minimum of M10 bolts to have a minimum specification of 8.8 (S grade).

The prop shaft must not pass through any fuel, water, or air tanks.

5.3.11 Wheel Nut Covers may only be used if recessed wheel nuts for front wheels are not available and only with the express permission of the Eligibility Scrutineer.

5.3.12 Fireproof Bulkhead All vehicles must have a protective bulkhead of non-inflammable material between the engine/transmission and the driver's compartment capable of preventing the passage of fluid or flame in the case of fire. Gaps must be sealed with GRP or an RTV sealant. Use of magnesium is prohibited.

5.3.13 FUEL / OIL LINES:

It is prohibited to run any fuel, oil, or water lines within the cab. The only oil lines which may run within the cab are those leading solely to temperature or pressure gauges. Such lines must be metallic or aircraft quality. The clutch fluid reservoir may be positioned in the cab but must be securely fitted and covered with adequate protection as determined by the Eligibility Scrutineer.

5.3.14 STEERING LOCK AND QUICK RELEASE MECHANISM:

Any steering lock system fitted to the vehicle must be removed. If the steering column passes in between the driver's legs, it must be covered with protective detachable foam in order to prevent injuries to the driver's knees. The steering wheel must be fitted with a quick release mechanism. It must consist of a flange concentric to the steering wheel axis, coloured yellow through adonisation or any other durable yellow coating and installed on the steering column behind the steering wheel. The release must be operated by pulling the flange along the steering wheel axis.

5.3.15 PARK BRAKE:

The location of the park brake control must be clearly indicated by a notice inside the cab at least 20cm wide. The park brake control must be operable by the driver normally seated with seat belts fastened. The parking brake control must not protrude inside the free opening of the roll bar "door" to prevent or hinder extraction of the driver.

5.3.16 ENGINE OIL CATCH TANK:

All engine breathers venting to the atmosphere must lead into a catch tank arranged in such a way as to prevent oil from spilling onto the track. If a single catch tank is used, it must have a volume of at least 4 litres. It is permitted to use multiple tanks; each tank must be at least 2 litres. Tanks may be of any material, but it must be possible to view the contents of the tank (e.g. a sight glass is required in a metal tank, plastic tanks must be translucent). All tanks must be capable of being readily emptied. The tanks must be oil resistant, material and securely fastened.

5.3.17 LOWER CAB ACCESS STRIPS:

Must be modified, if necessary, so as to minimise the possibility of such components puncturing tyres in an incident.

5.3.18 SEATS:

The driver's seat must be homologated to a current FIA standard with an extension with energy absorbing and non-inflammable material around the driver's head and must not be modified. Seats in compliance with 8855-1999 FIA standard.

If there is a cushion between the homologated seat and the occupant, the maximum thickness of this cushion is 50 mm.

Seats in compliance with 8862-2009 FIA standard.

If a foam insert is used between the homologated seat and the driver, minimum lateral support to the driver's head, shoulders and pelvis must be guaranteed as follows:

- a) 230mm min. at seat-side-head support along the head-plane.
- b) 180mm min. at seat-side-shoulder support along the shoulder-plane.
- c) 100mm min. in height at seat-side-pelvis support along the pelvis-plane over a length of 200mm min.

All seats must be firmly attached and must not slide, tilt, hinge, or fold. The driver's seat must support the driver and hold him in position inside the cab.

All seats must face forward. Passenger seats may be removed. All joints between any seat and the cab (i.e., seat to sub-frame [if fitted] and sub frame to floor) must have at least 4 x 8 mm diameter or 6 x 6 mm diameter bolts, minimum grade 8.8 ("S" grade). Reinforcing steel plates of min. size 30x30mm at least 10 mm thickness must be fixed under the floor of the cab and the fixing bolts must pass through the centre of these plates. It is permissible to weld a mounting, for the seat to fix to, into the main cab structure but this must be approved by the eligibility Scrutineer.

Sliding seat runners must be locked and bolted into position by a system requiring the use of tools.

5.3.19 WATER TANKS:

No water tank may be situated within the chassis rails between the wheelbase and should be mounted to the main chassis where possible.

5.4 GENERAL TECHNICAL REQUIREMENTS:

- 5.4.1 Vehicle competing in all classes must comply in all respects with the exception of the air inlet restrictor requirement, to the technical regulations issued as being applicable to the 2021 FIA European Truck Racing Championship, including all and any bulletins which may be issued during the course of the year, modifying, or supplementing these regulations.
- 5.4.2 Vehicles competing in British Race Truck Class must comply with the following regulations 5(4).3 to 5(6) inclusive and 5(5) to 5(18) inclusive.
- 5.4.3 Vehicles competing in Class 2 must comply with the following points at all times:
 - 5.4.3.1 The truck chassis / cab must be at least three years old at the start of the season.
 - 5.4.3.2 Shock Absorbers are to be of the single adjustment (soft/hard) type only. Two way adjustable (bump and rebound) and three way adjustable (high speed bump, low speed bump and rebound) are not allowed.
 - 5.4.3.3 Maximum castor 20 angle on front axle wheels degrees
 - 5.4.3.4 No works/factory prepared/tuned dedicated racing engine or E.C.U. to be allowed in Class 2 that is not readily available to be purchased on the open market and have not been built by manufacture for racing purposes only. Any engine used must have been in series production 5 years prior to the start of the championship year which the engine is to be used in.

PROHIBITED ENGINES:

The Following Race Prepared Engines to FIA Participation Standard in the last 5 years are excluded from Class 2.

- a) MAN D26
- b) Iveco Cursor 13
- c) Buggyra /CAT C13

NB In addition the older D28 Man Race Engine that is no longer in production is now eligible to be used in Class 2. Also, the older Iveco Cursor 13 not fitted with common rail fuel injection system and built before 2010 are eligible.

- 5.4.3.5 No mechanical governed fuel injected engines would be allowed to enter the championship; only electronic fuel injected engines will be allowed to run in championship.
- 5.4.3.6 Rear Axle: This must be from a road going 18t rigid truck or 38t artic with a minimum operation rated at 11.5t with a minimum rating of 11.5 tonnes for the rear.
- 5.4.3.7 Tyres: Class 2 trucks will be limited to 2 additional new tyres per event with the exception of the round at Thruxton where 4 new tyres will be allowed.
- 5.4.3.8 Trucks which have previously competed/raced in the FIA truck racing championship, in the last two years cannot race in class2 even if they comply with the class 2 regulations. The final decision as to which class a truck can be entered is the decision of the Championship Organiser and the Eligibility Scrutineer in consultation with Trucksport.

5.4.4 DEFINITIONS:

Race truck must be derived from two-axle road tractors with a minimum production of 50 units of this type (Cabin & Chassis) during any 12-month period duly certified by an official documentation from manufacture.

The general shape of the tractor must correspond to the shape of a road-going tractor homologated for the transportation of merchandise, with a minimum Gross Vehicle Weight of 18 tonnes.

The engine must be derived from a unit fitted to a road-going tractor.

The following mechanical components must be from a road-going tractor unit homologated for the transportation of merchandise: - Gearbox - Front and rear axles - Steering box - Components of the braking system.

The front axle assembly cannot be driven.

The axles which must be solid beam construction must be from road-going tractors homologated for the transportation of merchandise with a minimum axle load of 6.7 tonnes for the front and 11.5 tonnes for the rear. The definitions given in Article 251 Appendix J of the 2020 FIA and shall apply to these regulations, which shall take precedence over the Terminology section of the Motorsport UK Regulations, as published in the current Motorsport UK Yearbook. Nevertheless, the Section B of the Motorsport UK Regulations shall apply in all instances where it covers a topic not covered by art. 251 Appendix J of the FIA regulations.

- 5.4.5 Pattern Parts unless specifically prohibited by these regulations it is permitted to use "pattern parts" as direct replacement of manufacturer's parts, provided such parts are commercially available as direct replacements and of the same design as the vehicle manufacturer's parts.

5.4.6 REPAIRS:

Repair of components may be affected using accepted repair methods such as welding, and any repair must be fit for purpose. Competitors attention is drawn to the limitations of such action, the addition of gussets, additional welding or material, the change of shape, design, material, surface finish or removal of material constitute a "modification".

5.4.7 Standard Specification Any reference to standard specification and/or parts and/or materials in these regulations shall be interpreted as a reference to the manufacturer's listed standard item(s) only as set down in the appropriate type approval. It shall not include manufacturer's options.

5.4.8 AERODYNAMIC EFFECT:

No mechanical part must be designed to generate an aerodynamic effect.

5.4.9 CLOSE LOOP CONTROL SYSTEMS:

Apart from the engine management systems, close loop control systems are prohibited.

5.5 CHASSIS:

5.5.1 CHASSIS MODIFICATIONS PERMITTED:

5.5.1.1 It is permitted to locally modify the chassis frame in order to comply with the safety requirements specified within these regulations, in order to fit authorised reinforcements described in section 5.5.1.2. With the exception of the front and rear guards, (section 5.3.5.) all modifications must remain between the chassis rails and between the front of the complete front wheels and the rear of the complete rear wheels. Engine and transmission supports must be fixed directly to the chassis rails or to a transversal reinforcement that must be fixed within the chassis rails and retain the original principle. The chassis frame must be made of a ferrous material and must consist of two chassis rails in which have a "U" shape section.

It is not permitted to weld anything whatsoever to these members, and they may only be pierced so that various parts, as well as reinforcements and supports described in 5.5.1.2. may be affixed.

5.5.1.2 Local Reinforcements of the Main Members:

The two chassis rails may be reinforced locally with reinforcements of the same type (material & section shape) positioned inside the "U" shape. The total combined length of these must not be more than 1,000mm per main member. These reinforcements may be joined together by transversal members with a constant section that must always be less than those of the main members measured at the location of the reinforcement.

Transversal reinforcement:

Any transversal link crossing a plane parallel to the vehicle's centre line linking both main chassis rails by means of welding, screwing, riveting and/or bonding.

Transversal members:

Chassis rails may be joined together by transversal members with a constant section the dimensions of which must not exceed the height of the main members measured at the location of the reinforcement.

The fixing plate to which the additional reinforcement is attached must be square in shape and must not exceed the height of the chassis rail at the fixing point. The fixing nuts must be bolted directly to the cross member.

A maximum of 16 transverse members may be used, excluding for radiator, engine, and gearbox mountings.

These transversal members will be counted from the front end to the rear end of the chassis.

The fuel tank fixing will be counted as a minimum of 2 transversal members depending on the fixing arrangement.

Engine, transmission and fifth wheel supports will also be counted as a minimum of 1 transversal member each.

No transversal member situated within the wheelbase may protrude beyond the upper surface of the main members of the chassis frame.

Additional reinforcements:

A maximum of 5 plates per chassis rails may be used to connect the transversal members that join with the longitudinal members.

The length and width of each of the fixing plates of the underframe must not exceed the maximum height of the main chassis rails at any point. Each fixing plate may use a maximum of 6 bolts of a diameter no greater than 14 mm.

It is not permissible to mount either suspension component or side guards to the underframe/sub frame.

The fixation points must be situated within the wheelbase, between the front of the front wheel and the rear of the rear wheel.

The longitudinal reinforcements joining the transversal members must be connected to the 5 fixing plates mentioned above.

The number of longitudinal reinforcements when the truck is viewed from the side must not exceed 18.

All these reinforcements must be situated below the chassis rails and must have a maximum circumference of 280 mm.

A "U" or "L" section will be assumed equivalent to a complete rectangle for this measurement.

Each of these plates may not exceed 66,000mm² in size and may use a maximum of 6 bolts of a diameter no greater than 14mm. The two main members may be joined together with steel plates of 8mm maximum thickness fitted on their upper surface. A maximum of 8 bolts are authorised for affixing these plates to the main members. The holes through which these bolts pass through must have a diameter of no more than 6mm and must be situated at least 150mm from one another.

- 5.5.1.3 Additional support for equipment but not suspension components, are authorised. They must be bolted to the chassis rails through no more than 2 plates with a maximum length of 250mm each. The distance between these plates must be greater than 300mm. Additional supports for equipment can be fixed to the sub-frame.

Any water tanks must be securely attached to the chassis and / or sub-frame. Tanks secured to the chassis and / or sub-frame with straps which must have a minimum of two mounting points each with a minimum dimension of 20mm along the length of the tank and 100mm in the circumferential direction. Extra tanks must use mounts direct to the chassis and / or sub-frame or use a commercial spacer mounted to the adjacent tank.

No water tank may be situated between the two main chassis rails between the wheelbases. All fairings must be fixed onto the truck for initial scrutineering and throughout the event unless approved by the Eligibility Scrutineer.

5.5.1.4 Ballast Attachment Plate:

Ballast is free, but must be securely fastened by means of tools, to the chassis and / or underframe within the wheelbase. Flat plates measuring no more than 500 mm in length, 60 mm wide and 6 mm thick, may be securely fastened and / or welded to the sub-frame with the sole purpose of attaching the ballast.

The number and location of the ballast must be declared to the championship eligibility scrutineer.

5.5.1.5 Towing:

All vehicles to be fitted with front and rear towing attachments of strength and size adequate for towing the vehicle on tarmac. The rear towing attachment must be a proprietary type designed for towing an H.G.V. and be attached to the rear chassis cross rail by means of 4 correctly sized and graded bolts. The towing attachments must be painted in a contrasting colour (red, yellow, or orange) for easy identification and be available for immediate use when required. They must not project out beyond the front face of the bumpers. The standard bumper may be modified to enable fitment of towing eyes in such a manner as to not cause a hazard, but for no other purpose.

5.5.1.6 Semi-Coupling (Fifth Wheel See Drawing 6.4.7):

Regardless of manufacturer's specification, the semi-trailer pin coupling (fifth wheel) must be situated forward of the drive axle centreline.

The fifth wheel must comply with the dimensions of drawing 6.5.7. and have a thickness of 30mm.

The material is free, but the fifth wheel must have a minimum weight of 5 kg.

The fifth wheel must be situated between 1000mm and 1300mm from the ground at all times and this measurement will be taken with the fifth wheel in the horizontal position. No other part, within a circle of 2040mm radius, the centre being the kingpin axis of the fifth wheel, may be situated above the upper surface of the fifth wheel.

5.5.2 CHASSIS MODIFICATIONS PROHIBITED:

The chassis frame must be exactly to manufacturer's standard specification, excluding semi-trailer coupling (fifth wheel) but the fifth wheel must be mounting in accordance with a standard commercial fifth wheel. Excepting for any obstructions arising from the presence of either the fuel tank and/or any safety cage external bracing members or reinforcements detailed in these regulations.

The chassis frame must consist of two members forming a "U" section of the dimensions shown in 6.4.5.

5.5.3 WHEEL TRACK:

The combination of axles, wheels and tyres fitted must not increase the front or rear track by more than 150mm beyond the vehicle manufacturer's standard specification. Wheel spacers are allowed but must not have a larger diameter than the supporting face of the wheel rim. The spacers must be made of a metallic material.

5.6 BODYWORK:

5.6.1 MODIFICATIONS PERMITTED:

5.6.1.1 General it is permitted to make modifications under the general restriction that the appearance of the vehicle bears a close resemblance to the standard vehicle, including radiator grill and other trim. The cab must retain its strength and integrity and the material of the external surfaces including the floor and the doors must be of original cab material. Roof vent for cab ventilation is permitted. Air extractors at the rear of the cab are allowed but they must not project more than 50mm to the rear.

Some modification of the shape of the inner structure of the doors is allowed. The width of the cab must not be less than 1800 mm not including door mirrors. The lowest point of the floor of the cab must be at least 1000 mm above the ground.

Roof vents for cabin ventilation are permitted.

Air extractors at the rear of the cab are permitted providing that they do not more than 50 mm at the rear of the cab.

Rear view door mirrors must be fitted to each side of the truck with a minimum reflect surface area of 150cm² in order to give an effective view to the rear. It is highly recommended that a review camera be fitted.

Any corrosion or lightening of the cab structure or mountings will cause the vehicle to be rejected at scrutineering.

Vehicles with tilt cabs must have an additional device which bridges the normal tilt lock mechanism and will prevent cab tilt in the event of that mechanism disengaging. The weakest part of that device will be either one steel bolt or pin of at least 16mm diameter or two steel bolts or pins of at least 12mm diameter.

No modification of front bodywork may involve a difference of no more than 10cms on every point of front face of original truck in longitudinal axis. When viewed from above no radius may be smaller than 20cms.

5.6.1.2 Interior:

Truck carpet and floor coverings may be removed. Any loose floor coverings must be removed. Dashboards may be deleted or modified as long as this does not cause any modification to the structure of the cab. It is strongly recommended a non-standard wheel of proprietary manufacture be fitted. It is recommended that a soft rim type is used. The driver's seat, and the fitting of a passenger seat are free but must be forward facing and passenger seats may be removed. The driver's seat must support the driver and hold him in position inside the cab. All seats fitted must be rigidly located and must not slide, tilt, hinge, or fold. All joints between any seat and the cab must have at least 4 x 8mm diameter or 6 x 6mm diameter bolts, minimum grade 8.8. It is not permitted to have sliding seat runners operational on any seat. A head restraint must be fitted, capable of restraining a 17kg mass under a rearward acceleration of 5g. Its dimensions must be such that the driver's head is restrained and cannot move past it under rearward acceleration or be trapped between the head restraint and the roll cage.

5.6.1.3 Exterior for Exterior Dimensions See Drawing No. 6.4.3 Side and top fairings may be fitted, but they must be firmly affixed and made of a rigid material. No fairing may impede access to safety items e.g., fuel and electrical cut-off switches. Top fairings must be available to support the weight of a person walking on them. No fairing may extend forward of the front axle mudguard, or rearward of the end of the chassis rails. No wheel/tyre may be obscured by a side fairing. The maximum height of any fairing must not be more than 100mm above the highest face of the chassis rails behind the cab and must not impede connection of a semi-trailer. Fairings may not extend beyond the un-faired vehicle outline in plan view and all fairings must be fitted at the start of each meeting. This includes front guard fairings and removal will only be allowed due to race damage. Rear axle mudguards may be integral with fairings.

No water tank may be situated between the two main chassis rails between the wheelbases. All fairings must be fixed on the truck for the initial scrutineering and throughout the event unless approved by the scrutineer.

Only two side deflectors on rear of cab are allowed. They must not extend rearwards more than 80cms from the rear of both cab doors and a return of 10cms per side inwards at the rear of the deflector (in plan view) – maximum height – no more than the top of the cab. Under-body fairings are prohibited.

Mudguards must be fitted to all wheels and present no sharp edges and cover the full width of the tyre around a continuous arc of 120 degrees. This minimum coverage must be achieved with a continuous surface of a rigid material uninterrupted by any gaps, holes, slots, or vents. The mudguards/wing/fairing must extend forward of the relevant axle centreline. The trailing edge of the rear mudguards must be fitted with a mud flap which shall extend at least 4 cm outside both rear tyres and measuring no less than 200 mm from the ground. Standard or optional aerodynamic devices listed by the manufacture may be removed. They may be fitted only if they do not contravene the requirements of these regulations.

WINDSCREEN AND WINDOWS:

A windscreen of laminated glass must be fitted, bearing a mark to verify the fact. A transparent and unobstructed area of minimum 350mm in height covering the entire width of the windscreen must be located directly opposite the drivers' eyes. For safety reasons it is mandatory for the windscreen to be backed by two bars to prevent the screen from collapsing into the cabin in the event of an accident. Each bar must be vertical and must be made of metal with a minimum section of 45mm². The minimum distance between the two bars is 500mm. If a laminated windscreen is not available for a truck a suitable approved plastic screen could be used with the written permission of the Championship Eligibility scrutineer.

All side windows must be of a transparent polycarbonate plastic of at least 3.8mm thickness. It is allowed to remove the side window, provided that the complete window area is replaced by a proper window net in compliance with FIA article 290 2.12.4. Not all side window installations must be approved by the Championship Eligibility Scrutineer.

Rear windows: if the cab is equipped with a rear window, it must be replaced with a cover of the same material as the truck's cab.

Note tinted/silvered glass or film is not permitted on side windows, tinted glass is permitted on the rear window, provided that it is possible for a person situated 5 metres from the truck to see the driver as well as the contents of the cab, if this window is of glass construction a plastic transparent film must be fitted to the glass.

The use of protective nets is mandatory and must be in compliance with FIA article 290 2.12.4. These nets must have the following characteristics:

- a) Minimum width of the strips 19 mm
- b) Minimum size of the meshes 25 x 25 mm.
- c) Maximum size of the meshes 60 x 60 mm.

The anchor points must be as resistant as possible.

Installation: The woven strips must be non-flammable and sewn together at each point of crossing and must be attached to the safety cage or to a fixed part of the shell and covering the opening of the window to the steering wheel centre. Anchor points must be as strong as possible.

A quick release system is mandatory and must work even if the truck turns over. It must be possible to detach the net with one hand only. The handle or lever must have coloured markings ("dayglo" orange).

This net must be mounted in order to reduce the possibility of the arm of the driver from protruding out of the truck during a crash when the vehicle has lost the door or window has been broken and reduce the possibility of an external object from impacting the driver from the side of the truck.

The use of a protective net on the side opposed to the driver is mandatory when carrying a passenger.

The protective net must be mounted in order to reduce the possibility of the arm of the passenger from protruding out of the truck during a crash when the vehicle has lost its door, or its window has been broken and to reduce the possibility of an external object from impacting the passenger or driver from the side of the truck.

It must not impede vision but must be able to prevent the driver's arms from falling out of the windows if the vehicle rolls over. The Eligibility Scrutineer must approve all protective nets.

If the truck was not originally fitted with a rear window, it is permitted to fit one with a maximum area of 150,000 mm.

Windscreen wipers and washers must be fitted and maintained in working condition at all times. Two external rear view mirrors with a minimum reflective surface of 100mm x 150mm must be fitted, on each side of the truck in order to give an efficient view, to the driver, to the rear. Trailer Susie pipes and electrics must be removed.

5.6.1.4 Silhouette:

The only modifications permitted are those which do not infringe the above regulations 5.6.1.3.

5.6.1.5 Ground Clearance:

The minimum ground clearance is 190mm at all times throughout competition except for the front and side bodywork fairings which have a minimum ground clearance of 100 mm. The ground clearance of 190mm must be such that the minimum chassis height of 800mm to the top of the chassis rail from the ground is maintained. The side, rear guards and front bumper must respect the 190mm minimum ground clearance, except for the housing of the rear axle where the minimum ground clearance must be 170 mm. The minimum ground clearance is measured with the driver on-board wearing his complete racing apparel. See page 9 drawing 6.4.3

5.6.2 MODIFICATIONS PROHIBITED:

The only modifications permitted are those detailed in 5.6.1.

5.7 ENGINE:

5.7.1 MODIFICATIONS PERMITTED:

5.7.1.1 The engine and its ancillaries may only be modified within the limitations of the following regulations. It is permitted, unless specifically disallowed by these regulations for internal engine components to be substituted by alternative components sourced from the same engine manufacturer.

It is permitted to fix the engine support to the sub-frame but only in the case that the standard mounting points are below the centre of the crankshaft and with the approval of the Eligibility Scrutineer.

5.7.1.2 Camshaft timing and profile may be modified but valve lift must remain as standard.

5.7.2 MODIFICATIONS PROHIBITED:

5.7.2.1 Unless specifically permitted by these regulations the engine and all, ancillaries must be exactly to manufacturer's standard specification. Any mechanical pressure gauges used to monitor fuel delivery pressure must be isolated when the truck is racing.

5.7.2.2 It is not permitted to substitute the engine block and cylinder head castings from those which are the manufacturer's standard for the specified engine.

5.7.3 Engine Location is free

5.7.4 OIL/WATER COOLING:

5.7.4.1 It is prohibited to run either oil or coolant pipes inside the cab.

5.7.4.2 Lubrication oil sumps may be baffled internally, but the standard sump casing can be decreased in height for the sole purpose of lowering the entire engine. Oil coolers may be fitted within the periphery of the bodywork.

5.7.4.3 Water radiators may be enlarged, replaced by alternative specification items, or supplemented by additional radiators provided all radiators are fitted within the periphery of the bodywork.

Water spraying on the radiators is authorised, but only plain water may be used with no additives.

5.7.5 INDUCTION SYSTEMS:

5.7.5.1 Air induction system components up to the turbocharger or supercharger, may be modified or replaced. No part of the air induction system may project more than 200mm beyond the side or top extremities of the cab.

The total cross-sectional area of the air induction pipes, or ram air collector boxes must not exceed 1000 sq. cm

If the engine air inlet entry is situated where it is subjected to water spray allowed for intercooler, this intake must be isolated from this water spray.

5.7.5.2 It is permitted to change the type of turbocharger(s) provided that the induction system components (i.e., the pipework and fittings between the turbocharger(s) and engine(s) are standard components manufactured by the relevant engine manufacturer. It is permitted to fit only an air to air inter cooler. Water spraying on the inter-cooler is authorised on condition that this water contains no power boosting additives. The waste gate cannot be installed anywhere else than on the exhaust.

5.7.5.3 In the case of an 'in-line' engine, only one turbocharger is permitted. For a 'vee' engine, only one turbocharger per cylinder bank is permitted. In all cases the turbocharger may only be a single stage type. Variable geometry systems are prohibited. If a waste gate system is used, this may only be fitted on the exhaust side of the turbocharger.

It is strongly advised that a Chalwyn diesel shutdown valve be fitted to the air inlet system or that the oil feed line to the turbocharger has a shut off valve fitted actuated from both inside and outside the cab to reduce the possibility of engine runaway.

5.7.6 EXHAUST SYSTEMS:

The exhaust components after the turbocharger or exhaust manifolds in the case of supercharged engines are free. The exhaust must terminate within the extremities of the vehicle plan view and between the wheels and within 500mm of the ground inside view.

A protection device must be fitted to the extreme end of all exhaust pipes. This device must be made so that any part with a diameter of more than 40mm will not pass directly out of the exhaust pipe. An example of a suitable protection device is strips of steel sheet, 1.6mm thick by 25mm wide, placed edge on to the exhaust gas flow and welded into the end of the exhaust pipe(s) at less than 40mm spacing. Vehicles using a smoke filter at the end of the exhaust pipe do not need the protection described above. It is permitted to fit a 'waste gate' or 'pop off valve' provided such a component is of proprietary manufacture and cannot be installed anywhere other than in the exhaust system.

The exhaust system must be designed such that excessive smoke is not discharged into the atmosphere. An effective smoke filter will be required to be fitted to the exhaust systems if smoke levels are deemed to be excessive by the officials of the race meeting.

Smoke levels may be measured to EEC standards or equivalent and a Judge of Fact will determine unacceptable levels of smoke.

5.7.7 FUEL DELIVERY SYSTEMS:

Fuel injection system parts regulating the quantity of fuel to the engine may be changed, providing that the new parts fit the original location without any modification. The original fuel system design must be retained in its entirety as the manufacturer envisaged e.g., Common rail. The maximum engine free run out speed may be changed. Fuel coolers may be fitted within the periphery of the bodywork.

5.7.8 It is prohibited to run fuel lines inside the cab.

5.8 SUSPENSION:

5.8.1 MODIFICATIONS PERMITTED:

- 5.8.1.1 Ride Height may be adjusted by the re-setting of manufacturer's specification road springs or air springs to lower the ride height to the minimum manufacturer's specification for the vehicle laden to design weight. In the case of multi-leaf steel springs this may be achieved by the removal of one or more leaf from the unit.
- 5.8.1.2 Shock Absorber units may be of any proprietary make and type, provided that their number, their type, and their working principle remain unchanged. The attachment points are free. Rocker arms are forbidden in this kinematic connection of the shock absorber between suspension and no suspended part. Shock absorbers which can be adjusted when the truck is on the move are forbidden. Class 2 trucks must also comply with regulation 5.4.3.1.
- 5.8.1.3 Anti-Roll Bars may be added to the vehicle or standard items modified, as long as they perform no function except for the control of relative lateral roll between axles and chassis. They must not affect axle location, geometry in any way or be capable of being adjusted whilst the vehicle is in motion.
- 5.8.1.4 Castor Angle adjusting wedges may be fitted to any axle but must be securely located by either being welded to the axle spring pad or for it to be impossible for such wedges to be removed without first removing at least two axle/spring clamping bolts. To enable the adjustment of castor it is allowed to modify the front axle (respecting safety) but without cutting, without welding, without removing or adding material. Class 2 trucks must also comply with regulation 5.4.3.2.
- 5.8.1.5 Axles (both driven and steering) may be replaced by any suitable alternative but must be rated by the relevant axle manufacturer as having an on-road weight rating equal to, or greater than, the vehicle's original axles. They must be fixed to the recipient vehicle's attachment points only. The front axle assembly cannot be driven. The axles must be from road-going tractors homologated for the transportation of merchandise with a minimum axle load of 6.7 tonnes for the front and 11.5 tonnes for the rear. These axles must come from an axle manufacturer with a minimum production of 300 units per year.

5.8.1.6 In addition to the leaf springs, the rear axle may have only one torque reaction arm locating on a single position on the chassis, Air suspensions is will only be allowed after written clearance has been obtained from the eligibility scrutineer.

5.8.2 MODIFICATIONS PROHIBITED:

5.8.2.1 Camber Angle on the steering axle may be negative regardless of either the vehicle or the axle manufacturer's specification. One degree of camber is allowed, but with a tolerance of 15 minutes.

5.8.2.2 Non-Ferrous Components may be used for bearing bushes, but it is forbidden for suspension components which have any axle locating function to be made of non-ferrous material even if these are manufacturer's standard specification.

5.8.2.3 With the exception of the permitted modifications listed, it is forbidden to add any components to the suspension or to relocate/realign standard components such as spring shackles. This prohibition includes auxiliary spring devices, auxiliary axle location devices and any device which allows alteration of chassis ride height when the truck is in motion. Adjustments are allowed only by mechanics with the use of tools when the truck is stationary. Subject to 5.8.1.5

The suspension mounting point on the main chassis rails is free, but no part of the spring mounting may be more than 120mm above the top surface of the chassis rail. Rocker arms are forbidden, as is the mounting of the any part of the Suspensions on to the trucks sub-frame.

5.8.3 WHEELBASE / TRACK:

Wheelbase must be within the manufacturer's specification for the vehicle in question. Wheel track must not be increased by more than 150mm over and above that specified by the vehicle manufacturer.

5.8.4 The front axle assembly cannot be driven.

5.9 TRANSMISSIONS:

5.9.1 MODIFICATIONS PERMITTED:

The clutch is free but must be of the friction type. Activation of the clutch must only be initiated by the driver pushing their foot down on the clutch pedal.

The gearbox is free but must come from a commercial range of truck gearboxes with an effective reverse gear. The gearbox must have been produced in a minimum quantity of 300 units per year. Internal components cannot be modified. It must only be possible to activate the 3 or 4 main gears by means of a mechanical lever without exerting any power other than that of the driver.

5.9.1.1 Differentials must be 100% locked and the locking of the differential can only be carried out by the use of tools acting directly on the differential when the vehicle is stationary. Any mechanism that remotely activates or de-activates the locking of the differential is prohibited. The use of any type of limited differential is prohibited.

5.9.1.2 Transmission & Drive Ratios may be changed.

5.9.2 MODIFICATIONS PROHIBITED:

The fitment of automatic gearboxes of any type is not allowed. The distance from the rear of the engine to the front of the gearbox must not be altered from that specified with the original gearbox. Fluid couplings between engine and gearbox are not allowed regardless of the manufacturer's specification. Electronic traction control is prohibited.

5.10 ELECTRICS:

5.10.1 LIGHTING:

All front facing lights fitted, excepting sidelights, must be functional at all times and must not be obscured,

The braking lights must be visible from a position 3 metres to the rear of the truck and 2 metres vertically. No lights other than normal legal lighting may be lit when the vehicle is on circuit, excepting obligatory requirements. All forward facing lamps of more than 32 sq.cm surface area must be adequately protected and secured in case of glass breakage.

Four (4) warning red light + four (4) braking lights are mandatory.

Two (2) red warning / breaking lights must be fixed as high possible on the centreline of the cab.

Two (2) red warning / breaking lights must be fixed at the right and left of the rear of the chassis.

The warning lights must be switched on while the truck is on the track.

The warning red light / braking light must have an area of between 60cm² and 100cm².

The power of the braking lights must be at least 90 lumens. An LED unit may also be used provided it is from a commercial vehicle and the number of LED's must be from 25 to 100 with a minimum diameter of 8mm each.

5.10.1.1 One (1) flashing rain light is mandatory.

The rain light must be fixed at the rear and at the centreline of the chassis.

Rain light dimension see, (FIA TL n°19).

All lights must be visible from a position 3 metres to the rear of the truck and 2 metres vertically and secured in case of glass breakage.

5.10.2 BATTERIES:

Batteries must be capable of starting the engine without any exterior assistance such as 'boost' batteries. Batteries must not be positioned within the cab. They must be securely fastened; each battery to be held down by at least two steel bolts of 10mm minimum diameter. Batteries should not be visible from outside the vehicle and terminals must be covered by a suitable material to prevent terminals shorting to chassis or one another.

5.10.3 GENERATORS / ALTERNATORS:

These must be fitted and remain in circuit at all times, providing an electrical charge to the vehicles' electrical system.

5.10.4 REARWARD FACING RED WARNING LIGHT:

At least 20 watts (maximum 30 watts) must be mounted on the rear panel of the vehicle cab as high as possible and on the vehicle centreline. It must be switched on for the duration of all practice sessions and races. The lit area of this lamp must be between 60cm² and 100cm².

An L.E.D. unit may be used providing it is from a commercial vehicle, with the number of L.E.D.'s between 25 and 100 with a minimum diameter of 8 mm. per L.E.D. In addition to the standard system, it is compulsory to install 2 brake lights (in working order during the race) on the back of the cab, at the height of the red warning light mentioned above.

5.10.5 AUDIBLE REVERSE WARNING:

Vehicles must be fitted with an audible warning that sounds when reverse gear is selected.

5.11 BRAKES:

5.11.1 BRAKING SAFETY SYSTEM:

Double circuit operated by the same pedal: The pedal must normally control all the wheels. In case of leakage anywhere in the brake system piping or any kind of failure of the brake transmission system, the pedal must still control at least two wheels.

All trucks must have a "four circuit" protection valve that isolates the two braking circuits from one another and from other pneumatic circuits. The competitor must be able to demonstrate the two separate brake circuits are functioning.

The only type of braking system allowed will be that using only conventional pneumatic and/or spring actuation only without any other assistance of any other form.

A test point must be fitted to the main air tank so as to allow compressed air to be fed into the vehicles system in the event of the air compressor not working. This test point must be a standard coupling to allow the recovery truck to plug into the trucks air system.

5.11.2 MODIFICATIONS PERMITTED:

There are no restrictions other than as set out in 5.11.3 Brake cooling is permitted using ducted air or water. Cooling ducts must comply with the bodywork regulations 5.6. Brake air reservoirs may be repositioned to allow the fitment of safety devices and/or fuel tank. An effective parking brake system must be fitted which is held on by mechanical energy. The parking brake must be operable by the driver sitting normally with safety belts fastened. The use of disc brakes is allowed provided that the said axle was fitted with disc brakes as original equipment.

5.11.3 MODIFICATIONS PROHIBITED:

The use of any brake system components which are not of proprietary manufacture is prohibited. It is forbidden for the vehicle's air system pressure to exceed 12.0 bar. Any air tanks must be securely attached to the chassis and / or sub-frame and must be approved as being equal to or greater than the working pressure of the system. The use of any brake system components which are not proprietary manufacturer components is prohibited and they must not undergo any modification except for additional air adapters. The primary braking of the vehicle must solely be driven by the foot of the driver, electronic assistance is forbidden. Anti-lock braking systems (e.g. ABS) are forbidden.

5.12 WHEELS/STEERING:

5.12.1 PERMITTED OPTIONS:

Steering wheels are free within the limitations imposed by the following regulations. Driver's steering wheel may be of any proprietary manufacture, a soft rim type is strongly recommended the fitment of a removable type steering wheel is mandatory.

5.12.2 PROHIBITED OPTIONS ROAD WHEELS:

Prohibited Options Road wheels - no part of any wheel rim or tyre fitted to a steering axle may project outward past the plane of the wheel nut/wheel rim interface. Thus, it must be possible to fit two front rims to a rear hub in a twin wheel configuration. The use of non-proprietary manufacture wheels is prohibited as is the modification of proprietary manufacture wheels. No part of the wheel rim or tyre must foul any part of the vehicle under extremes of steering or suspension movement. The wheels on the front axle must be fitted with recessed type wheel nuts and must have a minimum head thickness of 11mm and a minimum diameter of 50mm. Chamfers are requested to avoid sharp edges. Wheel nuts and studs must match the wheel rims being used, to ensure adequate fixing strength. The use of any spacers or adapters between the road wheels and the hub / drum is allowed, these spacers must not have a diameter larger than the supporting face of the rim and must be made of a metallic material. The installation of said spacers must be approved by the Eligibility Scrutineer.

5.12.3 CONSTRUCTION AND MATERIALS:

All the complete wheels of a truck must be standard production parts, unmodified and interchangeable, (i.e., a rear wheel may be mounted on a front hub with no special tools or accessories). Thus, it must be possible to fit two front wheels to a rear hub in twin wheel configuration. The use of split rim road wheels is prohibited. Outer wheels on twin wheel installations must be of metallic steel construction. There is no restriction in respect of wheel material for the remaining road wheels. The use of forged aluminium wheels will be allowed on the outer rear wheels for trucks, but these must be manufactured by either ALCOA, X-LITE or BPW. A further list may be circulated via a Championship Bulletin if alternative suppliers are approved however this may be altered on grounds of safety by the Eligibility Scrutineer and another Championship Bulletin issued accordingly.

5.12.4 DIMENSIONS:

Wheel diameter is unrestricted; wheel rim width is limited to a maximum of 230mm.

5.12.5 On rear twin wheels, the measurement 'a' must be respected in drawing 6.5.6.

5.13 TYRES:

5.13.1 The maximum permitted nominal section width and actual width of the tyre when fitted to the rim is 315mm.

5.13.2 Tyres must be to E.E.C. type approval standard (E.E.C. regulation 54) or equivalent, and must be of tubeless radial steel construction with a speed rating of "L" or higher. Continental racing tyres are strictly prohibited. All tyres fitted must be available through normal retail outlets for all weather road use. Any externally applied chemical compounds which may affect tyre grip are forbidden.

5.13.3 Tyres fitted to the front axle of the truck must be of the same type and be of the same tread pattern and rubber compound. The Organisers reserve the right to issue a single source tyre type and details of where to obtain tyres from via a Championship Bulletin issued by the end of Feb 2021. Alternatively, if a single source tyre cannot be found then alternative tyres approved by the Eligibility Scrutineer which will be on the 2021 BTRC approved tyre list as found in 6.7 may be used. These approved tyres can be used on front and rear axles plus the approved re-treaded tyres may be used on the rear axle.

5.13.4 In the event of a tyre being punctured during a race or qualifying, the officials of the event, if deemed a hazard, will instruct the truck to return to the pit lane for technical inspection via a black and orange flag.

5.13.5 Re-treaded tyres can be fitted to the rear axle only and must have the correct EEC approval.

5.13.6 All tyres must have a tread depth of at least 1.4 mm for the duration of the event.

5.13.7 Re-cut tyres are not permitted, and cross cutting of treads is not allowed.

5.13.8 The use of tyre heating/heat retention devices, tyre treatments and compounds is prohibited.

5.13.9.1 Sensors for measuring tyre pressure when the truck is in motion are allowed.

5.13.9.2 The inside of the tyre (the space includes between the rim and the inside of the tyre) may only be filled with air.

5.13.9.3 All front tyres that a driver plans to use during a Competition must be entered onto the tyre declaration form and be submitted to the Eligibility Scrutineer far enough in advance of the first qualifying session to enable the tyre to be marked before the truck goes onto the track.

5.13.9.4 The times for marking tyres will be advised in an Event Bulletin. It is the Competitors responsibility that the tyres are appropriately marked and/or registered by the Scrutineer. Competitors must accept any possible disadvantage resulting from a non-appropriate marking and/or registering of the tyres. It will be the responsibility of each competitor to ensure that the marking remains intact.

5.13.9.5 The number of marked front tyres that a driver may use during the competition (from the commencement of qualifying) will be advised by a bulletin issued 14 days prior to commencement of the Event. There will be no requirement to have tyres marked at the first event of the 2021 season.

5.13.9.6 Additional "Joker" tyres per truck will be permitted during the season. These will only be available as replacements for tyres nominated for the event and damaged beyond use. This must be agreed with the Championship Eligibility Scrutineer before they are used and applications for use of "Joker" tyres should be made in writing to the Championship Eligibility Scrutineer.

5.13.9.7 The Organisers reserve the right to authorise additional tyres above that specified in 5.13.10.3 should the event format be amended (additional races) or inclement weather or other factors which may necessitate the allocation of additional front tyres. This will be advised to Competitors by bulletin'.

5.14 WEIGHTS:

- 5.14.1 The weight of the truck is with the driver, wearing his complete racing apparel, at all times during the event. The minimum allowed weight for Race Trucks is defined as follows:
5300 kg of which 3150 kg measured at the front wheels.
- 5.14.2 If weight has to be added to comply with the minimum weight, then it must be bolted to the chassis in such a way that it can be sealed by the scrutineers and does not present a safety hazard.

5.15 FUEL TANK/FUEL:

- 5.15.1 Fuel tanks are free in respect of capacity, design, and material. They must be fully proofed against accidental fuel spillage or leakage from fillers and vents. Filler caps must have a positive closure action and it is recommended that these be sealed prior to racing. It is recommended to fit FIA / FT3 safety fuel tanks as described in Article 14 of Appendix J to the International Sporting Code.
- 5.15.2 The fuel tanks must be protected to prevent contact with the propeller shaft in case of failure.
- 5.15.3 The complete tank must be mounted between the internal faces of the chassis rails (od their vertical projection), in front of the centreline of the rear of the rear wheels but behind the cab. The fuel tank must be fixed to two chassis cross members. The fuel tank can have no other function than that of containing fuel.
- 5.15.4 The term "FUEL" shall include all substances fed into the combustion chambers of the engine, excepting only atmospheric air and water vapour contained naturally therein. The use of commercially available diesel fuel is obligatory, that is to say motor fuel produced by an oil company for use in diesel engines.

The only authorised fuels are:

Diesel fuel complying with the following specifications:

BS EN 590 (normal diesel pump fuel), BS EN 14214 (biodiesel), or BS EN 15940 (This includes Gas to Liquid Fuels (GTL) and Hydrotreated Vegetable Oil (HVO))

The use of fuels complying to EN 15940 will be the only fuel allowed for 2022 inline with the FIA.

OXIDANT:

- 5.15.4 Only air may be mixed with the fuel as an oxidant.
- 5.15.5 Any chemical additive, which increases the power, is forbidden.

5.16 SILENCING:

Organisers may at their discretion, carry out noise tests in compliance with the procedures detailed in section J5.17. of the Motorsport UK Regulations. Any competitor whose vehicle is adjudged to produce excessive noise will be required to execute such measures as may be required to reduce noise pollution to an acceptable level, as defined by the meeting organisers.

5.17 NUMBERS/DECALS:

- 5.17.1 Championship decals must be displayed in accordance with Motorsport UK Regulations. Championship decals may be supplied by the championship organisers and in which case the Competitor must make available two areas measuring 350mm x 150mm for these logos on the front of the race truck.

Also, as part of the championship requirements 2 BARC and 2 BTRC decals must be displayed one of each on either side of the truck.

- 5.17.2 Trucks in Class 1 will display black numbers on a white background and those in Class two will display black numbers on an orange background. Numbers displayed on the windscreen must be in reflective yellow and positioned in accordance with Q11.4 & Q11.5.

5.18 MAXIMUM ROAD SPEED:

- 5.18.1 All vehicles, regardless of class, must be equipped with an Organisers approved speed measuring/recording/limiting device. It is the competitor's responsibility to ensure that the speed-measuring device is fully operational throughout the event and correctly calibrated. In either case the device must be installed and operated in accordance with the device manufacturer's instructions. The maximum permitted road speed is 160 kph.
- 5.18.2 Competitors whose vehicles have been shown by any of the above detailed devices to have exceeded this maximum shall be subject to penalties, applicable to the 2018* FIA European Truck Racing Championship and set down in Regulation 4.2 (* These penalties will still be based on 2018 FIA regulations as there is a change to 2020, which the current speed monitoring system has not been configured for).
- 5.18.3 The Championship and Race Organisers, at their discretion may supplement or substitute equipment or carry out any other measures as they deem to be suitable to carry out checks to confirm that competing vehicles are not exceeding the stated maximum speed.

5.19 SMOKE:

For environmental reasons and not least for the visual spectacle of championship events, it is the goal of the Organisers to totally eradicate the emission of black smoke, particularly in Class 2, and reckoned to be caused by inadequate maintenance and poor set-up. Therefore, any truck adjudged to be emitting any visible smoke at any time during an event will immediately be shown the black & orange flag, by decision of the Clerk of the Course alone. If a driver is stopped for smoke, he shall be subject to penalties set down within 4.3.3.

6. APPENDICES

The following Commercial Regulations are “contractual” between the Entrant and / or Driver and the Organisers and / or Promoters and are not considered by Motorsport UK. Accordingly, the application of these Commercial Regulations by the Organisers and / or Promoters will not be subject to the Judicial processes of either the Championship Stewards and / or the Motorsport UK / MSC.

6.1 RACE ORGANISING CLUB:

BARC, Thruxton Circuit, Andover, Hampshire. SP11 8PN
Tel: 01264 882200
Fax: 01264 882233
E-mail: competitions@barc.net

6.2 CONTACTS:

Championship Co-Ordinator:
Name: David Wheadon
Tel: 01264 882209
Email: dwheadon@barc.net

Truck Sport Contact:
Name: Steve Thomas
Tel: 07831 412 044
Email: Steve.Thomas@thomassgroup.com

Eligibility Scrutineer:
Name: Terry Cox
Mob: 01344 762774
Email: terry.cox2@sky.com

6.3 COMMERCIAL UNDERTAKINGS:

6.3.1 PADDOCK LAYOUT:

It is a condition of acceptance / registration into this championship that competitors and teams observe the requirements of the Organisers in respect of the planning / layout of the event paddocks. A nominated member of the Organisers will take responsibility for the co-ordination of paddock layouts and should that nominee require a team or teams to move or re-align themselves to lay out the paddock in a certain way, then that team or teams will comply. Failure to comply with such requests will result in the Organisers levying a non-returnable championship fine (maximum £500). Failure to pay such a fine will involve exclusion from the championship.

6.3.2 ANTI-SOCIAL BEHAVIOUR:

All competitors must note that there is a requirement for everyone that is staying in the paddock overnight to respect the right to the “quiet enjoyment” of others. Therefore, no competitor or associated person shall cause nuisance by means of their unreasonable behaviour whilst in or around the paddock at any time of the day or night. This includes the playing of loud music and the use of noisy generators after 11:00pm at night. Any competitor found in breach of these requirements shall be subject to penalties which may include exclusion from the event, and / or removal from the premises of the venue.

6.3.3 TELEVISION:

By entering the Championship all manufacturers, constructor, competitors, entrants, and teams must assist the nominated TV Company in every way in order to promote the Championship.

6.3.4 ALL MEDIA FORMATS:

All competitors must promote the Championship in the best light through all forms of the media but particularly website and social media forums. Any competitor who might be considered by the Organisers to have brought the Championship into disrepute or to have made derogatory

comments about a fellow competitor or their associated may be called before the Championship Stewards.

6.3.5 OFFICIAL PRESS / MEDIA SESSION:

Registered Championship competitors are expected to make themselves and their truck available for all official press/media sessions as requested by the Championship Coordinator.

6.3.6 TEST SESSIONS:

Registered Championship competitors are permitted to participate in all test sessions arranged by the Organisers. Competitors are not permitted to take part in any other test session without the written permission of the Championship Coordinator, who will then inform, by email, all other competitors of participation in the session(s) and all other competitors are then entitled to take part. Promotional laps undertaken at the request of the circuit prior to a meeting are not counted as a test session.

6.3.7 COMPETITOR & TEAM RESPONSIBILITIES:

The Championship recognises the importance of safe fair racing, in accordance with this it is expected that all competitors, their team members, families and officials;

Respect other participants and their team members

Good clean racing applauding success

Avoiding public criticism of drivers, teams, officials and their decisions

Abiding by the regulations laid down by Motorsport UK and the BARC at all times

Present yourselves, your vehicles and team in a clean, safe and reliable condition

If these elements are not followed, the organisers in conjunction with the Clerk of the Course and the Stewards of the Meeting (or Championship Stewards) may impose penalties.

6.3.7.1 Equipment:

All race trucks and team equipment must arrive at events in a clean, well maintained, and presentable condition. Drivers' equipment including overalls must be clean and presentable at all times.

6.3.7.2 Paddock Arrangements:

All team parking must be in accordance with the official paddock plan which will provide space for the race truck transporter and one van for equipment. All other vehicles including caravans and motorhomes must be parked in the alternative parking areas provided for them at the venue. During the event itself no vehicles may obstruct and paddock roadway.

6.3.7.3 Social Media:

In accordance with Motorsport UK Regulation H27.1.2 you are reminded that the entrant is responsible for the actions of all of those associated with the entry / team be they family or friends. You are also responsible for any social media comments / posts made by anyone associated with the team. No comments / posts should be in any way derogatory towards any other competitor, team member, official or person otherwise associated with an event.

6.4 PENALTIES:

6.4.1 Failure to comply with the requirements of any of the above may result in the imposition of any of the following sanctions:

- a) A formal reprimand,
- b) A fine of up to £5,000, payable to the Organisers,
- c) Disqualification from a meeting
- d) Being banned from taking part in a subsequent meeting or meetings

Anyone who is in receipt of a second reprimand will also be fined a sum of £1,000. Anyone who does not pay a fine will be refused the opportunity to enter the next meeting.

6.4.2 Failure to comply with any part of section 3.1.7 to 3.1.12 inclusive will result in a fine of up to £5,000 payable to the Organisers.

6.5 DRAWINGS:

All applicable drawing for the Championship can be obtained from the Eligibility Scrutineer upon application.

6.6 APPROVED TYRES:

The following tyres are approved for Championship use:

- a) Any tyre sanctioned for use in truck racing by the FIA in the truck racing championship currently Goodyear,
- b) Specific manufacturer that produces a tyre suitable for truck racing are:
 - JK Truck Racing Tyre
 - Giti Truck Racing Tyre Race - Tuned V1
- c) Competitors will be advised by bulletin of tyres approved for use at the non-British events.