



2023 Legends Cars Championship



Organised by:
The British Automobile Racing Club
Thruxton Circuit, Andover, Hampshire, SP11 8PN

PUBLISHED 9 MARCH 2023



CONTENTS

1. SPORTING REGULATIONS – GENERAL	5
1.1 TITLE & JURISDICTION:	5
1.2 OFFICIALS:	5
1.3 COMPETITOR ELIGIBILITY:	5
1.4 REGISTRATION:	6
1.4.6 CHAMPIONSHIP CATEGORIES:	6
1.4.7 DRIVER CLASSES:	7
1.5 CHAMPIONSHIP EVENTS:	7
1.6 SCORING:	7
1.7 AWARDS:	8
2. JUDICIAL PROCEDURES	9
2.1 ROUNDS:	9
2.2 CHAMPIONSHIP:	9
3. CHAMPIONSHIP EVENT MEETINGS & RACE PROCEDURES	10
3.1 ENTRIES:	10
3.2 BRIEFING:	10
3.3 PRACTICE / QUALIFYING:	10
3.4 QUALIFICATION CRITERIA:	10
3.5 RACES:	11
3.6 RACE STARTS:	11
3.7 PRACTICE / QUALIFYING & RACE STOPS:	11
3.8 PITS, PADDOCK & PITLANE SAFETY:	12
3.9 RACE FINISHES:	12
3.10 RESULTS:	12
3.11 TIMING MODULES:	13
3.12 OPERATION OF SAFETY CAR:	13
3.13 ONBOARD CAMERAS:	13
4. PENALTIES	14
4.1 INFRINGEMENTS OF TECHNICAL REGULATIONS:	14
4.2 INFRINGEMENTS OF NON-TECHNICAL MOTORSPORT UK REGULATIONS AND THE SPORTING REGULATIONS ISSUED FOR THE CHAMPIONSHIP:	14
5. TECHNICAL REGULATIONS	15
5.1 INTRODUCTION:	15
PENALTIES:	15
5.2 GENERAL DESCRIPTION:	16
5.2.1 EXAMINATION OF VEHICLES:	16
5.3 SAFETY REQUIREMENTS:	17
6. GENERAL TECHNICAL REQUIREMENTS:	18
6.1 AERODYNAMICS:	18
6.2 AIR FILTERS:	18
6.3 ALTERNATORS:	18
6.4 BALL JOINTS:	18
6.5 BALLAST:	18
6.6 BATTERY:	19
6.7 BOLTS AND FASTENERS:	19
6.8 BRAKES:	19
6.9 BUMP STEER:	19
6.10 BUMPERS AND NERF BARS:	19
6.11 CARBURETTORS:	20
6.12 CHROME PLATING / POLISHING:	20
6.13 CLUTCH OPERATION:	20
6.14 DRIVE SHAFT / PROP SHAFT:	20



6.15	ENGINE COATINGS:.....	20
6.16	ENGINE COOLING:	20
6.17	ENGINE SERIAL NUMBERS:	20
6.18	ENGINE LOCATIONS & MOUNTS:	21
6.19	EXHAUST SYSTEM:	21
6.20	FENDER / WING MOUNTING:	21
6.21	FENDER / WING HOLES & TRIMMING:	21
6.22	FIBREGLASS COMPONENTS:	21
6.23	FIREWALL:.....	22
6.24	FRAME / CHASSIS:.....	22
6.25	FRAME / CHASSIS REPLACEMENT:.....	22
6.26	FRAME / CHASSIS REPAIR:	22
6.27	FUEL:.....	22
6.28	FUEL ADDITIVES:.....	22
6.29	FUEL CELL:.....	23
6.30	FUEL FILTER:	23
6.31	FUEL LINES AND PUMP:	23
6.32	FUEL SHUT-OFF VALVE / FUEL REGULATOR:	23
6.33	GAUGES:	23
6.34	GEAR RATIOS:	23
6.35	GENERAL APPEARANCE OF THE CAR:	24
6.36	GRILLE:.....	24
6.37	GUSSETS:	24
6.38	HEIM RODS / ROD ENDS:	24
6.39	HOOD / BONNET:.....	24
6.40	IGNITION & WIRING SYSTEM:.....	24
6.41	JAM NUTS:	25
6.42	LOWER CONTROL ARMS:.....	25
6.43	MIRRORS:.....	25
6.44	MUFFLING / EXHAUST SILENCING:	25
6.45	NERF BARS:	25
6.46	NUMBERS:	25
6.47	OIL CATCH CANS:	25
6.48	OIL COOLERS & LINES:	25
6.49	OIL CRANKCASE BREATHERS:.....	25
6.50	OIL FILTERS, REMOTE:	26
6.51	PICK-UP POINTS:.....	26
6.52	RACK AND PINION STEERING:.....	26
6.53	RADIOS:	26
6.54	RADIUS RODS / PANHARD BAR:.....	26
6.55	REAR AXLES (HALF SHAFTS):	26
6.56	REAR ENDS / DIFFERENTIALS / AXLE CASINGS:.....	26
6.57	RIDE HEIGHT:	27
6.58	RUNNING BOARDS:.....	27
6.59	SHEET METAL:.....	27
6.60	SHOCKS:.....	27
6.61	SPINDLES / FRONT STUB AXLE:.....	27
6.62	SPRINGS:.....	27
6.63	SPROCKET ADAPTORS:.....	27
6.64	STEERING COLUMN:	27
6.65	STEERING WHEELS:.....	28
6.66	SEATS:	28
6.67	TYRES:	28
6.68	TRACTION CONTROL DEVICES:	28
6.69	UPPER CONTROL ARMS:	28
6.70	WEIGHT:	28
6.71	WEIGHT SAVING MEASURES:	28



6.72	WHEELS:	28
6.73	WHEEL BASE:	28
6.74	WIDTH / HEIGHT / OFFSET:.....	29
6.75	WINDSHIELDS:	29
7.	ENGINES:	30
7.1	GENERAL ENGINE SPECIFICATION RULES:	30
7.2	CRANKING COMPRESSION: ENGINES	30
7.3	XJ1250 SEALED ENGINE SPECIFICATIONS:	30
7.3.17	CAMSHAFTS:	33
7.3.18	CARBURETTORS:	33
7.3.19	CAM CHAIN:	34
7.3.20	CAM CHAIN ADJUSTERS:	34
7.3.21	CLUTCH:	34
7.3.22	CYLINDER HEAD:	34
7.3.23	CRANK SHAFT:.....	34
7.3.24	RODS (CONNECTING):	34
7.3.25	TRANSMISSIONS & GEARSHIFT MECHANISM:	34
7.3.26	VALVES:.....	34
7.3.27	VALVE GUIDES:.....	34
7.3.28	VALVE SPRINGS:	34
8.	APPENDICES	35
8.1	RACE ORGANISING CLUBS AND CONTACTS:.....	35
8.2	COMMERCIAL UNDERTAKINGS:	35
8.3	PROMOTIONAL ACTIVITIES:.....	35
8.4	VEHICLE PRESENTATION:.....	36
8.5	ON BOARD CAMERAS:	36
8.6	COMPETITION NUMBERS / DECALS / Livery:.....	36
8.7	PARTS LIST:	37
9.	DIAGRAMS	38
9.1	DOOR PLATES:	38
9.2	MANDATORY ROOF BRACES:.....	39
9.3	OPTIONAL ADDITIONAL FRONT PLATE:	39
9.4	OPTIONAL ADDITIONAL REAR GUSSETS:	40
9.5	FRONT CLIP – PERMITTED GUSSET REINFORCEMENT:	40
9.6	REAR AXLE.....	41
9.7	STEERING RACK PLATE.....	41
9.8	DOOR PLATES	42
9.9	ADDITIONAL REINFORCEMENT REAR AXLE:	42
10.	APPENDIX – RACE WITH RESPECT	50

BARC Championships support Motorsport UK and the Race With Respect campaign. By registering to compete you agree to respect the code of conduct. This way everyone can race in a safe, welcoming and fair environment. #RaceWithRespect





1. SPORTING REGULATIONS – GENERAL

1.1 TITLE & JURISDICTION:

The Legends Cars Championship is organised and administered by the British Automobile Racing Club Ltd (BARC) in accordance with the General Regulations of the Motorsport UK (incorporating the provisions of the International Sporting Code of the FIA) and these Championship Regulations. The organisers reserve the right to issue additional statements clarifying items in the rules and Regulations and all such statements will be issued to all registered Drivers by posting to the address details on the registration form or by means of a Technical Bulletin emailed to all registered Competitors (D11.2 applies)

Motorsport UK Championship Permit No: CH2023/R038

Race Status: Interclub

Motorsport UK Championship Grade: Grade C

1.2 OFFICIALS:

1.2.1 Co-ordinator: Phil Cooper 600 Racing UK Ltd

1.2.2 Licensed Eligibility Scrutineer: Richard Williams Motorsport UK

1.2.3 Championship Technical Advisor: Simon Pocklington 600 Racing UK Ltd

1.2.4 Championship Stewards:

Bob Lentell	BARC
Brian Hemmings	BARC
Pat Blakeney	BARC
Ian Watson	BARC

Any three Championship Stewards will constitute a quorum. In the event of any of the Championship Stewards listed above being unavailable or being unable to consider any particular matter due to a perceived conflict of interest, the organisers reserve the right to appoint an alternative Championship Steward or, if deemed to be necessary, more than one alternative Championship Steward.

Any three of the Championship Stewards may sit to make a decision. In accordance with G2.7, Championship Stewards may only adjudicate on any disputes, irregularities or appeals arising from the approved Championship Regulations. Under G2.7.1, Championship Stewards are also empowered to consider any request from the Championship co-ordinator to penalise any Competitor for any breach of Championship Regulations after holding a formal hearing to impose a penalty in accordance with C.2.1.1 (subject to the rights of appeal provided for in Section C). Under W2.2.1, the Championship Stewards can only adjudicate upon any disputes, irregularities or appeals arising from the approved Championship Regulations. They are also empowered to consider any request from the Championship Co-ordinator to penalise any Competitor for breach of Championship Regulations and after holding a formal hearing, to impose a penalty in accordance with C.2.1, subject to the rights of appeal to the MSC provided in Section C.

1.2.5 Championship Clerk of the Course: Mark Hulme and nominated deputies

1.3 COMPETITOR ELIGIBILITY:

1.3.1 Entrants must:

- be current members of the BARC and
- be Registered for the Championship and
- be in possession of a valid Motorsport UK Entrants Licences.

1.3.2 Drivers and Entrant/Drivers must:

- be current racing members of the BARC and
- be Registered for the Championship and
- be in possession of valid Competition Race Club status Licence, as a minimum or
- Or be in possession of the highest grade of national Race licence or valid FIA International Licence, together with their ASN's written consent ((H)25.2. and FIA ISC Article 2.3.7.b applies).



- e) If participation in the Championship requires absence from education a Driver, in full time school education is required to have the approval of their head teacher and a letter stating such approval from their school in order to fulfil registration for the Championship. A Driver shall not take time out of their education to participate in motor sport without the prior written approval of their education establishment.
- f) Agree to abide by the Motorsport UK Race With Respect campaign at all times to promote a safe, enjoyable and fair environment (See Regulation 1.4.5).

1.3.3 All necessary documentation must be presented for checking at all rounds when signing-on. This will include both the competition licence and club membership card.

1.3.4 Competitors must ensure that their cars comply with the conditions of eligibility and safety throughout qualifying and racing.

1.4 REGISTRATION:

1.4.1 Registration for the Legends Cars Championship and/or Legends Cars Elite Cup with JLM is strictly by invitation from 600 Racing (UK). All Competitors must register for the championships, whether they are competing as an individual or as part of a team (see 1.4.6), by returning the Registration Forms to 600 Racing (UK) prior to the Final Closing date for the first round being entered.

NOTE: to be eligible for Championship points and awards Drivers must have registered with 600 Racing (UK) a minimum of 21 days in advance of their first race. All Drivers registering for the Championship do so, on the proviso they undertake not to bring the Legends Cars Championship into disrepute and if by doing so, they may forfeit the right to any Championship points accrued and the right to compete in future rounds maybe taken away upon decision by the Championship Stewards.

1.4.2 A Registration Fee of £800.00 will be applicable for the Legends Cars Championship, bank details for payment are contained within the registration form.

An additional registration fee of £400.00 plus VAT is applicable for entries to the Legends Cars Elite Cup with JLM.

1.4.3 Registrations will be accepted from November 2022 until further notice.

1.4.4 Registration numbers will be the permanent Competition numbers for the Championship. Each registered Driver will be allocated a permanent number for the season by the Championship Co-ordinator. Guest Drivers will start at the back of the grid and will not be awarded points.

1.4.5 By registering for the Championship all Competitors and their associates commit to positively promote and demonstrate the Motorsport UK's Respect Code which is appended to these Regulations (Appendix – Race with Respect).

1.4.5.1 Where any reports of disrespectful conduct are judged to be well founded the Championship organisers may issue warnings or require remedial actions and/or report the matter to the Championship Stewards who may impose appropriate penalties which can include loss of Championship points and/or race bans through to Championship Expulsion and referral to Motorsport UK.

1.4.5.2 It is imperative that we promote the safety and wellbeing of young people and adults at risk. In addition to this all participants must be aware of their behaviour and conduct at all times and abusive language and harmful behaviour will not be tolerated. Any such incidents must be reported to the Championship Coordinator and/or Safeguarding Officer who will also relay the report Motorsport UK. Details of the Motorsport UK Policies and Guidelines are available at www.motorsportuk.org/resource-centre by selecting Policies and Guidelines.

1.4.6 CHAMPIONSHIP CATEGORIES:

Each Championship has two registration categories, 'Individual' and 'Team'.

Registering as an 'Individual' Competitor, the Driver will be issued with a race number which they must display upon whichever car they are driving irrespective of whether the car is self-owned, hired or borrowed.

Drivers electing to compete as a 'Team' must each register as per the conditions in 1.4.1 making it clear that it is a team registration. Racing as a team means that two or more Drivers must share one car for a minimum of 2 (two) full race Events and it will be the 'car' that carries the race number. The car cannot be substituted only the registered vehicle can be used. The VIN number to be included on passport.



All points awarded and penalties will be awarded to that 'car' and shared, in effect, by all the Drivers within the team. Any Driver within the team who is classified as a 'Rookie' shall be subject to the provisions of novice stature (1.4.6) and shall be eligible for Driver Class awards. Teams will only be allowed to enter one Driver in each round.

NB: A Driver must compete as either 'Individual' or as a 'Team' member. Driver cannot do both at the same time. They may switch from one category to the other at any point providing that notification of the change has been given to the Championship Co-ordinator, in writing, at least 21 days before it takes effect. Points gained as an 'individual' cannot be transferred to a 'team' or vice versa.

Any guest Driver sanctioned by the Organisers to compete in any Event would need to hold the appropriate race licence (1.3.2). These Drivers would not need to be registered for the Championship as points will not be awarded.

1.4.7 DRIVER CLASSES:

All Drivers entering their first race having never previously raced a LEGENDS CAR competitively shall be classified as a 'Rookie' for that season and must start at the back of the grid for the first six (6) races.

1.5 CHAMPIONSHIP EVENTS:

The 2023 Legends Cars Championship will be contested over 8 Rounds (4 meetings) as follows:

ROUND	DATE	VENUE	CLUB
1 & 2	15/16 April	Cadwell Park	BARC
3 & 4	17/18 June	Brands Hatch (Indy)	MSVR
5 & 6	7/8 October	Snetterton	MSVR
7 & 8	4/5 November	Brands Hatch (Indy)	BARC

The 2023 Legends Cars Elite Cup with JLM will be contested over 6 Rounds (3 meetings) as follows

ROUND	DATE	VENUE	CLUB
1 & 2	6/7 May	Brands Hatch (Indy)	TOCA/BARC
3 & 4	29/30 July	Croft	TOCA/BARC
5 & 6	12/13 August	Knockhill	TOCA/BARC

1.5.1 In accordance with Motorsport UK Regulation D11.2 & Q7.11. The organisers reserve the right to amend the published list of dates and rounds, in which case, all registered Competitors will be informed of the amendments by Official Bulletins posted to the address specified on the Official Registration Form.

1.6 SCORING:

1.6.1 Points for the Legends Cars Championship and Legends Cars Elite Cup with JLM will be awarded under the same principles.

Points will be awarded to Competitors listed as classified finishers in the Final Results as follows:

1 st	200 points	10 th	100
2 nd	185	11 th	90
3 rd	170	12 th	80
4 th	160	13 th	70
5 th	150	14 th	60
6 th	140	15 th	50
7 th	130	16 th	40
8 th	120	17 th	30
9 th	110	18 th	20

All other classified finishers will receive 10 points and all other starters who are non-finishers 5 points, unless they were disqualified.

1.6.2 Scores from the total number of Events run will counted to determine Championship placings.

1.6.3 Championship points and awards will be scored as per 1.6.1 above. In the Event of a tie at any Championship Event Championship points will be divided equally between the tied places, however, a tie-break system, outlined below



will be employed on the day to determine the trophy positions of Competitors who tie within the top three positions. This will be as follows:

The system, in the first place, will be based on the number of cars that each Competitor has overtaken in both races. The Drivers classified finish position will be subtracted from their balloted grid position to give a figure for their 'improvement' in each race. (i.e. if a Competitor started 11th on the grid and finished 3rd their 'improvement' would be $11 - 3 = 8$). The Competitor with the highest 'improvement' factor across both races, when added together, would be the winner of the tiebreak for trophy purposes only.

If the situation is still tied after his calculation then, for the second tie break, the Competitor with the highest finishing position in their first race would win the trophy for the tied position. If the position is still tied then the highest position in the second race would be the determining factor.

If the position is still tied, then the highest position in the race that the Competitors raced together will be the final determining factor.

NB: The system outlined above is solely for determining the trophy positions on the day and does not affect the award of overall Championship points for that day.

1.7 AWARDS:

1.7.1 All awards are to be provided by 600 Racing (UK) and by the Organising Club.

1.7.2 Per Race: Award to Winner, 2nd and 3rd supplied by the Organising Club.

1.7.3 Championship: Trophy to 1st, 2nd and 3rd

Rookie award per round providing that at least two Rookie Drivers are competing.

Masters Award - McCosh/Napoleon Award (For Drivers over 40).

Team Car Award (provided there are at least 3 team entries).

All Drivers are expected to attend the Legends Awards Presentations at the end of the season (dates and venue to be announced in the Drivers Newsletter via email). Failure to attend a presentation ceremony may result in any award that may have been made being withdrawn.

An additional Award to the Overall Champion will be provided by the BARC and will be presented at the BARC Championship prize-giving at the end of season (date and venue to be announced by the BARC). Any Driver failing to attend may not be eligible to receive any prizes which may have otherwise have been presented at this function. Such prizes may be withheld and not be represented to any other Driver.

1.7.4 Bonuses:

The Organisers / Sponsors / Promoters reserve the right to provide additional awards for and during the Championship.

1.7.4 Presentations:

Awards and / or Trophies are to be provided for presentation at the end of each race or at an end of the meeting presentation ceremony. Drivers must attend any presentation for which the organisers have given reasonable notice. All Drivers taking part in podium presentations must be wearing racing suits.

1.7.5 Entertainment Tax Liability:

N/A

1.7.6 Title to all Trophies:

If Provisional Results or Championship Tables are revised after any presentations and these revisions affect the distribution of awards the Competitors concerned must return them to the organisers in good condition within 7 days.



2. JUDICIAL PROCEDURES

2.1 ROUNDS:

In accordance with Section C of the current Motorsport UK Yearbook and these Regulations.

2.2 CHAMPIONSHIP:

In accordance with Section C of the current Motorsport UK Yearbook and these Regulations.

3. CHAMPIONSHIP EVENT MEETINGS & RACE PROCEDURES

3.1 ENTRIES:

- 3.1.1 Competitors are responsible for sending in correct and complete entries with the correct entry fee prior to the closing date for entries, which shall be 10 days before each round.
- 3.1.2 Incorrect or incomplete entries (Including Driver to be nominated entries) are to be held in abeyance until they are complete and correct and the date of receipt for acceptance of entry purposes shall be the date on which the Secretary of the Meeting receives the missing or corrected information or fee.
- 3.1.3 Any withdrawal of Entry or Driver/Car changes made after acceptance of any entry must be notified to the Meeting Organisers in writing. D25.1.12 applies.
- 3.1.4 The Maximum Entry Fee for each round shall be: As detailed in the Supplementary Regulations for each Event.
- 3.1.5 Entries will be accepted on a first come first served basis up to the maximum number permitted to race on the Motorsport UK Track Licence for the Event in question. No reserves will be accepted.
- 3.1.6 Each Competitor must present their engine passport, engine build report form and chassis declaration to the Championship Eligibility Scrutineer or their nominated deputy before a scrutineering ticket will be issued.

3.2 BRIEFING:

There will be a Drivers Briefing at each Event, after qualifying practice, where practical (H33.1.3 applies).

3.3 PRACTICE / QUALIFYING:

- 3.3.1 The minimum period of practice to be provided is to be as specified in the Motorsport UK Regulations in respect of the circuit lengths.
- 3.3.2 Should any Practice Session be disrupted, the Clerk of the Course shall not be obliged to resume the session or re-run sessions to achieve the Championship criteria and the decision of the Clerk of the Course shall be final.

3.4 QUALIFICATION CRITERIA:

Each Driver must complete a minimum of 3 laps practice in the car to be raced and in the correct session in order to assume his or her balloted grid position. Where a Driver fails to qualify in the correct session, they will have to start from the back of the grid for the race in whichever race their balloted grid position is nearest to the front. Should the Clerk of the Course and /or the Stewards of the Meeting deem that this subsequently creates a gap or gaps on the grid that may compromise the safety of the race start, they may order that all cars assume their balloted grid position by reason of force majeure. In such cases, this decision would apply for all races within a Championship round. The Clerk of the Course and/or the Stewards of the Meeting shall have the right to disqualify any Driver whose driving is considered to be unsatisfactory – as per Motorsport UK Regulation G15. or may instruct the Driver to start from pit lane for the first race. The situation may be reviewed in respect of the start position of the second race. If the Competitor has incurred an infringement in familiarisation or practice, or their pace was not of the required standard, the Clerk of the Course and /or Stewards of the meeting may instruct the Driver to start from pit lane for all races. The Driver must compete in the same car in the Championship races that they used for Qualifying practice.

- 3.4.1 Practice times set will not count towards the starting grid position. These will be determined by a blind draw prior to the first race. Competitors will be notified of their grid standing by means of a bulletin posted on the official notice board.
- 3.4.2 Any Competitor who at the discretion of the stewards brings the sport / formula / Event into disrepute via the Media / Press / television or the public address system may be subject to the penalty listed in 3.4.4.
- 3.4.3 Any Competitor that disregards 3.4.2 may be subject to a fine of £500.00 and will be deducted a maximum total of points for two rounds of the Championship, also being demoted to start from pit lane in both races for the following two meetings he/she competes in. In addition, the Driver concerned will not be invited to race in the Championship after the end of the current season.
- 3.4.4 The grid for the Heats will be determined by ballot, the grid for the 1st heat will be as per the ballot and the grid for the 2nd heat will be the reverse of the ballot plus the swapping of sides.

The grid for the final race will be determined from the aggregate result (points scored) in the heats, with the lowest points at the front and the highest at the back of the grid.

Where this process results in tied scores the grid position will be resolved by reference to the highest position achieved in heat one.

Note: In every race the 'Novice Class' (Rookie) will form up behind the last Driver except where that Driver is at the back of the grid because of a penalty or is a guest Driver.

3.5 RACES:

The standard minimum scheduled distance shall be no less than 6 laps (specified as a number of whole laps) but should any race distance be reduced at the discretion of the Clerk of the Course or Stewards of the Meeting it shall still count as full points scoring round.

3.6 RACE STARTS:

All cars should be in the holding area 20 minutes prior to their race, thus allowing cars to be positioned in their respective place on the dummy grid. At the point that the cars are released on to the grid any Competitor who is not ready will be required to start from the pit lane.

3.6.1 Cars will leave the Assembly Area behind the Pace Car to start their rolling lap(s). The exact procedure will be outlined in the Drivers Briefing for each Event.

3.6.2 Towards the end of the Rolling Lap(s) the pace car will leave the circuit after extinguishing its roof lights indicating that a start is imminent. Cars must maintain the speed set by the Pace Car, prior to it accelerating away to leave the circuit, which will normally be 30 mph. Any visible increase in speed of the front row of the grid prior to the red light being extinguished will be deemed to be an infringement and will result in a time penalty being applied. The same penalty will apply to any car breaking rank/formation before passing the start line with the exception being that any car having a problem should indicate this by putting a hand out of the window and pulling towards the side of the track which will be the sign that following Drivers should pass.

3.6.3 Any cars deemed to have jumped the start or be out of position on the start will be given a 20 second time penalty which will be indicated by the Competitor being shown a time penalty board on the start line, along with their number. Any car creating an unnecessary gap between itself and the car in front on a race start (or re-start) will be deemed to be out of position and given a start time penalty.

3.6.4 Any Drivers unable to start the Green Flag/Pace lap within 30 seconds of the Pace Car starting the rolling lap(s) will be allowed to start from the pit exit after the last car to take the start has passed the exit point. Any Drivers unable to maintain grid positions on the Green Flag Lap to the extent that ALL other cars are ahead of them, may complete the Green Flag lap but must remain at the rear of the last row of the grid.

3.6.5 Aborted Start:

If the start is aborted prior to the pace car pulling off, the pace car will not extinguish his roof lights and will continue to lead the field around the circuit for an additional lap and a new start will be attempted. The race will not start until the pace car pulls off of the circuit, the signal to start will not be given, and the start lights may remain at red. When this signal is given, all cars should exercise extreme caution and return slowly round the circuit maintaining their original grid positions stopping on the grid. The race start procedure will then be repeated from the showing of the one-minute board indicating that the green flag / pace lap is imminent. At the discretion of the Clerk of the Course, the race distance may be reduced accordingly. In the event of any starting lights failure the Starter will revert to the use of the National Flag.

3.6.5 Excessive weaving to warm-up tyres - using more than 50% of the track width, and falling back in order to accelerate and practice starts, is prohibited.

3.7 PRACTICE / QUALIFYING & RACE STOPS:

3.7.1 Should the need arise to stop any race or practice; red lights will be switched on at the Startline and red flags will be displayed at the Startline and at all Marshals Signalling Points around the Circuit. This may be supplemented by the showing of red lights around the circuit.

This is the signal for all Drivers to cease circulating at racing speeds, to slow to a safe and reasonable pace and to return to the pit lane, during practice, and to the starting grid area, during a race, unless otherwise directed by officials.

3.7.2 Cars may not enter the Pits unless directed to do so or repairs are necessary. Work on cars already in the Pits must cease when a race is stopped and may only continue under the control of a Scrutineer. Cars in the Pits may not re-join the grid.



- 3.7.3 All Competitors who are able to take part in any restarted race may do so in accordance with Q.12.16.
- 3.7.4 In the event that a race is stopped after the leader has completed two or more laps any restart will be in accordance with Q.12.15.2 except that the restart will be a rolling start, with cars in single file and there may be no overtaking until you have passed the startline after the green flag has been displayed.

3.8 PITS, PADDOCK & PITLANE SAFETY:

- 3.8.1 Pits & Paddock: Competitors must ensure that the Motorsport UK, Circuit Management and Organising Club Safety Regulations are complied with at all times. In addition, any paddock plan issued by the Organisers must be complied with and the minimum amount of space should be used when setting up.

For the Legends Cars Elite Cup with JLM, additional paddock and Event Regulations will be issued in advance by TOCA and must be adhered to. Failure to do so will result in fines as detailed by TOCA.

- 3.8.2 Pit lane: The outer lane or lanes are to be kept unobstructed to allow safe passage of cars at all times. The onus shall be on all Drivers to take all due care and respect the pit lane speed limits. No-one under the age of 16 is permitted access to the pit lane unless they are the holder of a Motorsport UK Junior Race licence.
- 3.8.3 Refuelling: May only be carried out in accordance with the Motorsport UK General Regulations, the Organising Club Regulations, Circuit Management Regulations and the SRs or Final Instructions issued for each Circuit/Meeting. A fire extinguisher is compulsory in every pit area.
- 3.8.4 Speed Limit Pit Lane Speed Limit will be 40 m.p.h.

3.9 RACE FINISHES:

- 3.9.1 After taking the Chequered Flag Drivers are required to:
- progressively and safely slow down,
 - remain behind any Competitors ahead of them,
 - return to the Pit Lane Entrance/Paddock Entrance as instructed,
 - comply with any directions given by Marshals or Officials,
 - keep their helmets on and harnesses done up while on the circuit or in the pit lane,
 - place their car into the Parc Fermé where it must remain until released by the Championship Eligibility Scrutineer or his deputy.
 - Attend any podium presentation that may be required.
- 3.9.2 PARC FERME: After each race the vehicles must be presented directly for scrutineering. Any area deemed necessary by the Licensed Eligibility Scrutineer and/or his nominated representative will be subject to Parc Fermé conditions with no exceptions. This will include the track from the Finish Line to the scrutineering area; the waiting area in front as well as the track from the scrutineering area to Parc Fermé, but all areas may be used as necessary.
- 3.9.3 Team personnel must not enter Parc Fermé unless invited by the Eligibility/Safety Scrutineer and/or his nominated representative. Should unauthorized team personnel be present in these areas, the breach will be reported to the Clerk of the course who may impose penalties as appropriate. This restriction will also apply when team facilities are utilized as the nominated Parc Fermé area
- 3.9.4 If blowers are required to cool the engines they are to be passed to the Driver who will attach it to the car. Cars must remain in the designated Parc Fermé until formally released by the Championship Eligibility Scrutineer, or nominated representative. The Eligibility Scrutineer may allow x 1 team member to enter Parc Fermé.
- 3.9.5 In the event that the Licensed Eligibility Scrutineer requires a Competitor to strip or remove a part from a Competitor's vehicle then only one team member of the team may undertake the work, the Driver may be present as well. If additional team personnel are required this will be at the discretion of the Eligibility Scrutineer

3.10 RESULTS:



All Practice Timesheets, Grids, Race Results are to be deemed Provisional until after completion of any Judicial or Technical Procedures, which may be at the end of the season (particularly note section 7 of these Regulations).

3.11 TIMING MODULES:

- 3.11.1 It is the Competitors responsibility to ensure that a working transponder is fitted to the vehicle in accordance with Q.12.8.1. No electronic equipment may be placed within five metres of any official timing line and any breach of this may result in the confiscation of the equipment concerned.
- 3.11.2 All timing modules must be fitted on the right side of the engine firewall (Engine side). Any car found not to be fitted with a transponder may have their result from that heat disallowed
- 3.11.3 Competitors cannot use electronic timing equipment on race days. Only the official timing services (i.e. TSL) can be used.

3.12 OPERATION OF SAFETY CAR:

- 3.12.1 The Safety Car will be brought into operation and run-in accordance with Section Q, Appendix 3 of the Motorsport UK General Regulations.

3.13 ONBOARD CAMERAS:

It is mandatory to fit at least 1 forward facing camera to the vehicle, which must be functioning at all times and use the supplied memory card as issued by 600 Racing (UK). The footage is the property of 600 Racing (UK) and must be made available to the Clerk of the Course and the Stewards. The Clerk of the Course and the Stewards reserve the right to make use (including copies) of any footage recorded during an Event to assist in reaching their decisions on any judicial matters. Within 60 minutes of the completion of the final race of the end of the Event the footage from this camera must be delivered to the Championship support vehicle. Entrants are permitted to make a copy of the footage for personal use during this time window.

Entrants are permitted to fit additional cameras, these must be approved by the Scrutineer. Any footage obtained must not be used for commercial use

All cameras fitted must record footage at a minimum of 720p resolutions.

Failure to have cameras operating and able to provide post-race footage will result in a 50-point deduction from that race.

4. PENALTIES

4.1 INFRINGEMENTS OF TECHNICAL REGULATIONS:

CHAMPIONSHIP PENALTIES:

As Legends Racing is synonymous with family & amateur motor sport the following penalty system will apply. Entrants and teams entering this Championship, once signed on to partake in any Event of this Championship accept that their car(s) will conform to these technical Regulations at all times. Motorsport UK Scrutineers can make inspections at any time during the meeting and any infringements will be subject to the penalties contained in these Regulations.

For all minor technical infringements these Regulations provide for the deduction of Championship points even if this results in a minus total of Championship points. If the Regulation is deemed to be minor then the penalty will be shown directly behind the technical heading of these Regulations. If no penalty is shown then the provisions of Motorsport UK Regulations C3.5.1. shall apply. Under some rule headings part of the rule carries a minor rule infringement penalty & any other infringement under that heading will be dealt with under the Motorsport UK Regs C3.5.1. this is stated within the penalty statement.

If a penalty point deduction technical infringement is found the Clerk of the Course will interview the Driver & will deduct Championship points as per these Regulations. All points deductions will be made at the end of the meeting. The technical infringement must be rectified prior to the next practice or race. Failure to rectify the infringement for the next practice or race the provisions of Motorsport UK Regulations C3.5.1. shall then apply, the point deduction will still stand.

4.2 INFRINGEMENTS OF NON-TECHNICAL MOTORSPORT UK REGULATIONS AND THE SPORTING REGULATIONS ISSUED FOR THE CHAMPIONSHIP:

4.2.1 As per current Motorsport UK Judicial Procedure Regulations.

4.2.2 For infringements of non-technical Motorsport UK Regulations and the sporting Regulations issued for the Championship, the Championship Stewards shall have the authority to disqualify Driver(s) from the Championship for a defined period. As per the Current Motorsport UK Judicial Procedures Regulations and the provisions of these Regulations.

Should two separate penalties be applied, then all points shall be forfeited for that whole Event, irrespective of the timing of the offence committed at that Event. Where a “double header” Event take place at the same venue over a weekend and is conducted as two separate race days then this Regulation shall only be applied to each day individually.

4.2.3 PENALTIES:

For breach of Regulations the number of points will be determined not by reference to the type of offence but the type of penalty imposed (C2.1.7):

Verbal Warning:	0 points / no deduction of Championship points
Formal written reprimand:	2 points / plus 50 Championship point deduction
Fine or time penalty:	3 points / plus 100 Championship point deduction
Disqualified from heat or race:	4 points / plus 150 Championship point deduction
Disqualified from the meeting:	6 points / plus 600 Championship point deduction

Grid Position – after a penalty whereby a Driver receives a driving or technical penalty, that Driver will start from pit lane for the next race in which he/she competes therefore not giving an advantage.

If required any offence can be referred to the Championship Stewards for further penalties if appropriate.

4.2.4 Competitors breaching 3.8.4 will be subject to penalties as provided for in Motorsport UK Regulations, typically being a fine of £10 per mph in excess of the limit during practice or qualifying and a Drive Through Penalty during race.

5. TECHNICAL REGULATIONS

5.1 INTRODUCTION:

The following Technical Regulations are set out in accordance with the Motorsport UK specified format and the Race Car must comply with these Technical Regulations. All modifications not allowed by these Technical Regulations are expressly forbidden. As a general policy for guidance; UNLESS IT IS EXPRESSLY PERMITTED THEN IF IT DOESN'T SAY YOU CAN, THEN YOU CANNOT. All parts of the race car must be as manufactured and supplied by 600 Racing (UK) / 600 Racing UK's official parts supplier, no tolerances, unless specifically stated, are implied.

For the purposes of these Regulations the term Licensed Eligibility Scrutineer will be deemed to include his nominated representative. The Eligibility Scrutineer will be advised by the Championship Technical Advisor regarding matters of eligibility and technical compliance.

It is the Competitor's responsibility to prove eligibility compliance of his car, not the Licensed Eligibility Scrutineer to prove non-compliance.

No Legends Cars parts supplied by 600 Racing (UK) / 600 Racing (UK)'s official parts supplier may be modified in any way without written permission from the Championship Eligibility Scrutineer which will be communicated to all registered Competitors by means of a Technical Bulletin.

Registering for the Championship Competitors will be deemed to have full knowledge of these Regulations, and to have accepted the same in full.

600 Racing (UK) have the right to request to the Championship organisers that the Championship Stewards consider a Driver / entrant to be disqualified for a race, complete meeting or a period of time, should that Driver/entrant bring disrepute to Legends Cars Racing.

600 Racing (UK) reserve the right to place identification labels / marking on controlled parts to ensure these parts have been purchased through 600 Racing (UK) / 600 Racing (UK)'s official parts supplier. Distribution existing controlled parts on cars and any spares held by Drivers or teams may also be labelled / marked. Once parts have been labelled / marked any unlabelled / unmarked parts will be deemed to be illegal. All labels and security stickers MUST remain in original form and original location – do not paint over. Controlled parts must carry a security sticker and are listed in paragraph 8.7 non labelled parts will be deemed illegal. It is the responsibility of the Driver to make sure the security stickers are in place.

All registered Competitors must carry Engine Passport updated at all times to each Event for Scrutineer Check. See paragraph 3.1.6

PENALTIES:

Breach of Regulations Motorsport UK Regulation C3.1.1:

- a) If the Eligibility Judges of Fact agree that any vehicle or component is ineligible, this will be reported to the Clerk of the Course (or the Championship Stewards where the Clerk of the Course has no Championship function) who, after consulting all parties will disqualify the vehicle from the relevant results, unless there exists exceptional circumstances.

Breach of Regulations Motorsport UK Regulation C3.5.1:

- a) Unless the Regulations for a Championship specify a different penalty, any Competitor in a Race Championship whose vehicle is disqualified from the results in accordance with C3.1.1 or C3.1.2 will subject to the following Championship penalties. These will be applied whether the Championship is for Drivers or entrants.
 - The Event will be counted as one of the Events contributing to their total Championship score.
 - The Competitor will be disqualified from the Event forfeiting all Championship points and other awards.
 - The Competitor will forfeit a total of points equal to those obtained from two first places, even if this penalty results in a minus total of points.

Any car finishing a race under its own power that does not report through Parc Fermé will be classed as DNF for that race, irrespective of its actual finishing place on the track.



5.2 GENERAL DESCRIPTION:

The Legends Cars Championship and Legends Cars Elite Cup with JLM is for Competitors participating in a Legends racing car supplied by 600 Racing (UK) / 600 Racing UK's official parts supplier. Cars under second or subsequent ownership will be eligible providing they were first supplied by 600 Racing (UK) / 600 Racing UK's official parts supplier. They will also be eligible for other Events in the UK and Europe providing that the Event has been officially sanctioned for Legend Cars. Legends cars are either the "Coupe" or "Sedan" although there are eight versions which can be used supplied through 600 Racing (UK) Ltd / 600 Racing UK's official parts supplier. 600 Racing (UK) Ltd will consider alternative models that are derived from either a "Coupe" or "Sedan" to be entered into the Championship on an individual basis, entries will be considered on their individual merit, commercial benefit to the Championship and any other factors as needed. The decision to accept entries into the Legends Cars Championship using alternative models is at the sole discretion of 600 Racing (UK) Ltd and is final. A list of entries using alternative models will be published via bulletin at the start of each season.

600 Racing (UK) reserve the right to request spot checks be carried out at any time during a race meeting. The spot check can include the removal, and temporary substitution of the part for testing. This will be done subject only to the fact that such spot checks by themselves shall not affect the Driver's / entrant's ability to take part in the races.

The Championship Eligibility Scrutineer (or on his instructions, any other licensed Eligibility Scrutineer) can demand a Competitor to submit their engine including carburettors gearbox, complete car or part thereof for stripping, examination or testing at a nominated time and location decided by the Eligibility Scrutineer. The parts may be sealed until the examination and may be either:

- a) Given direct to a specialist (if present at the track) for inspection at the nominated time.
- b) Retained by the Eligibility Scrutineer for inspection at the nominated time.
- c) Have the component transported (at the Competitor's cost) to the specialist by the nominated time with the seals intact.

The Competitor can be present whilst the Licensed Eligibility Scrutineer and 600 Racing (UK) specialist carry out the examination. The car or any parts thereof may be removed or retained for further testing or examination.

600 Racing (UK) reserves the right to use any 600 Racing (UK) authorised engine builder as the nominated specialist. This specialist will provide any assistance necessary for the Eligibility Scrutineer to carry out the checks. The Competitor may change the ignition timing & camshaft timing (if applicable) under the supervision of the Motorsport UK Scrutineer.

Any item or items found to be illegal will need to be replaced with legal parts before a Competitor competes in further races all cost of such work will be met by the Competitor / entrant concerned

5.2.1 EXAMINATION OF VEHICLES:

TECHNICAL CHECKING:

- a) The Championship Eligibility Scrutineer/Championship Organisers reserve the right to inspect, test, measure, seal or impound any component or liquid (including fuel) fitted to or used in conjunction with any car registered in the Championship either personally or through a nominated representative. Any cost associated with scrutineering or eligibility inspections (including but not limited to transportation, checks, inspections, rebuilds etc.) will be the sole responsibility of the Entrant / Driver.
- b) Entrants must at all times comply with the directives of the Championship Eligibility Scrutineer and the Championship Organiser in respect of scrutineering and eligibility checking.
- c) Any component sealed by a Motorsport UK Official must remain sealed and may not be tampered with in any way. In the event of a seal needing to be broken for repair or replacement, prior to doing so the Championship Eligibility Scrutineer must be informed in writing and approve the seal being broken. Re-sealing will take place after technical checks have been made at the next race meeting, or by an authorised engine builder.
- d) All components and parts on the vehicle that are deemed relevant to safety, performance and legality of the vehicle may be required to carry Championship seals.
- e) All Championship seals fitted to a car and its relevant parts will be recorded by the Championship Eligibility Scrutineer in the vehicle Log Book (passport).

- f) Queries concerning eligibility should be referred in writing to the Licensed Eligibility Scrutineer at least seven days prior to an Event entered to permit a ruling in advance of any meeting at which it is intended to compete. Electronic communication is an acceptable format for this purpose.
- g) Tests to establish the power output of any car may be carried out by the organisers or their representatives. Such power testing will be used using a rolling dynamometer equipment.
- h) Components on Competitor's cars may be verified by comparison with the similar components sourced from the Official 600 Racing (UK) parts van and the sourced components will be deemed to be the legal parts.

5.3 SAFETY REQUIREMENTS:

The following Articles of Motorsport UK Appendix K Safety Criteria Regulations will apply:

K1, K2, K3, K4, K5, K6, K7, K8, K9, K10, K11, K12, K13, & K14

Additionally:

- a) Protective padding must be applied and securely fixed to those parts of the roll cage with which the Driver's body or helmet could come into contact with. All roof and side rails must be covered in protective padding.
- b) Towing points at the front and rear must be fixed to the front and rear frame rail and must be indicated by yellow paint (or a clearly visible contrasting colour) and marked with the word 'Tow'. Towing eyes must be of suitable strength and attached to the car fit for the purpose of towing, any injury or accident resulting from the failure of a towing point will be the responsibility of the Driver/entrant. Towing eyes may not protrude beyond the ends of the chassis frame rails.
- c) Door release bolts must be fitted horizontally on the inside of the doors in a centre position (as originally fitted on import from the USA). This applies to both suicide and normal opening doors. The release bolt handle must be painted in neon paint in contrast to the inside door colour. It is highly recommended that two or three spot welds are added to the centre section of the door hinge to prevent it unfolding in an accident.
- d) A plumbed in fire extinguisher system must be fitted and must conform to Motorsport UK Regulation K3.1. The extinguisher system must be homologated on either FIA Technical list 16 or 52.
https://www.fia.com/sites/default/files/l16_approved_extinguisher_system_22.pdf
https://www.fia.com/sites/default/files/l52_approved_plumbed-in_extinguisher_system_8865_29.pdf
- e) The use of a Frontal Head Restraint Systems (FHR) according to the FIA Code, standard 8858-2010, is mandatory. The helmet manufacturer must certify the tether anchorages and their mounting. For clarification on clothing standards and for details of homologated systems and approved helmets you may refer to the FIA website, www.fia.com.



6. GENERAL TECHNICAL REQUIREMENTS:

At the start of each Event, practice or race each car will be presented in a manner that represents the formula. The organisers reserve the right not to issue the relevant paperwork to allow a car to be scrutineered, if it is felt not to be of an acceptable standard of preparation, this will include the presentation of a neat, clean and 'stock' appearance of a Legends Car, with any previous crash damage having been fully repaired.

Such repairs must also extend to all cars that become "tired" so as to maintain a high quality presentation grid of Legends Cars.

Legends Cars are designed to race in their standard/stock form only, this includes all aspects of their appearance (excluding paintwork & decals). Only those adjustments and additions specifically permitted under these Regulations are allowed, otherwise any other changes will be deemed illegal.

Standard / Stock parts for Legends Cars, including body panels, must be obtained from 600 Racing (UK) / official distributor Handy Distribution. Non-standard / stock parts are free within the control limits of these Regulations.

Legends Cars have a waiver under the following provisions of the Motorsport UK General Regulations - J5.2.6 and J5.20.8 (CTE-2023-53).

6.1 AERODYNAMICS:

Spoilers, air dams or any other aerodynamic devices are not permitted.

6.2 AIR FILTERS:

Only 600 Racing (UK) / 600 Racing UK's official parts supplier air filters and outer wear pre-filter coverings are permitted. Air filters may not have an element more than 3" in height (bottom of filter element to top). Velocity/ram stacks are not permitted. No air filters that direct air flow to the carburetors or increase air flow are permitted (included those with moulded ram stacks). The air filter element must not contain, either inside or outside, any heat shields or air deflectors of any description. No additional items are permitted within the air filter other than the element itself. The use of ram pipes is prohibited. Air filters constructed with fibreglass parts are not permitted. No ducting to increase the air flow to the air filters is permitted.

6.3 ALTERNATORS:

Modification to the charging system is not permitted. The alternator must be charging at all times. No switches or electronic devices that disconnect the alternator are permitted.

6.4 BALL JOINTS:

The upper and lower ball joint must remain stock, within the stock dimensions, steel thickness location and configurations supplied by 600 Racing (UK) / 600 Racing UK's official parts supplier and may not be reinforced in any way. For the purpose of checking dimensions, the Licensed Championship Eligibility Scrutineer may select a ball joint from the 600 Racing (UK) Parts supplier van and compared the dimensions against the similar component on the Competitor's car One or two (Minimum ¼" – Maximum 7/16" width) jam nuts are permitted on the upper and lower ball joints. Each ball joint must use at least one jam nut. The jam nuts may not be welded to any component. Additional Split pins or R Clips are acceptable as nut locking devices.

6.5 BALLAST:

A maximum of eight blocks of lead are permitted. The blocks may be no larger than 12" x 1.5" x 2.5" which will weigh no more than 20lbs and the stacking of blocks is illegal. Two blocks of lead may not be in contact with each other. All lead must be clearly visible with neon paint or tape wrapping and marked with the car number. Ballast may not be added by any other method, including steel shot or any other material in frame rails, bumpers, nerf bars or any other component. Blocks must be directly bolted through the oblong frame rails only using two 3/8" or equivalent bolts & lock nuts, blocks or any ballast may not be placed anywhere inside the Driver's compartment, the Scrutineer's decision will be final on the safe mounting of ballast blocks.

The provisions of Motorsport UK Regulation J5.15 refers as a minimum.



6.6 BATTERY:

Only a battery with the dimensions of 7 1/8" x 8" x 6 1/2" may be used. A top post or side post battery may be used. Motorcycle batteries may not be used. The battery must remain in its stock location on the rear bulkhead and securely mounted. The original stock battery bracket may not be altered in any way. See drawing section, measurement 5 3/4" from chassis rail.

It is not permitted to fit a lithium battery.

6.7 BOLTS AND FASTENERS:

Only the equivalent stock or upgraded steel fasteners and bolts may be used on the Legends Car. Fasteners may be drilled for safety (maximum wire hole size 3mm) wire but intentional weight saving modifications are not permitted. Aluminium and titanium or other lightweight fasteners are illegal. Bolts secured in their standard or currently supplied positions with 'Nyloc' nuts (i.e. steering rack, shock absorbers, panhard rod, seat belts, engine bolts, track rods, rod ends and others) must be secured using a full depth 'Nyloc' not a half nut, and two clear bolt threads must show past the nylon lock.

6.8 BRAKES:

Any of the brake parts that are attached to the rear axle or the spindles (front stub axles) must remain stock, within the stock dimensions, steel thickness, location and configurations supplied by 600 Racing (UK). The car must have operational brakes on all four wheels and must lock up all four wheels during inspections (Brake lines may not be plugged or completely shut off). Any type of cooling duct to the brakes is prohibited. The right or left side brake pedal may be removed. Steel brake lines / 'cupro nickel lines' may be substituted for steel-braided brake lines and re-routed to give greater protection. No rubber or copper brake lines are permitted. The Wilwood brake system must be used as supplied by 600 Racing (UK) / 600 Racing UK's official parts supplier and must carry the INEX logo plus the silver security sticker. Only Mintex 1144, 1166 or F4 pads carrying the Legends logo can be used and must be supplied directly by 600 Racing (UK) / 600 Racing UK's official parts supplier.

BRAKE ROTORS/BRAKE DISCS:

Only steel discs (not drilled or reduced in diameter) with a maximum diameter of 254 mm are permitted on the front. The minimum permitted thickness of the disc is 8mm wide.

BRAKE DRUMS:

Only drums (not drilled or lightened) are permitted on the rear, supplied by 600 Racing (UK). The minimum weight of the brake drum is 10.0lbs (ten pounds)/4.5kgs. Intentional metal removal of the brake drum for lightening purposes is illegal.

BRAKE MASTER CYLINDER:

The brake master cylinder must remain stock, within the stock dimensions, location and configurations supplied by 600 Racing (UK) / 600 Racing UK's official parts supplier. The brake master cylinder must remain on the engine side of the firewall.

BRAKE PROPORTION VALVES:

Any number of aftermarket brake proportion valves for the brakes are permitted, but complete elimination of the brake at any wheel is prohibited.

6.9 BUMP STEER:

Adjustments for bump steer settings will only be permitted by placing spacers above or below the track rod ends. No other modifications to change bump steer is permitted (i.e. altering position of steering rack or pick-up points on the spindles).

6.10 BUMPERS AND NERF BARS:

The front and rear bumpers must remain the standard dimensions, steel thickness, location and configurations supplied by 600 Racing (UK). They must be securely fastened with nut and bolt, no other method permitted. One additional bolt per frame rail may be added to secure the tab. No other securing devices including safety wire and plastic cable ties may be used only the tab must connect from the frame to the bumper. Wire tethers must be used both front x 2 and rear x 2 at all times.

At the start of each practice or race straight undamaged bumpers (front and rear) will only be allowed to compete with un-repaired straight tabs of the maximum dimensions of mild flat steel material. The distance from the end of

the chassis rails to the rear of bumper uprights (both front & rear) will be no less than the official tab gauge which measures approx. 25mm (but the gauge will be the official gauge). See diagrams section for bumper dimensions. If a bumper (front or rear) becomes dislodged whilst on track the Competitor must enter pit lane for the bumper to be re attached (to the satisfaction of the scrutineer) or a replacement bumper be fitted. It is not permitted to re-join the track without a bumper.

6.11 CARBURETTORS:

The carburettors and float bowls must remain as stock Yamaha FJ1200/XJR1200/(XJR1250 sealed) supplied by 600 Racing (UK). Only carburettor jets and needles may be replaced and only stock adjusters used. No other modifications to the carburettors or float bowls are permitted. Modifications or components to increase or restrict airflow to the carburettors (such as velocity stacks, heat deflector shields, internal modifications not listed above) are not permitted. Only the OEM heat shield between the carburettors and engine is permitted and may not be altered in any way.

Plastic topped carburettors are not permitted.

The inlet rubbers must have the marking 36Y on the component and may not be altered in any way.

Throttle inlet diameter maximum 36mm and may not be machined or polished or altered in any way.

Choke diameter maximum 29mm and may not be machined, polished or altered in any way.

The Carburettor piston and Diaphragm may not be altered in any way from the manufacturer's specification, other than the diaphragm hole may be enlarged but must not exceed 4mm.

6.12 CHROME PLATING / POLISHING:

Parts such as bumpers, nerf bars, wheel rims and valve cam covers may be chrome plated or polished. Suspension parts may be nickel, zinc or similarly plated.

6.13 CLUTCH OPERATION:

Rubber or steel-braided clutch lines are permitted. The master and slave cylinder must remain stock, (Yamaha part number SEA 16381-00) in their original positions and configurations. The clutch pedal may be 'cranked' over to give greater Driver leg comfort, but only in conjunction with removal of the left side brake pedal. No needle bearing upgrades allowed.

6.14 DRIVE SHAFT / PROP SHAFT:

The drive shaft, flanges and u-joints must remain within the stock dimensions, steel thickness location and configurations and supplied by 600 Racing (UK) / 600 Racing UK's official parts supplier with a silver security sticker visible at all times. Lightening the drive shaft in any way is illegal.

A 600 Racing (UK) approved drive shaft retainer strap is permitted. A maximum of three retainer straps of ¼" thickness and ¾" width are permitted.

6.15 ENGINE COATINGS:

Only the coatings as supplied stock from the factory are permitted throughout the engine. However, removal of any coatings is permitted at rebuild. Exhaust manifold pipes may be wrapped in manifold heat wrap or painted with a non-ceramic coating

With permission of 600 Racing (UK) it is permitted to paint the engine with "standard" engine paint that doesn't alter the thermal properties of the engine.

6.16 ENGINE COOLING:

An extra fan(s) internal duct work (approved by 600 Racing (UK) remote oil filter, header wrap, and oil cooler is permitted, oil coolers must comply with these Regulations see Oil Cooler Section. Any extra cooling fans fitted cannot hamper the scrutineer carrying out compression checks in Parc Fermé.

6.17 ENGINE SERIAL NUMBERS:

All engine casings must have a genuine YAMAHA serial number. An engine seal will be attached by Series Scrutineer or his nominated representative that must remain in place at all times and will be recorded in the Engine Passport. Any engine casing without a serial number will be considered illegal and not be permitted to be used in any 600 Racing (UK) sanctioned Events.



6.18 ENGINE LOCATIONS & MOUNTS:

The engine and upper and lower engine mounts must remain within the stock dimensions, steel thickness (no aluminium mounts), location and configurations currently supplied by 600 Racing (UK) / 600 Racing UK's official parts supplier. The right side of the engine may be fitted with an additional aftermarket steel mounting no more than 4½" wide, no mounts may be welded to the frame rails apart from the two right side factory fitted lugs. If the optional right-side mount is used the original mounting lugs/brackets on this side may be removed. No engine mounts can be angled or altered in any way.

6.19 EXHAUST SYSTEM:

A "stock" system only is permitted.

The header (manifold pipes), collector, down pipe and silencer box must be supplied by 600 Racing (UK). The internal and external components of any of the stock exhaust system pipes or silencer (LC1009, 1010, 1012, LC105X00X501 (1)(2)(3)(4)) cannot be altered in any way. Header wrapping tape is permitted. The silencer must be the current production and supplied by 600 Racing (UK) / 600 Racing UK's official parts supplier. The only official permitted collector will be the current part supplied by 600 Racing (UK) / 600 Racing UK's official parts supplier which will be stamped with 600 Racing (UK) identification (LC105X00X521).

The provisions of the current Motorsport UK Yearbook Section J5.16 apply.

Collector Position – the centre of the weld of the collector (where the four manifold pipes go into one chamber) shall be positioned between 40mm and 100mm forward of the firewall bulkhead.

Maximum OD of any manifold pipe is 38.5mm, maximum OD of the down pipe (Collector to silencer) is 44.75mm. Silencer as approved and supplied by 600 Racing (UK) Ltd only.

Stainless steel pipes, silencer, and manifold supplied by 600 Racing (UK) are permitted.

6.20 FENDER / WING MOUNTING:

Stock fender / wing mounts may not be altered from the original (i.e. moving the inside of the fender/wing away from the grill). No additional mounts are permitted; the closest mounting holes to the grill must be used.

Removal of the fibreglass on the body half under the rear wings is permitted. Competitors are required to carry out this modification, as it substantially aids safety checks of the rear axle pick-up points, chassis and other components.

6.21 FENDER / WING HOLES & TRIMMING:

A maximum of seven holes in each of the front wings for air circulation and cooling of the engine is permitted, the diameter of these holes may not exceed 4". The outside edge of the front wings and the bottom of the front wings may not be trimmed. The inside edge of the left-hand wing (exhaust side) may not be trimmed. The inside edge of the right-hand wing (carburettor side) may only be trimmed to allow the 600 Racing (UK) approved and supplied one piece air filter by 600 Racing UK's official parts supplier, to fit with minimum clearance. No holes are permitted in the rear wings or body shell apart from the trimming to allow for the exhaust silencer to clear the L/H rear wing, this to be kept as close to the exhaust system as practical. The outer edge of the rear wing may be trimmed for additional tyre clearance, but the wing contour must measure at least 10" from the main body shell. Measurements will be taken from a point on either rear wing above top dead centre of the tyre. The original standard position of wings to the body shell & frame must remain as supplied on each model.

6.22 FIBREGLASS COMPONENTS:

All fibreglass body components must be purchased from 600 Racing (UK) / 600 Racing UK's official parts supplier and must carry the authorised decal & Silver security sticker of 600 Racing (UK), and may not be reinforced or intentionally lightened in any way with the exception of 6.20. These components must be securely attached to all cars. Any car failing in this regard can be disqualified from the Event.

All body parts must remain in their standard location and must be supplied by 600 Racing (UK) / 600 Racing UK's official parts supplier. All body panels must be of the same model and must be secured to the frame rails and should sit on top of the rear chassis rail but may be raised by 1¼". The back lower edge of the rear fender must sit within the 2" side of the frame rail.

The rear window of the 34 Ford Coupe has a measurement of 23" x 8 1/8" (plus or minus 1/8"). The hood should not be more than 4 degrees from the horizontal when compared to the horizontal parts of the chassis / sub-frame. The deck lid spacing may be of no more than ¼" as a maximum.



6.23 FIREWALL:

A metal firewall is mandatory supplied by 600 Racing (UK) / 600 Racing UK's official parts supplier only. A removable inspection plate is permitted in the firewall, but it must be totally sealed whilst the car is on track.

Cars must have a protective bulkhead of non-flammable material between the engine & fuel tank and the Driver/passenger compartment capable of preventing the passage of fluid or flame. Gaps must be sealed with suitable flame proof material that completely closes any gap at all times.

6.24 FRAME / CHASSIS:

The "Big Boy" chassis is allowed in competition and must be supplied by and registered with 600 Racing (UK). All chassis' and frames running as Legends Cars must be produced and purchased through 600 Racing (UK) / 600 Racing UK's official parts supplier and must carry the serial number assigned to the car. The serial (VIN) number can be found on the Legends number plate on the chassis. This plate should be clearly visible at all times and not tampered with in any way. It will also be included on the passport.

Gussets: Strengthening gussets may only be added in the spots described in the Technical Diagrams. No stock gussets may be removed. Additional strengthening of the pickup point on the frame for the 6½" rear axle upper radius rod is permitted subject to, any additional gusset or tube must be similar in dimensions and thickness to those around this pick-up point, the bolt may only pass through the original pick-up point currently supplied by 600 Racing (UK) pick-up point thread and no other (apart from a lock nut if so desired). The strengthening bar under the front clip to chassis joint as shown in the Technical Diagrams is mandatory.

It is highly recommended to have the frame checked by an expert for metal fatigue every 12 months or following a major incident. Any Legends Car Chassis over four years old must be stripped and examined by an expert to ensure that it is fit for the purpose of racing, a copy of the report should accompany the car at all times. Cracked or broken frames are strictly prohibited from any 600 Racing (UK) sanctioned Event.

Suicide doors are only permitted on 600 Racing (UK) factory OEM frames, no changing of the original door hinging positions is allowed. The chassis cannot be modified or altered in any way, apart from the modifications allowed in these Regulations or for any reason from the stock chassis supplied by 600 Racing (UK).

6.25 FRAME / CHASSIS REPLACEMENT:

Should the chassis become severely damaged, replacements must be purchased through 600 Racing (UK) / 600 Racing UK's official parts supplier. The Competitor must give the damaged chassis including VIN plate to 600 Racing (UK) for disposal before a new chassis will be released to the Competitor, the replacement VIN plate will then be approved. If a chassis is deemed unrepairable by 600 Racing (UK) the chassis plate must be removed and presented to the Championship Co-ordinator.

6.26 FRAME / CHASSIS REPAIR:

Front and rear clips only may be replaced.

The clips must be purchased from 600 Racing (UK) / 600 Racing UK's official parts supplier. The Drivers compartment of the frame, (roll bars, cross braces etc.) may not be repaired or replaced if damaged or altered in any way. The Licensed Eligibility Scrutineer reserves the right to disallow a repaired car which does not appear to have been properly repaired.

6.27 FUEL:

The Organisers have mandated the use of a control fuel which all Competitors must use in all Championship rounds.

For 2023 Carless Fuels through their agent Vital Equipment is the nominated supplier. The fuel will include JLM additive to reduce emissions making Legends Cars more carbon friendly and have a correlation figure of no less than 0.99500.

A minimum of 3 litres of fuel must be present at the end of any practice or race for fuel sampling purposes.

6.28 FUEL ADDITIVES:

Only JLM additive is approved. No other additives are permitted.

6.29 FUEL CELL:

The fuel cell (plastic or metal) supplied by 600 Racing (UK) / 600 Racing (UK)'s official parts supplier must be used in its stock form & location, foam is mandatory in all fuel cells as supplied by 600 Racing (UK) (cars are not permitted on track without the foam in place). Fuel cell cap gaskets must be in place and kept in good condition. The stock as originally supplied method of holding the fuel cell line in place cannot be modified in any way. Fuel cooling devices are not permitted. Any plastic fuel cell will be fitted with an underside stone guard (This can be aluminium). All fuel cell caps must be clearly marked with the cars race number. Large plastic cap fuel tanks are no longer permitted. For all models an additional plate / modification as tank protection is mandatory. Fuel not to be stored below ambient temperature in the car.

6.30 FUEL FILTER:

Aftermarket fuel filters may be used. No glass fuel filters will be permitted.

6.31 FUEL LINES AND PUMP:

Fuel lines must not be routed through the Driver's compartment, all fuel lines must be flexible steel braided pipe or cupro nickel pipe. Suitably mounted to prevent chafing, only one 'stock' supplied by 600 Racing (UK) fuel pump is permitted (LC955X00X013). The ID of the fuel pipe must remain the same as the original supplied by 600 Racing (UK) fuel pipe. Fuel lines may not be attached to or routed with any electrical wires. The fuel pump must be the standard pump OEM supplied by 600 Racing (UK) / 600 Racing UK's official parts supplier (A 3psi pump only).

6.32 FUEL SHUT-OFF VALVE / FUEL REGULATOR:

Aftermarket fuel shut-off valves and fuel regulators are permitted.

6.33 GAUGES:

The only gauges permitted are ones that record the following: engine rpm, exhaust gas temperature, lap timer, oil pressure and oil temperature. Gear change lights are also permitted. The following information must not be recorded: O2 mixture (oxygen/fuel). Throttle position sensor; brake line PSI or any suspension information, no data logging systems are permitted. Data logging also includes the use of on-board cameras that show any part/s of the inside of the Driver's compartment including gauges and instruments, this is not permitted. 200-point penalty will be imposed. Data logging is the collection, storage or transmission of data on the performance of a vehicle by means of a combination of electronic memory, and or a series of sensors and looms or GPS sensors.

Lap times, oil temp and oil pressure may be recorded in car only by the UK Legends Cars supplied AIM dash. This information can only be viewed in car on the 600 Racing UK / approved distributor supplied dash and cannot / does not have a facility to be downloaded. The 600 Racing approved dash is a sealed unit, if the seal is broken the part is no longer eligible to be used".

No data may be downloaded on a software program, for viewing on any form of display. Nor may any information on the vehicle's performance have any Driver instrumentation connected to it, nor may any track display of information be given to the Driver. On board timing is allowed providing it produces a time for a complete lap. GPS is not permitted, and data cannot be downloaded to a lap top or any similar device. The only other timing information allowed will be by means of the bulletins issued by the official Championship timing company.

6.34 GEAR RATIOS:

The only differential gear ratio permitted is a 2.93 The gears must remain within the stock dimensions, steel thickness, location and configurations supplied by 600 Racing (UK) / 600 Racing UK's official parts supplier. The use of any other unauthorised gear ratio is illegal.

1st 40/14 (2.857)

2nd 36/18 (2.000)

3rd 33/21 (1.571)

4th 31/24 (1.292)

5th 29/26 (1.115)

Primary reduction ratio 98/56 (1.750)

Secondary reduction 39/18 (2.167)



In addition, it is permitted to fit an after-market knob / stick but the standard pivot and links below the pivot must be retained. The maximum length above the tunnel is 6".

6.35 GENERAL APPEARANCE OF THE CAR:

All Competitors must present a neat, clean and stock appearing car for any 600 Racing (UK) sanctioned competitions. Crash damaged cars must be repaired to the minimum technical standards and approved by the Licensed Eligibility Scrutineer before returning to competition.

The Licensed Eligibility Scrutineer will report to the Clerk who may deny a car from competing if it does not meet the minimum acceptable standards as mentioned above.

6.36 GRILLE:

The steel grille must remain within the stock dimensions, steel thickness, location and configurations delivered by 600 Racing (UK) and may not be reinforced in any way. The grille must be the same model as the hood grille shell & front fenders that are used.

6.37 GUSSETS:

Strengthening gussets may only be added in the spots as described in the appendices. Strengthening the upright that holds the pick-up point of the short top link rod from the rear axle is permitted. (See Technical Diagrams)

6.38 HEIM RODS / ROD ENDS:

Only steel rod ends supplied by 600 Racing (UK) / 600 Racing UK's official parts supplier or of the same dimensions are permitted on a Legends Car. The stock rod ends are designed to bend/break and absorb energy under impact, the Competitor accepts the responsibility and risk of upgrading rod ends. Rod ends may be upgraded, but aluminium, titanium or other lightweight rod ends are not permitted.

6.39 HOOD / BONNET:

Any bonnet hole(s) or louvers must be on the Left Side (Cylinder Side) of the bonnet, which means no hole(s) or louvers may be on the Right Side (Carburettor Side), over a line drawn from the centre of the front bonnet pin to a point which is the centre of the rear of the bonnet. Bonnet Louvers or are defined as aluminium plates with maximum 3/8" edges. The size of the holes will be 2 x 4" diameter max holes in the hood. It is not permitted to run with the rear of the bonnet raised.

6.40 IGNITION & WIRING SYSTEM:

The complete ignition/engine control system must be the original OEM parts for Yamaha. The stock ignition control box (black/red box) must remain in its original position supplied by 600 Racing (UK) on the front bulk head engine side on the right hand side as viewed by the Driver. A 600 Racing (UK) approved ignition control box and ignition plate is permitted, neither of these ignitions can be modified or tampered with in any way, the RPM limiter must be in proper working order at all times and must remain unmodified and not tampered with in any way. Only one ignition box per car is allowed. Current cars are approved but all rebuilds and new cars must have a factory standard wiring loom.

The wiring harness, must be the standard factory production part number LC155X00X001 supplied by 600 Racing (UK) with the quick fit connectors to allow easier engine removal are permitted, only in-line fuses are permitted (no fuse blocks). All wiring must have visible connections (no junction boxes).

Electronic throttle controls (traction) are not permitted.

Coils, Coil Wires and Spark Plug Boots: Coils (black/red) must be "stock" supplied by 600 Racing (UK). The spark plugs and boots may be replaced with any aftermarket type with similar thread size, resistors must remain in the spark plug boots. The coils and leads may be replaced with 'Dyna 3 Ω' from a 600 Racing (UK) approved supplier.

The 'stock' coil mount must remain in its currently supplied position by 600 Racing (UK). A 600 Racing UK Ltd air deflector / coil mount is also approved.

No aftermarket electronic ignition advances are permitted. At all times the "blue" cover must be in place while on circuit.

600 Racing (UK) reserves the right to provide a substitute ignition/engine control system to any Competitor at random at any time. The 600 Racing (UK) approved system will be exchanged for the Competitor's system and must be used for that Event. 600 Racing (UK) is not responsible for any failure of the component(s) supplied.

Re-positioning of the ignition, starter, choke, gear position indicator & rear light switches only to a small panel on the inside of the right-side door is permitted. Or projecting them from the standard Legends dashboard position by no more than 4 inches maximum and by means of a simple sheet metal fabrication only. This is to assist those Drivers having difficulty reaching the dashboard whilst strapped in. A 600 Racing (UK) supplied f / glass dash pod currently installed are acceptable but all future installations must be the approved pod supplied by 600 Racing (UK) / 600 Racing UK's official parts supplier only.

Electronic cut out and Fire extinguisher pulls or buttons must be located on Drivers right hand side in front of the windscreen. A mandatory plate supplied by 600 Racing (UK)'s official parts supplier must be used to reinforce the underside of the fibreglass where these parts are located.

REAR FOG WARNING LIGHT:

A rear fog light must be fitted with a surface of 80 x 70mm min and using a 21 watt bulb or LED and be in working order as per Motorsport UK Regulation Q.13.10.8 / K5.1. No forward-facing lights of any description are allowed.

6.41 JAM NUTS:

At least one jam nut is required to be used with all rod ends, clevis ends and ball joints. One or two (Minimum ¼" - Maximum 7/16" width) jam nuts are permitted on the upper and lower ball joints. Split Pin or R Clip in addition are acceptable.

6.42 LOWER CONTROL ARMS:

The lower control arms must remain stock, within the dimensions (12½" x 16¼"), steel thickness, location and configuration delivered by 600 Racing (UK) and may not be altered in any way. Each measurement will have a tolerance of +/- 1/8" (0.125").

6.43 MIRRORS:

All cars must have an interior rear-view mirror with a minimum area of 6". One pair of external mirrors must be mounted outside the doors, but each external mirror must not exceed a maximum of 10"sq. inches area, and secured with a maximum of two fittings (i.e. two nuts and bolts, two pop rivets, two machine screws etc.).

6.44 MUFFLING / EXHAUST SILENCING:

Silencing will be in accordance with Motorsport UK J5.17. Section B Measurement will be made at 0.5m from the end of the exhaust pipe with a microphone at an angle of 45 degrees with a maximum permitted level of 108db.

6.45 NERF BARS:

The nerf bars must remain within the stock dimensions, steel thickness, location and configurations delivered by 600 Racing (UK), and may not be re-enforced in any way. No other types of nerf bars are permitted.

6.46 NUMBERS:

See Section 8.

6.47 OIL CATCH CANS:

An oil catch can (minimum 250ml maximum 600ml capacity) must be used. It must be securely fastened and remain within the engine compartment.

6.48 OIL COOLERS & LINES:

Oil coolers must be cooled by air only (no dry ice systems or other type). All oil cooling systems (including lines) must be mounted in the engine compartment only. No oil coolers or lines may be mounted in the Drivers compartment or in or on the rear deck or fuel cell compartment. More than one oil cooler is permitted. Oil cooler fans are permitted. Ductwork behind the oil cooler to direct hot air away from the engine is permitted, this ductwork must not protrude below or outside the frame rails. Push-lock fittings are permitted. Oil coolers may not be mounted below the bottom of the front bumper, all oil coolers must be securely mounted on mild steel mounting rails or plates and drilled only for fasteners or outlets for oil lines. Oil cooler air scoops are permitted (with a maximum of 1/8" sheet metal (aluminium permitted)) but must be kept completely within the frame rails and must not project lower than the front bumper.

6.49 OIL CRANKCASE BREATHERS:

The only place that the crankcase may have a breather is a) under the carburettors at the stock outlet or b) from the oil filler cap. Crank case breathers must be directed to the catch can via a tube.



6.50 OIL FILTERS, REMOTE:

Remote oil filters are permitted and must be mounted in the engine compartment only. Inside or outside mounting of the remote oil filter to the frame rail is permitted. The remote oil filter must be located in a position where it cannot be easily damaged in the event of an accident. Remote oil filters may not be mounted below the bottom of the front bumper.

6.51 PICK-UP POINTS:

Absolutely no modifications of the frame, pick-up points or spindles will be permitted unless referred to in these Regulations or advised by Official Bulletin in writing to all Competitors. Only one pick-up point for the panhard bar on the frame is permitted in the standard location. Damaged or bent spindle(s) and or pick-up points must be repaired by the beginning of the next race. Only one $\frac{3}{4}$ " mild steel spacer is allowed and this is to be fitted in its original intended position between the rear axle panhard rod and the axle casing pick-up point. All other spacers will be either $\frac{1}{4}$ " or $\frac{1}{2}$ " and of mild steel material.

6.52 RACK AND PINION STEERING:

Only the rack and pinion steering box supplied and stamped '600 Racing' or 'Mid-State Machine' is permitted. Any other marked or unmarked steering box is not permitted. Two additional gussets are permitted to the steering rack mounting plate (See Technical Diagrams). New improved part available from 600 Racing (UK) $\frac{1}{4}$ " thick plate.

6.53 RADIOS:

The use of one or two-way radio systems at any time for any reason is prohibited. Radio wiring looms are not permitted within a Legends Car at any race for any reason. A one-way RACEceiver system will be mandatory for all Competitors at every Event, under the control of the Clerk of the Course. Any Driver not wearing a working RACEceiver in either practice or race will not be allowed to take up their start position until rectified (they may start from pit lane once the RACEceiver is working if they have run out of time to take up their rightful position) this will be operated in compliance with Q11.3(a (iv)).

6.54 RADIUS RODS / PANHARD BAR:

The radius rods and panhard bar must remain stock dimensions (radius rods – either 6 $\frac{1}{2}$ ", 11" or 12" in length panhard bar 23 $\frac{1}{2}$ " in length, 6" rod only to be used on Big Boy chassis), aluminium thickness, location and configurations of the original, supplied by 600 Racing (UK). Each measurement will have a tolerance of +/- 1/8" (0.125"). Steel radius rods or panhard bars are not permitted. The 11" and 12" rods may be interchanged anywhere on the car as long as the car still meets all other specifications contained within the formulae rules.

6.55 REAR AXLES (HALF SHAFTS):

The long and short rear axles must remain two piece, within the stock dimensions, steel thickness, location and configurations supplied by 600 Racing (UK), and may not be altered or reinforced in any way. The outer face of the half shaft, or shaft modified for lightening purposes or axle casings not in accordance with the rules are not permitted. New one-piece axles supplied by 600 Racing (UK) must carry the INEX logo. Shaft dimensions as per drawing in the Technical Diagrams.

6.56 REAR ENDS / DIFFERENTIALS / AXLE CASINGS:

Only the 10 bolt pattern 5/8" wide flange Toyota, locked steel rear ends are permitted. All rear end components and pick-up points must meet the specifications of the original stock components as when the Legends Car was supplied 'New' with 0 camber +/- 1 degree tolerance (scrutineer check after practice, before race one). Double Shear housings are permitted, see Technical Diagrams. The rear end must be locked (all spider gears welded or a steel spool of a minimum 6.0 lbs (six pounds) weight supplied by 600 Racing (UK) only). No limited slip differentials, aftermarket differentials, quick change rear ends, floaters, homemade or otherwise permitted. Only OEM bearings are permitted. No hemispheric or similar type bearings are permitted. No spacers are permitted between the backing plate and bearings. The planet gear pin may be cut out to improve the removal of broken half shafts, the pin ends and all the planet gears must remain in place unless a spool is being used.

Gussets and modifications permitted on the rear axle, see Technical Diagrams in these Regulations, these are the only additional gussets allowed on rear axles, all pick-up points are to remain in the same dimensions, steel thickness and configurations supplied by 600 Racing (UK).



6.57 RIDE HEIGHT:

Restricting the rear axle movement in any way other than the 'stock' components is not permitted.

The car may have no less than 3½" between the bottom of the frame rails and the level ground without the Driver being in the car. The Licensed Eligibility Scrutineer will designate a location where ride height checks will be carried out and checks will not be made on any welded area.

6.58 RUNNING BOARDS:

The running boards must remain within the stock dimensions, steel thickness, location and configurations supplied by 600 Racing (UK) / 600 Racing UK's official parts supplier and may not be re-enforced in any way. The left-hand support bar has to be modified to allow the UK exhaust system to pass. The tubing of the rear two chassis mounting brackets can be cut back to allow the exhaust to pass with a nominal clearance and then must have a flat plate/bar welded to cover the cut tubing, bent to pass under the exhaust pipe and re-connected to the original chassis position with the currently supplied bolts and washers. The metal plate/bar used to re-connect the tube back to the chassis, will be the same steel dimensions and thickness as the flat bar/plate in the part as currently supplied. (See Technical Diagrams).

6.59 SHEET METAL:

The minimum thickness of sheet metal is .036". The rear deck (parcel shelf) shall be modified to remove the gaps between the bodywork & roll cage to provide a firewall, between the Drivers compartment and the fuel cell. In carrying out this modification the parcel shelf must not be moved from its original position, no part of the modifications to the shelf will show above the lower edge of the side and rear window apertures. A fuel cell access hole is permitted but must be totally sealed whilst the car is on the track.

6.60 SHOCKS:

All Legends Cars must use Bilstein (gas pressure single setting) shocks which will be tested using the 600 Racing (UK) Ltd / 600 Racing UK's official parts supplier supplied shock pressure gauge. The Bilstein shocks are stamped with the INEX logo and can only be supplied by 600 Racing (UK) / 600 Racing UK's official parts supplier. Shock Numbers or INEX marks and silver security stickers must be visible at all times. Changing or altering the fluid inside is illegal. Shocks may be turned upside down and or the upper part of the rear shock may be mounted on either side of the inside or outside of the frame. Shock bumpers are permitted.

6.61 SPINDLES / FRONT STUB AXLE:

The spindles (and pick-up points) must remain stock, with the stock dimension, steel thickness, location and configurations supplied by 600 Racing (UK) / 600 Racing UK's official parts supplier. The approved aluminium spindle supplied by 600 Racing (UK) / 600 Racing UK's official parts supplier must be installed by using the larger ball joint and upper arm; the spindle arm supplied by 600 Racing (UK) / 600 Racing UK's official parts supplier must have the INEX logo visible on top at all times. Damaged or bent spindles and pick-up points must be fixed by the beginning of the next race and with prior approval from the Scrutineer. Additional gussets, strengthening (including over welding) is not permitted.

6.62 SPRINGS:

All Legends Cars must use a 10" or smaller length spring. Any spring weight combination and aftermarket springs are acceptable. Only one spring is permitted per shock. Spring rubbers are not permitted.

6.63 SPROCKET ADAPTORS:

The sprocket adaptors must remain stock, within the stock dimensions, steel thickness, location and configurations of the original, supplied by 600 Racing (UK) / 600 Racing UK's official parts supplier. Set screws for the sprocket adaptor nut are permitted. Sprocket adaptor/prop. shaft bolts may be drilled for security wiring. Lightening the sprocket adaptor for weight savings in any way is illegal.

6.64 STEERING COLUMN:

The steering column may be modified for Driver comfort or safety, the universal joints may be upgraded and the final bearing (on the dash panel support bar) and its' position can be changed and a further bearing is permitted to support the column. The steering column bearing and its' stock or 600 Racing (UK) needle bearing bush in the lower firewall, must remain in its stock and currently supplied position. No shortening of threads is permitted if a rod end(s) type bearing(s) is/are used. Changing the spline in the steering rack is not permitted. A hose clamp is mandatory on the steering column in the engine compartment directly against the firewall (see Section 10). The



scrutineer's decision will be final, on the safety of any upgraded or standard steering linkage. The European collapsible column is acceptable supplied by 600 Racing (UK) / 600 Racing UK's official parts supplier.

No steering quickeners are permitted, without special written permission from 600 Racing (UK).

6.65 STEERING WHEELS:

Custom steering wheels are permitted, the scrutineer's decision on their safety will be final, all steering wheels have to be on steel quick release hubs.

6.66 SEATS:

Only 600 Racing (UK) approved seats may be used. In altering the seat position for safety and comfort the front seat mounting brackets (two of) may be modified. The modified mountings must still be welded to the floor seat mounting rail (this rail position cannot be changed). If the seat mountings are longer than the originals then they should be suitably re-enforced, or made of heavier material in proportion to their length. The rear seat mountings cannot be altered.

6.67 TYRES:

Competitors must use the MRF Legends Cars tyre. Tyres may not be soaked, softened, siped (razor cuts), grooved or re-capped (remoulded). No tyre at any time will be softer than the prescribed 56 points on a durometer. Tyre warmers and any other means of artificially warming tyres are prohibited.

At all times during an Event the tread depth must not reach the wear bar, damaged tyre sidewalls may not be repaired in any way.

It is prohibited to use traction compounds or any substance that might alter the physical properties of a tyre as supplied by the manufacturer. Tyre cleaners and shiners, tyre softeners, track adhesives, brake fluid, diesel fuel, etc. will not be permitted on tyres. The use of tyre heating/heat retention devices, tyre treatments and compounds is prohibited.

6.68 TRACTION CONTROL DEVICES:

No electronic or computerised wheel spin/traction control device(s) are permitted. Should any Driver be found to have a traction control device fitted to the car (whether operational or not) the Driver will forfeit all the Championship points earned to date and will not be eligible to earn any further points for the remainder of the season.

6.69 UPPER CONTROL ARMS:

The upper control arms must remain stock, within the stock dimensions (4¼" in length) steel thickness, location and configurations supplied by 600 Racing (UK) / 600 Racing UK's official parts supplier and may not be altered in any way. The tolerance on the measurement will be +/- 1/8" (0.125").

6.70 WEIGHT:

The minimum weight is (610kgs) when weighed with the Driver and in full racing condition after any practice or race. The Licensed Eligibility Scrutineer will designate the scales to be used for any post-race checks and they will be deemed to be the Championship scales.

6.71 WEIGHT SAVING MEASURES:

Lightening of 'Stock' components by shaving, milling, drilling or any other method is illegal. Any item on a Legends Car that is used (other than what is mentioned in the rules) as a weight saving method is considered illegal. All non-stock aluminium, titanium, stainless steel components are considered illegal.

6.72 WHEELS:

Only 600 Racing (UK) supplied wheels that have a 13" diameter, a 7" width and the offset of only 2¾" to within a +/- variance of 1/8" (2 5/8" to 2 7/8") is permitted. The minimum weight of a tyre and wheel must be at least 12.2 Kilos without additional steel, lead or wheel weights. All wheel weights must be the 'Stick on self-adhesive type' only and be covered with duct or metal tape. Wheel weights must be external and not added inside the tyre. Bleeder or relief valves are not permitted in the wheels. Should a new wheel be introduced it must carry the INEX logo and supplied by 600 Racing UK Ltd.

6.73 WHEEL BASE:



All cars must comply with a 73" + / - ¼ inch wheelbase no tolerance outside these dimensions. To facilitate this wheelbase the rear panhard rod may be connected to either side of the right-hand chassis pick-up point.

Measuring wheelbase: The measurement will be taken with the front and rear tyres on one side in line with each other. To determine this, the measuring tool straight edge, or line must touch three points. These points are the front of the rear tyre sidewall and the front and the rear of the front tyre sidewalls. The measurement is then taken from the front edge of the front wheel rim to the front edge of the rear wheel rim. The process is the same when measuring wheelbase on the opposite of the side of the car. Should a wheel rim be in such condition that it would not give an accurate measurement, the Competitor will be requested to change wheels for a suitable rim so the measurement can be taken.

6.74 WIDTH / HEIGHT / OFFSET:

The total overall width of the car front and rear may not exceed 60 inches. The car must be able to roll freely through a 60" wide gauge.

All cars must be under a maximum of 48" in overall height.

There must be a minimum of 6" between the inside edge of the rear brake drum and the rear frame rails. No wheel or axle spacers are permitted.

The maximum camber (negative or positive) on either front wheel, of a Legends car that will be permitted to race or practice with, is 4 (four degrees).

6.75 WINDSHIELDS:

It is recommended a mesh screen be used for safety reasons or A Lexan windshield is permitted in the front window only and must have sufficient holes or slots (minimum five 20mm holes) to conform with the waiver of J5.20.8 of the Motorsport UK Regulations.

7. ENGINES:

Competitors will be allowed four (4) engines if competing in all Events of the 2023 season, only the Yamaha XJR1250 may be used. Each engine must be recorded in the passport before being used (also must have been checked and sealed by one of the approved engine builders see 7.3). Remain sealed for the duration of the season and may be called for inspection by the Eligibility Scrutineer at any time. Failure to facilitate any such inspection, for whatever reason, will be penalised by the deduction of 600 Championship points.

Should more than four (4) engines be used the Competitor will start from pit lane for all races when a 5th engine is used this will apply to each engine over four (4). This rule will also apply to team cars. This rule will apply to all competing in both Championships.

For Competitors / cars racing in either the Legends Cars Championship or Legends Cars Elite Cup (not the complete season) then they will be allowed two (2) Yamaha XJR 1250 should a third (3rd) engine be used the Competitor will start from pit lane.

The passport is to be at each Event for Scrutineer checking and must be handed to the Eligibility Scrutineer, having been updated, before a scrutineering ticket can be issued. Should any Competitor race with an engine that has not been logged in the passport, the Competitor will have a 200-point deduction for that round and will start from pit lane for the remainder of the Event and for every subsequent race / Event the fourth engine is used. Following the awards on Sunday the passport is to be collected by the Driver or a representative. Note this is your responsibility.

7.1 GENERAL ENGINE SPECIFICATION RULES:

The engine must remain a factory-stock Yamaha XJR1250 sealed engine supplied by 600 Racing (UK) / 600 Racing UK's official parts supplier. Alternative engine types may only be used with written permission from 600 Racing (UK), their eligibility for the Championship is at the sole discretion of 600 Racing (UK).

All engines 1250 must have at all times the four central and two rear (nearest to the bulkhead) head nuts drilled for sealing by the Eligibility Scrutineer. Two holes must be drilled in each of the six nuts as close as to the top of the domed part of the nuts as possible. The holes must be 2mm or larger. An additional seal will be attached by Scrutineer to be registered on the passport. This seal must remain in place at all times, should there be a need to check shims or cams this can only be done under supervision of the licenced scrutineer. Gear boxes will also be sealed for the 2022 season.

7.2 CRANKING COMPRESSION: ENGINES

The cranking compression testing method is with all spark plugs removed, with throttle fully open and engine to be cranked between 10 and a maximum of 12 revolutions to determine the cranking compression value. Cranking compression value for the 1250 engines must not exceed 175lbs/sq. in (if 175lbs is exceeded the engine cannot be raced and must be returned to the engine builder for correction). The scrutineer may request a change of battery should the engine not turn over sufficiently

Only Yamaha (part no. 5EA11181100) or Cometic (part no. LC105X00X610 [steel C8285]) head gaskets are permitted.

7.3 XJ1250 SEALED ENGINE SPECIFICATIONS:

XJ1250 engines can only be supplied through 600 Racing (UK) in a factory sealed condition. Any brand-new engine can only be purchased through 600 Racing (UK) i.e. invoiced through 600 Racing (UK) / Handy Distribution and will be supplied with 600 Racing (UK) seals.

600 Racing (UK) approved sealed condition: Any engine which does not comply with the above, must be purchased with either; 600 Racing (UK) seals attached in accordance with the 2017 Regulations, The seal numbers must be submitted to 600 Racing for verification with the approved engine builder who originally built the engine, by means of the 600 Racing UK engine report document or if the engine has no seals, or non 600 Racing (UK) approved seals, the engine must have been previously used in a road bike and be submitted to one of the approved engine builders, who will strip and check the engine to ensure the engine, complies with the 2017 Regulations. If the engine complies, the approved engine builder will complete the 600 Racing (UK) report document.

PROCEDURE FOR EMERGENCY REPAIRS TO SEALED ENGINES AT RACE MEETINGS:

The Licensed Eligibility scrutineer must be informed and be present before any seals are disturbed / broken / cut. It is at the scrutineer's discretion if any repairs may be carried out. The scrutineer must remove the seals required.

Should the scrutineer be called away a replacement scrutineer / official must be called to replace him to oversee the repairs.



As parts are removed, they are to be marked (with scrutinising paint or tagged with a seal to ensure correct /same parts are refitted), once fitted seal / paint may be removed.

In the event of a replacement part being required, e.g. Camshaft this is to be marked and the scrutineer will list all new parts fitted to be referred to the approved / official engine builder for later inspection on re-sealing.

Any engine builders seal removed will be held by the scrutineer and will be replaced with temporary Motorsport UK seal for this race weekend only.

The engine will need to be re – inspected by the official / approved engine builder prior to the next round, and officially resealed. The cost of inspection, rebuilding and sealing to be paid by the Competitor.

If on inspection by the official / approved engine builder a discrepancy is found, all points scored with this engine with temporary seals will be forfeited plus an additional 200 points penalty.

All results will remain provisional until the engine has been declared legal.

Below is the list of the 600 Racing (UK) approved engine builders:

Treherne Engine Services:

10 St Andrews Drive, Daventry Northants, NN11 4NX

Contact: John Treherne Tel: 07568 510221

Heights Engineering:

Broad Lane, Heights, Delph, OL3 5TX

Contact: Michael Fancy Tel: 07801 336531

Colin Smart:

Cresta Racing, Auchendennan Farm, Alexandria, Dunbartonshire, G83 8RB

Contact: Colin Smart Tel: 07988 950135 Email: colinsmart1990@gmail.com

Simon Watson:

Unit 2, Chelmsford Road, Great Dunmow, CM6 1SH

Contact: Simon Watson Tel: 01371 876998

Paul O'Brien:

POB Racing, Glendaars Cottage, Daars North, Sallins, Kildare, Ireland W91 D4E8

Contact: Paul O'Brien Tel: 00353-87-2117777 Email: Paul@pobracing.com

600 Racing (UK) reserve the right to add or delete to the list of authorised engine builders at their discretion, such changes will be notified to Competitors by means of a technical bulletin.

The 1250 engine must remain sealed and may not be restored to a 1200 engine (the 1250 engine will have a serial number with P501E/ P502E/P503E/P506E/P508E/P514E/P515E engine number prefix only. Please note: P502E are not recognised as legal in the USA as this is a European engine serial No. The 1250 engine with the 1250 serial number can only be raced as a sealed engine. Repairs, overhauls or maintenance required that involves the seal(s) to be broken will only be carried out by a 600 Racing (UK) authorised engine builder.

The only modifications permitted to be made to the factory sealed 1250 engine are:

- a) Changing the carburettor jets.
- b) All stock carburettor adjusters may be used.
- c) Adjusting the valve shims.
- d) Installation of an aftermarket clutch and spring of original design or twin plating the original spring plate. (No aluminium clutch plates or slippers clutches are allowed.)
- e) Upper head oilers, heavy duty valve springs, and "Pinned" Camshafts are permitted only if installed by an authorized engine builder.
- f) Steel liners and Wiseco (Legends Edition) Pistons are permitted supplied by 600 Racing (UK) Ltd.



- g) A water-cooled Cylinder Conversion may be used by means of parts supplied by 600 Racing (UK) Ltd. This conversion must be fitted by a 600 Racing (UK) Ltd authorised engine builder.
- h) Oil pressure relief valves may be shimmed to increase oil pressure.

Apart from items A to E above and the fitting of any aftermarket connecting rod bolts absolutely nothing can be improved on the engine, this includes machining any component to a better tolerance than supplied as OME.

NOTE TO 600 RACING (UK) APPROVED XJR1250 ENGINE REBUILDER(S):

The objective of the approved engine rebuilder(s) is to repair or maintain the XJR1250 (sealed) in its' absolute 'stock' OEM condition. This will mean that no oversize pistons are allowed and therefore once a sleeve is worn or damaged it must be re-placed with the standard size Yamaha part. Or 600 Racing (UK) / 600 Racing UK's official parts supplier supplied wiseco 0.004 or 0.008 oversized pistons.

Any rebuilt or repaired XJR1250 (sealed) that is found to have a performance advantage over a 'stock' engine of this type may lead to the approval of the engine builder being withdrawn by 600 Racing (UK) and a 12 month ban to the Competitor of entering a 600 Racing (UK) sanctioned Legends Car Events.

- 7.3.1 Only Camshaft Yamaha part No 5EA-12171-00 (inlet) and 5EA-12181-00 (exhaust) are allowed. Both cam timing dots must be visible in cam cap window at TDC. The only camshaft timing wheels permitted are for the carburettor specification camshaft, cam wheels from injection shafts are not allowed.
- 7.3.2 No slotting, oversize drilling of cam gear boltholes, only cam bolts part no 90105-06424 may be used.

Camshaft lobe dimensions

- Intake A: 35.950-36.050 mm Limit 35.850 mm
- Intake B: 28.058-28.158 mm
- Exhaust A: 35.950-36.050 Limit 35.850 mm
- Exhaust B: 28.045-28.145 mm

Degree Manufacturers Tolerance

0	8.04	8.04
5	7.95	7.99
10	7.69	7.87
15	7.40	7.61
30	5.79	6.05
45	3.40	3.64
60	0.66	0.84
75	0.20	0.26
90	0.05	0.09
105	0	0

- 7.3.3 Cylinder deck to piston heights must be a minimum of 0.013 thou, with a nominal cylinder height 3.475 inches. In conjunction with a Standard Yamaha steel base gasket part no 5EA-11351-00 (0.010 thou thickness gasket) or a Cometic Copper base gasket (0.005 to 0.020 thou thickness gasket) will give the required piston to achieve minimum deck clearance. Bore and Stroke, 79.0 x 63.8 mm displacement 1251 cm3. Cylinder deck to position height will be measured with the cylinder clamped in position.
- 7.3.4 Only standard Yamaha pistons Part no 5EA-11351-00 or legends edition Wiseco pistons up to 0.008 thou oversize are permitted.
- 7.3.5 Only standard Yamaha or Wiseco piston rings may be used. No Total Seal piston rings are allowed.
- 7.3.6 The only permitted Machining of the valve seats angles are;
75-60-45-15, 70-60-45-30, 60-45-30, 60-45-15.
The seat width min 0.030 thou.

Valve head diameter (intake) 28.90-29.10mm, (exhaust) 24.90-25.10 mm

Valve face width (intake) 1.980-2.550 mm, (exhaust) 1.980-2.550 mm

Valve seat width (intake) 0.90-1.10 mm, (exhaust) 0.90-1.10 mm

Valve stem diameter (intake) 5.475-5.490 mm, Limit 5.445 mm

Valve stem diameter (exhaust) 5.460-5.475 mm, Limit 5.430 mm

Valve guide inside diameter (intake) 5.500-5.512, Limit 5.552 mm

Valve guide inside diameter (exhaust) 5.500-5.512 mm, Limit 5.552 mm

Valve stem to valve guide clearance (intake) 0.010-0.037 mm, Limit 0.080 mm

Valve stem to valve guide clearance (exhaust) 0.025-0.052 mm, Limit 0.100 mm

Valve stem runout 0.010 mm

7.3.7 No enlarging of the seat inside throat diameter.

7.3.8 Valve face angle must be 45 degrees, no back cutting, the valve must remain standard, Yamaha part no 36y- 12111-00 and 36y-12121-00.

7.3.9 Heavy duty valve springs may be used with a max installed pressure 68lbs

7.3.10 Only XJ series heads may be used. (No fj series heads)

7.3.11 Cylinder head resurfacing is allowed, but additional Base gaskets will be required to ensure that a compression ratio of 10:1 is not exceeded.

7.3.12 Cylinder head CC in standard form is 33.2cc to 34.2cc any variance below this will require additional gaskets be fitted.

7.3.13 Internal components cannot be polished, Bead blasted, Shot peened.

7.3.14 All other components to be stock Yamaha parts.

7.3.15 An alternative to heavy duty cylinder head studs is permitted by way of an "inverted top hat" insert and non-stock cylinder head nut

7.3.16 The stock I.D.at the bottom 1/16 (one sixteenth) of the valve seat insert is 0.990" for the intake port and 0.830" for the exhaust port. No port alterations of the intake or exhaust below the seat are permitted.

7.3.17 CAMSHAFTS:

The cam shaft (one intake and one exhaust) must remain as stock Yamaha as and in the same location supplied by 600 Racing (UK). The camshaft marking 'I' (Intake) and 'E' (Exhaust) may not be removed, and must remain in their appropriate positions. Stress relieving by machining or polishing on the radius next to the cam gear or on the shaft is permitted (see Section 10 for drawing). Modifying any part of the lobes (lift, profile, duration, weight etc.) is illegal. Aftermarket overhead oiling systems for the camshafts are permitted. Steel billet intake cams are not permitted. Installation of a ¼" ID x ½" OD piece of 4130 aircraft steel the full length of the camshaft is permitted. Note: This modification must be carried out in a very specific manner. Please contact 600 Racing (UK) for details.

7.3.18 CARBURETTORS:

Unless otherwise specifically stated within these Regulations only the original stock components supplied & intended for XJ 1250 engines are allowed.

- a) Changing the carburettor jets is allowed
- b) All stock carburettor adjusters may be used
- c) Changing the main jets, idle jets and air corrector jets is allowed.
- d) Changing the piston spring and metering needle is allowed.
- e) The emulsion tube cannot be modified in any way and must remain as standard.
- f) Material cannot be removed from any part of the carburettor body piston.

The above applies to all 1250 carburettors.

7.3.19 CAM CHAIN:

The cam chain must remain as stock Yamaha XJR1250 supplied by 600 Racing (UK).

7.3.20 CAM CHAIN ADJUSTERS:

Aftermarket manual cam chain adjusters are not permitted.

7.3.21 CLUTCH:

The clutch (plates and springs) may be replaced with any aftermarket type of the same design (no aluminium or titanium clutch plates). Twin plating the original spring diaphragm plate is permitted and recommended.

7.3.22 CYLINDER HEAD:

A combustion chamber may be repaired by welding and grinding back to the official 'stock' configuration of the combustion chamber. An alternative to heavy duty cylinder head studs is permitted by way of an "inverted top hat" insert and non-stock cylinder head nut (not permitted for World Final INEX Events).

7.3.23 CRANK SHAFT:

The crank shaft must remain stock XJR1250 supplied by 600 Racing (UK) / 600 Racing UK's official parts supplier, Modifying the throw balances or weight of the crank is illegal.

7.3.24 RODS (CONNECTING):

The rods must remain in stock for the XJR1250 delivered by 600 Racing (UK).

7.3.25 TRANSMISSIONS & GEARSHIFT MECHANISM:

The transmission and transmission gears must remain stock Yamaha XJR1250(sealed) supplied by 600 Racing (UK). They may not be lightened in any way. The transmission gears may be shimmed only for the purpose of proper engagement. Standard and aftermarket shims may be used. The gear shift mechanism must remain as a "stock" part and in original position / location and configuration supplied by 600 Racing (UK) / 600 Racing UK's official parts supplier. Needle bearings are not allowed.

The gear shift lever and link rod must be as per the 'stock' part. The aluminium clamped lever on the splined shaft from the engine may be changed for the steel splined Yamaha part supplied by 600 Racing (UK) / 600 Racing UK's official parts supplier and modified for length. The 'Triangle' may have a welded boss/bush added to minimise play in this component Needle bearings are not permitted.

REVERSE GEARS:

All Legends Cars must be fitted with a reverse gear that is in operational order at all times. Only a 600 Racing (UK) supplied reverse box mechanism running a one-to-one forward drive is acceptable no other system is allowed. The original location, metal thickness, dimensions, configurations and ratio of all components and parts supplied with the mechanism cannot be altered in any way, any weight saving measures on these components will be considered illegal. Eligibility Scrutineering will apply and component sealing will take place. Only 600 Racing upper and lower brackets can be used for installation of the reverse system. The plate can be welded in position but cannot allow the gearbox to stand more than 7mm above the 5 x 2.5cm bottom bar.

7.3.26 VALVES:

Only Yamaha XJR1250 valves are permitted. No modifications are permitted to the valves.

7.3.27 VALVE GUIDES:

The valve guides must remain the same size, length and location (see Section 10 for drawing). The guides may not be altered in any way. Shotpeening of valve guides is not permitted. Brass aftermarket valve guides of the same dimension of stock may be used.

7.3.28 VALVE SPRINGS:

The valve springs may be replaced with aftermarket steel springs. Only stock steel valve spring retainers and clips/keepers are permitted. No titanium or other lightweight alloys are permitted.

8. APPENDICES

The following Commercial Regulations are “contractual” between the Entrant and / or Driver and the Organisers and / or Promoters and are not considered by Motorsport UK. Accordingly, the application of these Commercial Regulations by the Organisers and / or Promoters will not be subject to the Judicial processes of either the Championship Stewards and / or the Motorsport UK / MSC.

8.1 RACE ORGANISING CLUBS AND CONTACTS:

BARC, Thruxton Circuit, Andover, Hampshire. SP11 8PN

Tel: 01264 882200

Fax: 01264 882233

E-mail: competitions@barc.net

600 Racing (UK) Ltd, PO Box 209, Cranleigh, Surrey, GU6 9BR

Name: Phil Cooper

Tel: 07983 596607

Email: phil@legendsracingeurope.com

Eligibility Scrutineer:

Name: Richard Williams

Tel: 07760 412792

Email: rich.t.williams@btinternet.com

8.2 COMMERCIAL UNDERTAKINGS:

Drivers must hold a valid ‘racing membership’ of the BARC and be registered for the Championship. Membership of INEX is included within the Championship registration fee.

TRADE SUPPORT VEHICLE DECALS & OVERALL PATCHES:

No colour restrictions are applied. Competitors are encouraged to produce imaginative and distinctive colour schemes that will add to the spectacle of Legends Cars racing so long as these are well maintained and cars presented at race circuits to a standard acceptable to 600 Racing (UK).

Competitors may display any sponsors names, graphics or trademarks except those that are of companies, organisations or products in competition to the main or subsidiary sponsors of the Championship which shall not be displayed on the car in any manner.

The display of the Competitor’s own graphics, sponsors names or trademarks must be within the reasonable boundaries of good taste for which 600 Racing (UK) will be the final arbiter. The display of tobacco advertising on anything associated with Legends Cars is prohibited.

The Competitors will be deemed to have undertaken responsibility for the display of the obligatory Championship Decals, outlined in Section 8.6 by registering for this Championship. Failure to comply with these requirements may lead to ineligibility and consequences under Section 4 of these Championship Regulations.

The use of the Legends Cars trademark is reserved for Competition Legend Cars, Drivers and mechanics overalls and competition vehicles only. The trademark may not be used on any items offered for sale or used outside of the applications outlined above without the express written permission of 600 Racing (UK).

Space will be allocated to Competitors by 600 Racing (UK) Ltd within the area provided for Legends Cars by the organising club or circuit. The area provided to each Competitor will be in accordance with a layout plan published in advance of the race meeting by 600 Racing (UK) or as directed by 600 Racing (UK) on the day. All Legends Cars must park and be kept in this area when not racing and should not be taken elsewhere to be displayed or worked upon without the permission of the 600 Racing (UK) official in charge of the Legends paddock area. No other cars are permitted in the Legends Cars paddock any parking of private cars/vans etc., in the restricted Paddock area will carry a 50 point each deduction for that Race Day.

Failure to adhere to this condition may result in the withholding of points and prizes.

8.3 PROMOTIONAL ACTIVITIES:

Drivers and Teams will hold themselves available to support any ‘on-circuit’ promotional activity for which the organising club and/or the Championship Sponsor and/or 600 Racing (UK) have given reasonable advance notice.



In consideration of entering into any Event sanctioned by 600 Racing (UK), car owners, sponsors, Drivers, pit-crews or agents, agree to permit 600 Racing (UK) and its assigned, the use of names and pictures and pictures of the car for advertising and publicity both before and after any Event, and to relinquish all rights to any photographs or video recordings taken in conjunction with any Event and give their permission to publish or sell the same.

8.4 VEHICLE PRESENTATION:

The presentation of the car is fundamental to the profile of the Championship, its sponsors and its audience. Therefore, in considering whether to permit any car to race, at any point during the season, the organisers will regard as paramount the presentation of the car. In taking into account its appearance inherent in which is the standard of its presentation (including interior) they may disbar any car which they consider may prejudice the reputation of the Championship/series or is otherwise unacceptable.

This will include where the car is presented at a race Event bearing accident damage sustained at a previous Event and which has not been subject to the completion of a full and proper repair. Note: A double header can be regarded as one Event for the purposes of this Regulation.

8.5 ON BOARD CAMERAS:

It is mandatory to fit at least one forward-facing camera to the vehicle, additional cameras can be fitted, and all camera fitments must be approved by the Scrutineer. Any footage obtained must not be used for commercial use and the Clerk of the Course and the Stewards may make use (including copies) of any footage recorded during an Event to assist in reaching their decisions on any judicial matters. All camera fitted must record footage at a minimum of 720p resolutions.

It is mandatory that all cameras fitted to the vehicle must be in fully working order and must record the entirety of all official sessions. Once a session has finished and all vehicles have been released from park fermé, Competitors are permitted to stop their cameras recording and view the footage. No footage may be deleted until all investigations by the Clerk of the Course and the Stewards have been completed.

Post session a member of 600 Racing/TV/ Media Support staff may request a copy of your footage for TV purposes.

8.6 COMPETITION NUMBERS / DECALS / LIVERY:

There must be of 30cm high x 10cm stroke on the centre of both doors and 45cm height x15cm stroke on the roof (with the base of the number towards the right side of the car i.e. the opposite side to the Driver's door). The number must also be displayed on the front right wing / fender facing forward with a minimum height of 20cms and on both rear wings / fenders 15cm high. They may be of any colour but must be in contrast with the surrounding body colour and clearly distinguishable. Consideration must be given at all times, to the positive identification of cars by competition organisers, whose decisions will be final.

To keep Legends Cars in-keeping with other forms of UK circuit racing, no car must use oval style graphics or number. If unsure, entrant must seek font approval from 600 Racing (UK) prior to graphics being produced.

The following are reserved area requirements for Championship Decals:

ON THE CAR	
Main Championship Sponsor:	As a minimum the area immediately above the windscreen. (18" x 6") 46 x 15 cm is reserved, plus front fender Driver left and both rear fenders stickers of 6" diameter. There is a main Championship sponsor specified, this area is reserved as above and free from other logos.
TV Sponsor:	The sun visor area is reserved for the TV sponsor. Carbon fibre is not to be used in this area.
Other Championship Sponsor:	A space for one decal on both sides of the car for each subsidiary sponsor (decals each measuring 20sq. inches maximum and not exceeding 6" in length).
Legends Cars Logo:	MANDATORY: A space for one 5 ½" or 15 cm (min) logo on either side of the car in front of the rear wheel arch and immediately above the rear wheel arch line and immediately above the rear nerf bars uprights.
BARC Logo:	MANDATORY: One logo on either side of the car on the engine panel, just below the bonnet, this panel is just in front of the door.
ON THE RACE SUIT	
Main Championship Sponsor:	A patch not exceeding 8 sq. inches, on the upper chest immediately below the neck line.

Other Sponsor:	(If different from the main Championship sponsor) a patch not exceeding 8 sq. inches on the upper chest immediately below the neck line second only in prominence to that of the main Championship sponsor.
Legends Cars Logo:	A patch not exceeding 8 sq. inches on the upper front body.

600 Racing (UK) Ltd will supply Championship Decals but number decals are the responsibility of the registered Driver.

8.7 PARTS LIST:

All parts below must carry a silver security sticker at all times.

LC1012	Exhaust Can	LC110X00X155	Nerf Bar Sedan – Left
LC1014	Reverse Gear Box	LC110X00X156	Nerf Bar Sedan – Right
LC1022	Reverse Gearbox Bracket Top	LC110X00X250	Steering Column Assembly
LC1022A	Reverse Gearbox Bracket Bottom	LC110X00X251	Lower 2/3 Steering Column Assembly
LC1057	Fibreglass Dash	LC110X00X254	Upper Steering Column Shaft
LC105X00X100	Air Duct Ignition Coil Mount	LC110X00X261	Steering Rack
LC105X00X104	Bumper Air Scoop F/Glass	LC115X00X021	Running Board Left
LC105X00X105	Fender Scoop Air Duct F/Glass	LC115X00X022	Running Board Right
LC105X00X110	Engine Air Duct Lower Alum Chevy	LC120A01A040	Hood 37 Chevy
LC105X00X206	Right Side Motor Mount	LC120A01X031	Grill 37 Chevy Painted
LC105X00X207	AZ-D Left Side Motor Mount	LC120A10A000	Body 37 Chevy Sedan Left
LC105X00X208	Ignition Coil Mounting Plate	LC120A11A020	Fender Left Front 37 White
LC105X00X213	Ignition D Box Red	LC120A20A000	Body 37 Chevy Sedan Right
LC105X00X215	Ignition Coils Inex Approved	LC120A21A020	Fender Right Front 37 Chevy White
LC105X00X217	Sprocket Adapter	LC120B01A040	Hood 37 Ford White
LC105X00X303	Oil Cooler Bracket	LC120B10A000	Body 37 Ford SD Left White
LC1100	Rear Prop Shaft Short	LC120B11A020	Fender Left Front 37 Ford White
LC1101	Front Prop Shaft Long	LC120B12A020	Fender Left Rear White
LC110X00X120	Front Bumper Painted – 600 Racing	LC120B20A000	Body 37 Ford SD Right White
LC110X00X121	Rear Bumper Painted – 600 Racing	LC120B21A020	Fender Right Front 37 Ford
LC110X00X150	Nerf Upright PC – Left Short	LC120B22A020	Fender Right Rear White
LC120E11A020	Fender Left Front 34 Ford	LC120C02A010	Deck Lid 37 Chevy
LC120E12A020	Fender Left Rear 34 Ford	LC120E00A000	Body 34 Ford CP Comp White
LC120E21A020	Fender Front Right 34 Ford	LC120E01A030	Grill Nose 34 Ford White
LC120E22A020	Fender Rear Right 34 Ford	LC120E01A040	Hood 34 Ford White
LC120G02A010	Deck Lid 34 Coupe	LC120E01X031	Grill 34 Ford Painted
LC120H01A030	Grill Nose 37 Dodge	LC120E02A010	Desk Lid-34 Ford CP-White
LC120H01A040	Hood – 37 Dodge White	LC125X00X022	RR Rear Trailing Arm 12 Alum”
LC120M02A010	Desk Lid – Sedan White	LC125X00X023	RR Upper Rear Link 6.5 Alum
LC120X003440	Fender Bracket AZ-40 40/34F	LC135X00X100	Bassett Wheel Black
LC120X00C037	Fender Bracket AZ-H Chevy	LC135X00X101	Bassett Wheel Silver
LC120X00F037	Fender Bracket AZ-1 37 Ford	LC135X00X102	Chrome Plated Trap Wheel
LC125X00X002	Lower A-Arm Left	LC135X00X110	Black Elegant Trap Wheel
LC125X00X003	Lower A-Arm Right	LC140X02X005	Axel Housing Double Shear
LC125X00X020	RR Panhard Bar 23.5	LC490V01X002	Thunder Upper Arm Assembly
LC125X00X021	RR Tie Rod Strut Arm 11 Alum”	LC925X00X114	Legends Shock
LC110X00X151	Nerf Upright PC – Right Short	LC925X00X204	Spindle Arm
LC110X00X152	Nerf Upright PC – Long	LC925X00X206	Spindle Base
LC110X00X153	Nerf Bar Coupe – Left	LC955X00X013	Fuel Pump 3#
LC110X00X154	Nerf Bar Coupe – Right		

9. DIAGRAMS

DEPICTING EITHER MANDATORY OR OPTIONAL ADDITIONS TO FRAME OR COMPONENTS.

9.1 DOOR PLATES:

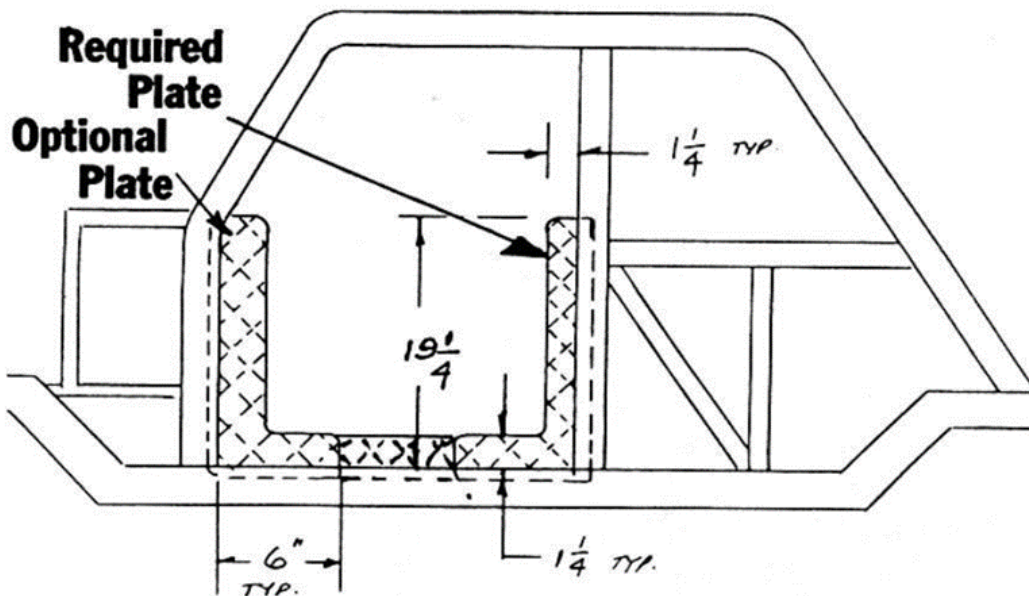
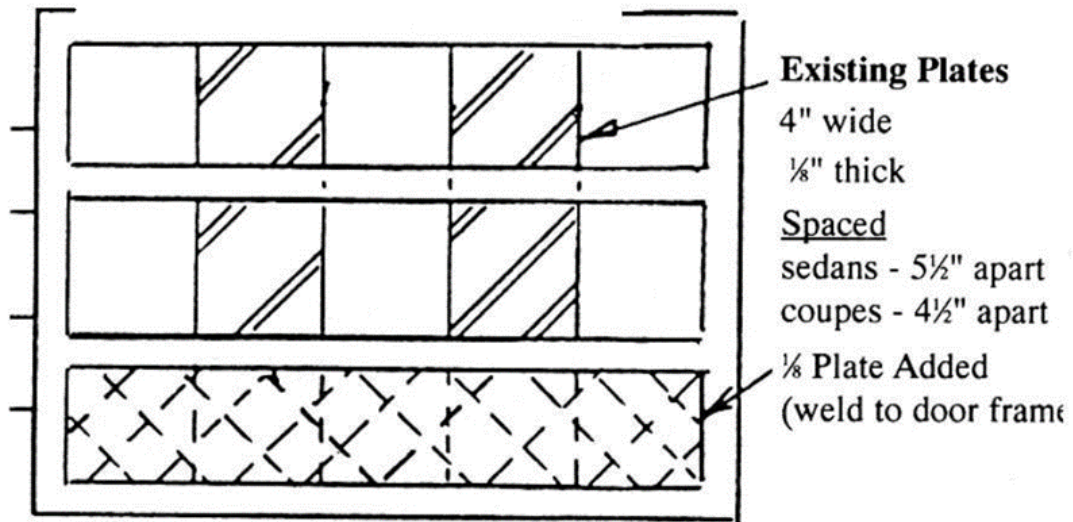

9.2 MANDATORY ROOF BRACES:

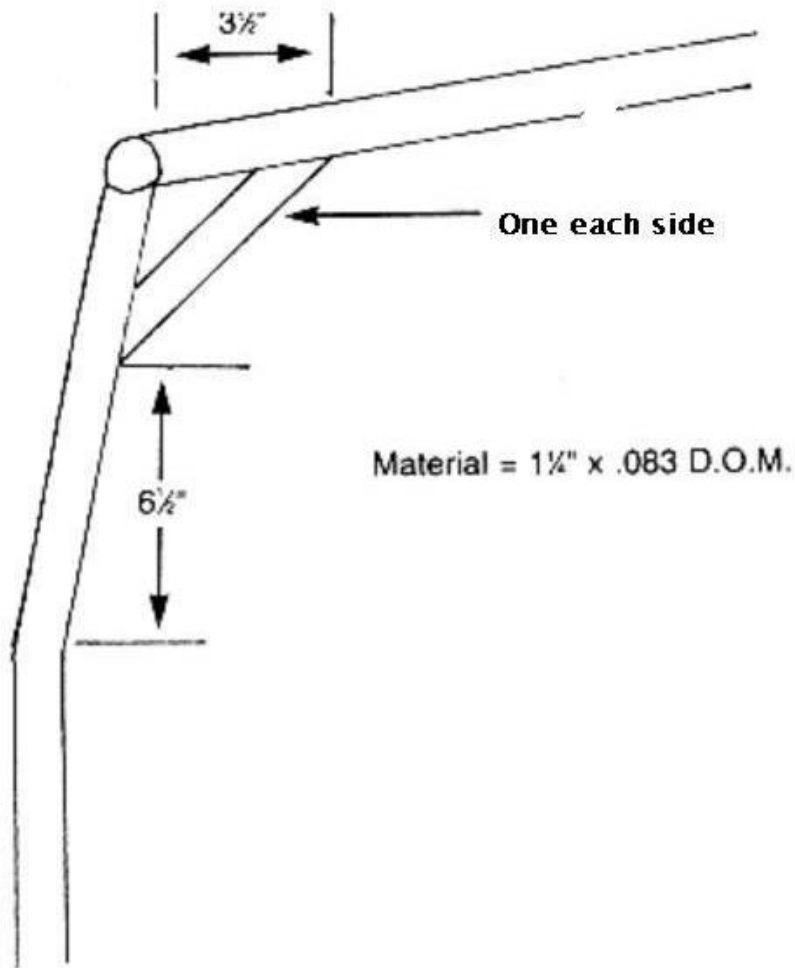

9.3 OPTIONAL ADDITIONAL FRONT PLATE:

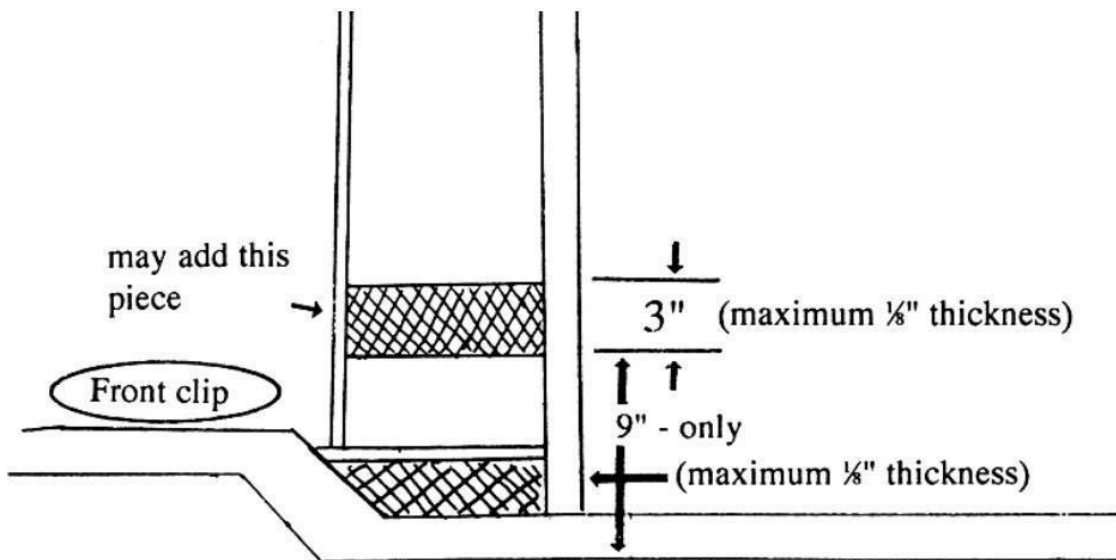

9.4 OPTIONAL ADDITIONAL REAR GUSSETS:

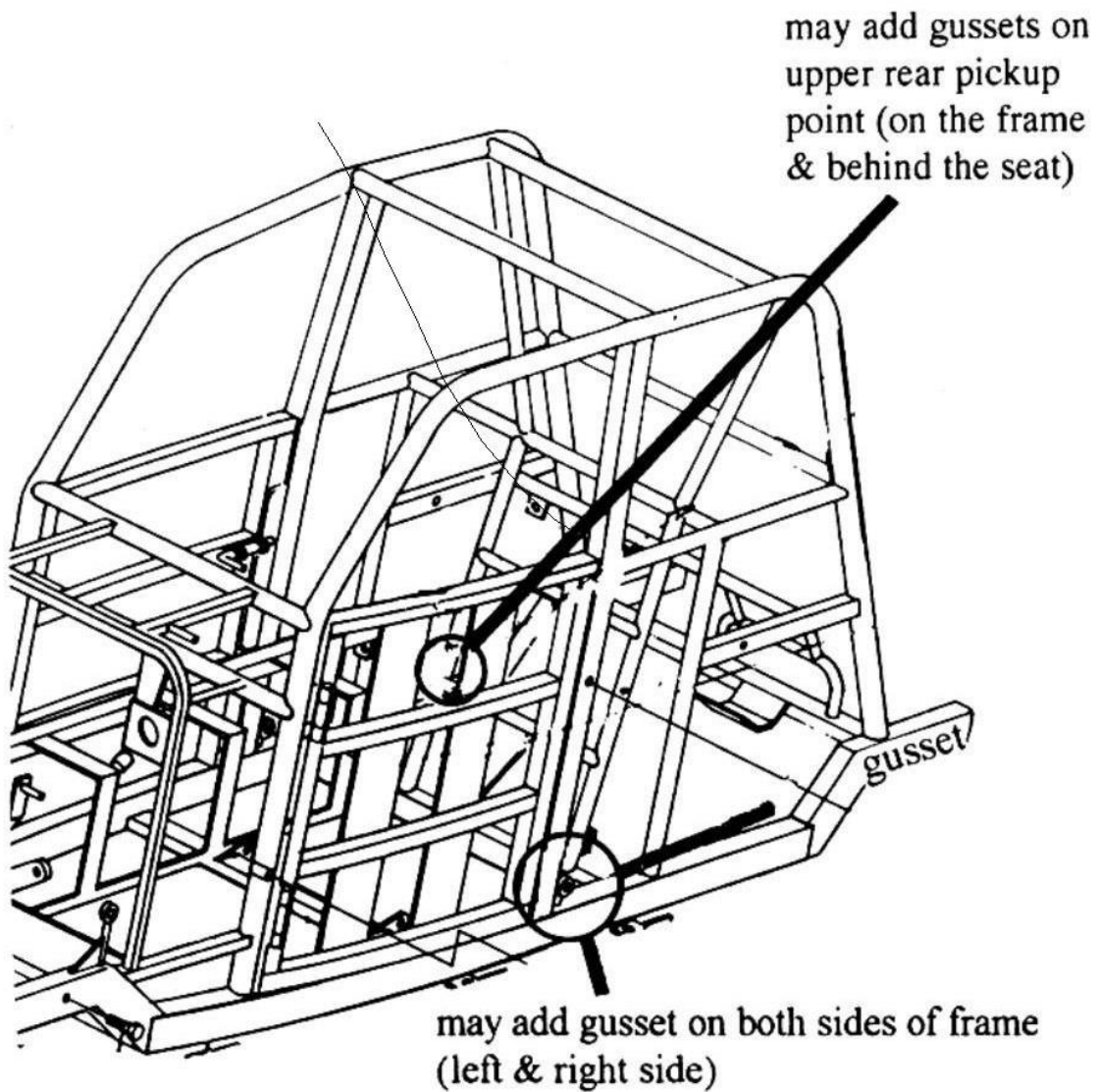

9.5 FRONT CLIP – PERMITTED GUSSET REINFORCEMENT:

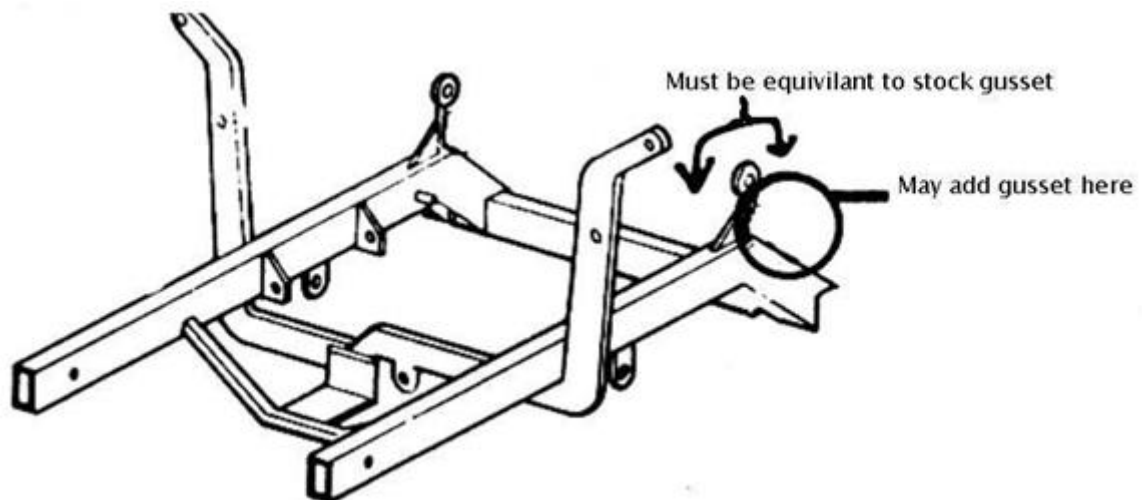

9.6 REAR AXLE

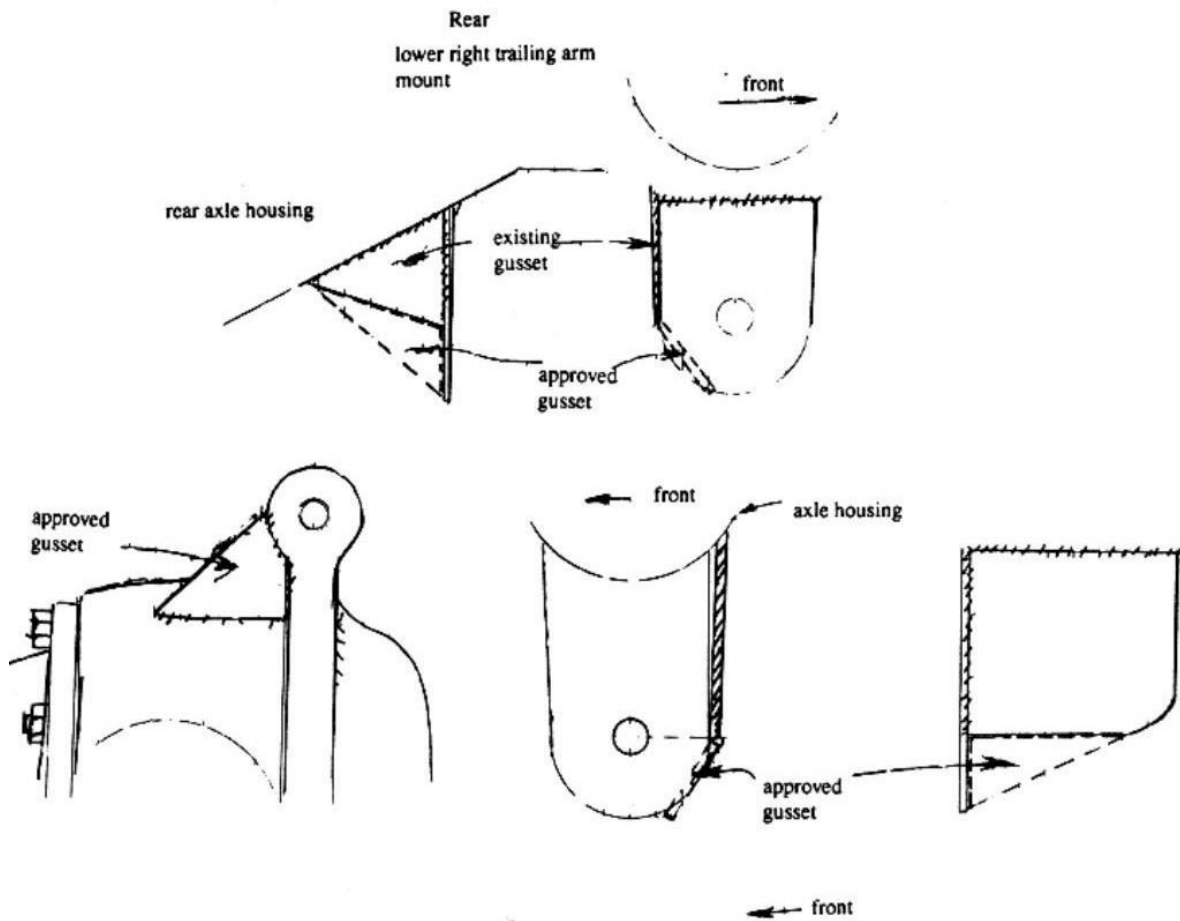

9.7 STEERING RACK PLATE

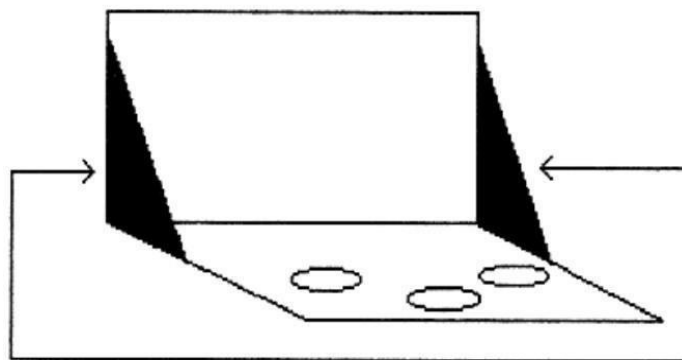

Approved Additional Gussets

(1/8" Max. Thickness Gusset)

9.8 DOOR PLATES

MANDATORY
STEERING COLUMN CLAMP
& ADDITIONAL REAR STRUT

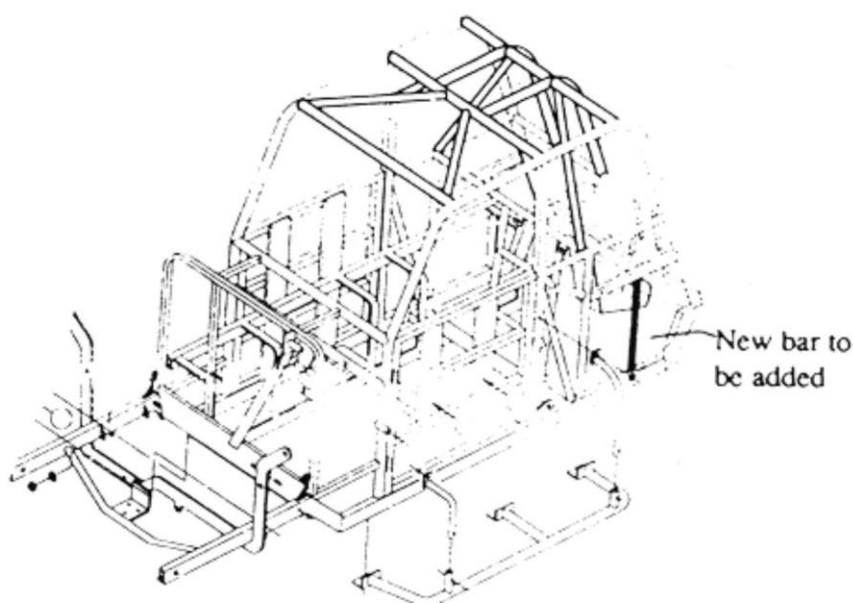
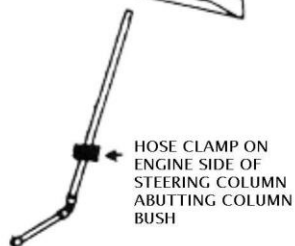
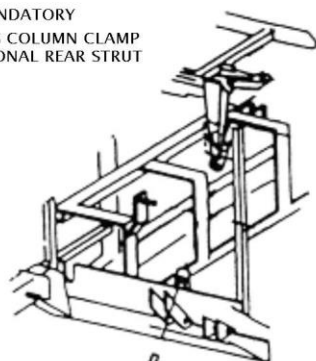

9.9 ADDITIONAL REINFORCEMENT REAR AXLE:

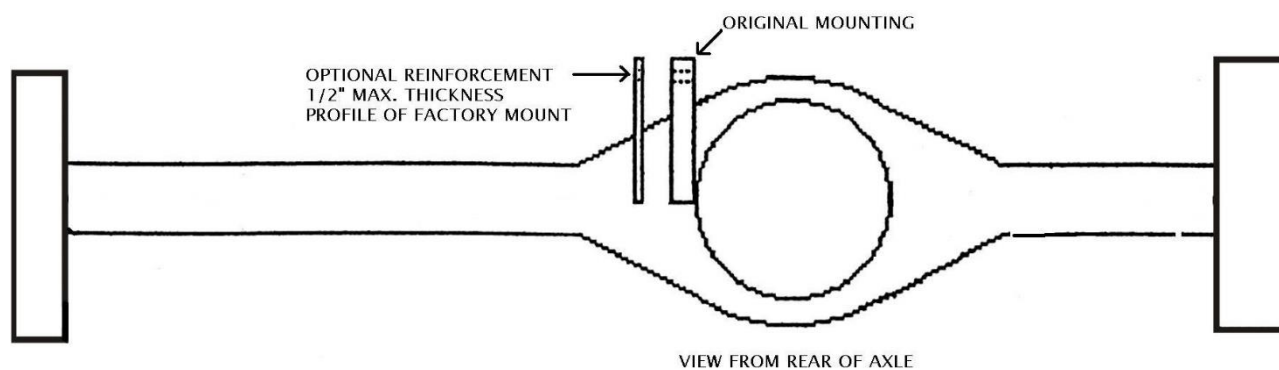

THE FOLLOWING DIAGRAMS ARE STOCK SPECIFICATIONS OF SOME COMPONENTS OF LEGENDS CARS.

LEGENDS & THUNDER ROADSTER REAR END HOUSING

SPECIFICATION FOR INFORMATION ONLY

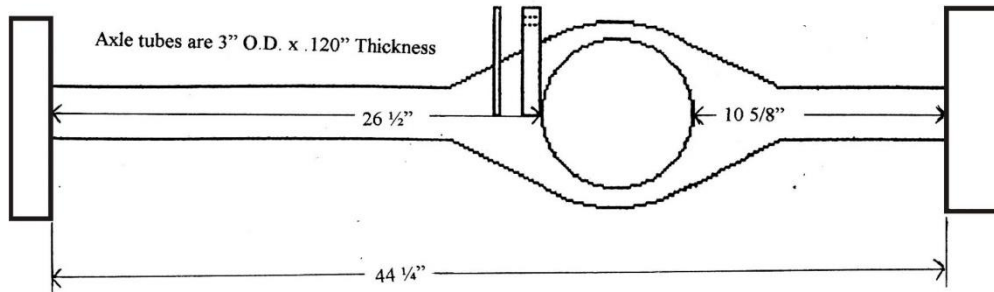

LEGENDS SHOCK TOWER

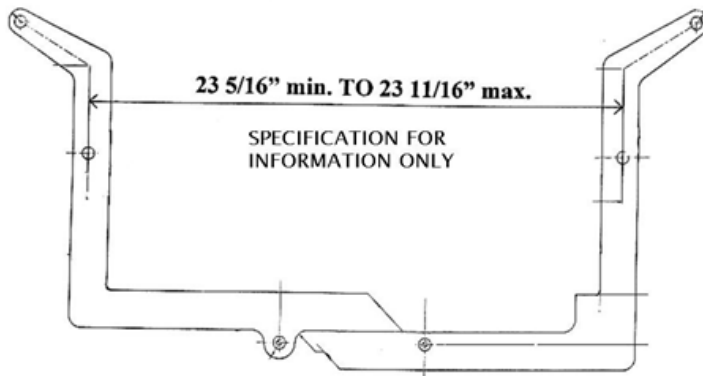

LEGENDS LEFT SIDE MOTOR MOUNT PICKUP POINTS & FRONT CLIP MEASUREMENTS

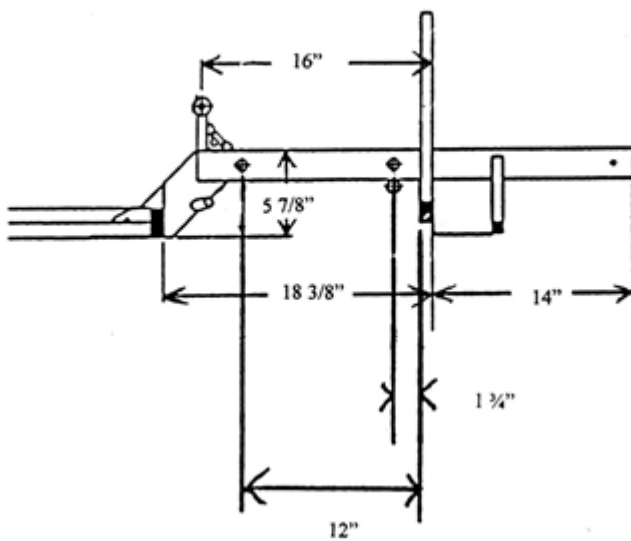

LEGENDS RIGHT SIDE MOTOR MOUNT

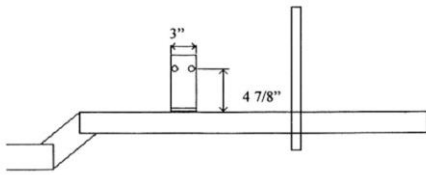

NOTE: ALUMINUM MOUNTS OR EXTRA HOLES ARE ILLEGAL

LEGENDS FRONT & REAR BUMPER

(1" STEEL TUBE) (8 lb. MAX. WEIGHT)

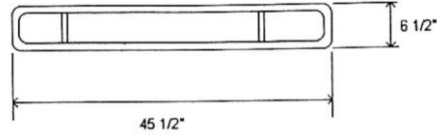

LEGENDS RIGHT & LEFT NERF BARS

(WEIGHT = 4 lbs. MAX.)



LEGENDS & THUNDER ROADSTER SPROCKET ADAPTER

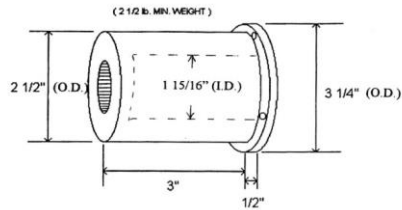

LEGENDS & THUNDER ROADSTER AXLES

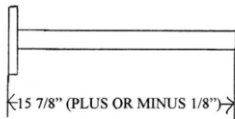
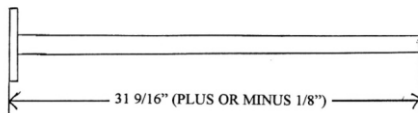

LEGENDS & THUNDER ROADSTER SPINDLE, LEFT & RIGHT

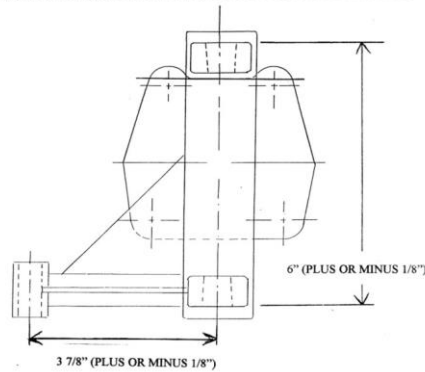

LEGENDS UPPER CONTROL ARM FRONT MOUNTING POINT

SPECIFICATION FOR INFORMATION ONLY

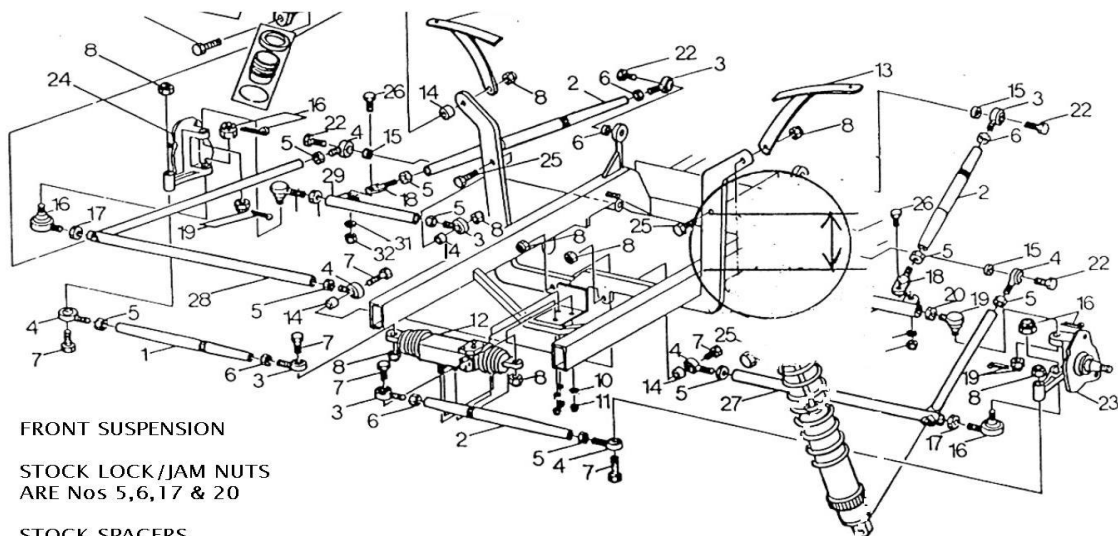

FRONT SUSPENSION

STOCK LOCK/JAM NUTS
ARE Nos 5,6,17 & 20

STOCK SPACERS
ARE Nos 14 & 15

DISTANCE OF PICK-UP POINT TO TOP OF FRAME
3 5/8" +/- 1/8" TO CENTRE LINE OF HOLE

LEGENDS SUSPENSION PICKUP POINTS

SPECIFICATION FOR INFORMATION ONLY

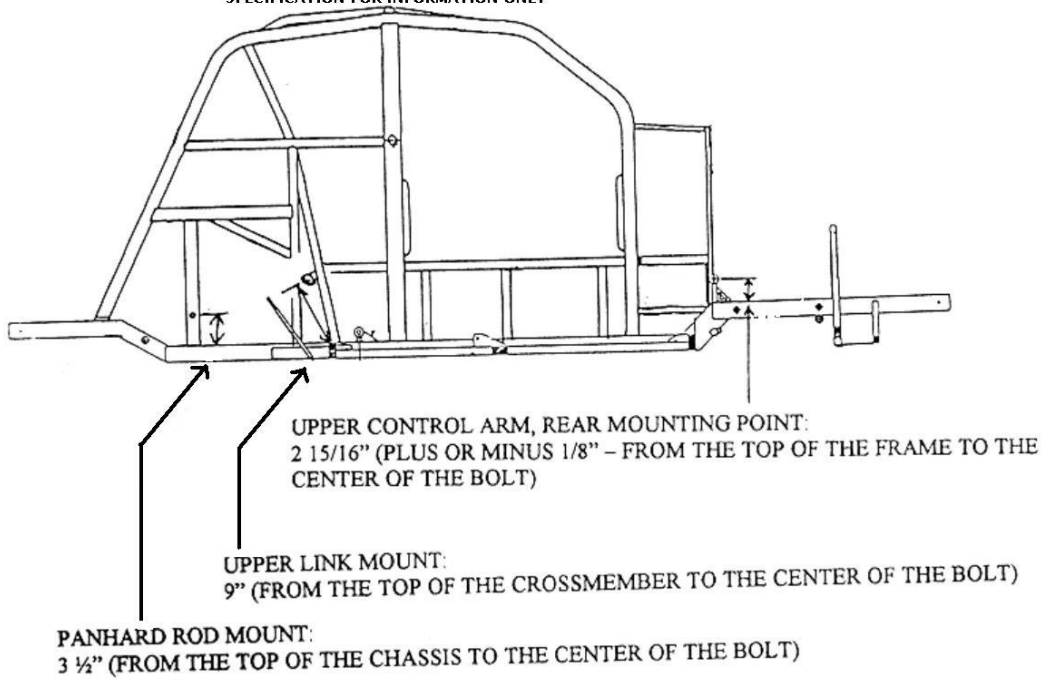

LEGENDS LEFT SIDE MOTOR MOUNT

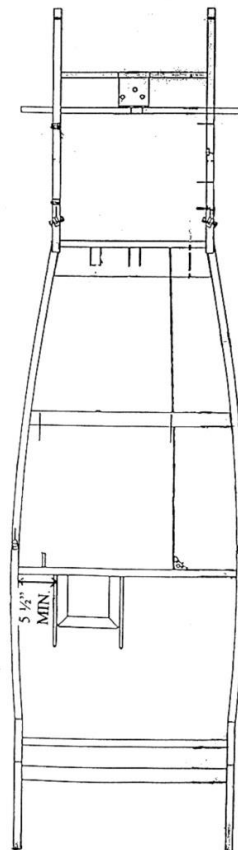
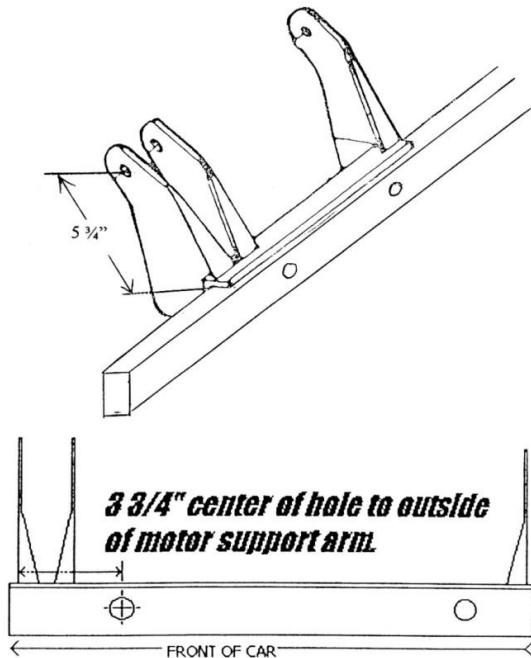

Note: The measurement for the battery box offset will be taken at the point closest to the crossmember, from the inside of the framrail to the outside of the battery box.

STOCK YAMAHA CAMSHAFT

STRESS RELIEVING THE CAMSHAFTS

INEX has approved polishing the shaft of the cam in these areas (for stress relieving purposes only).

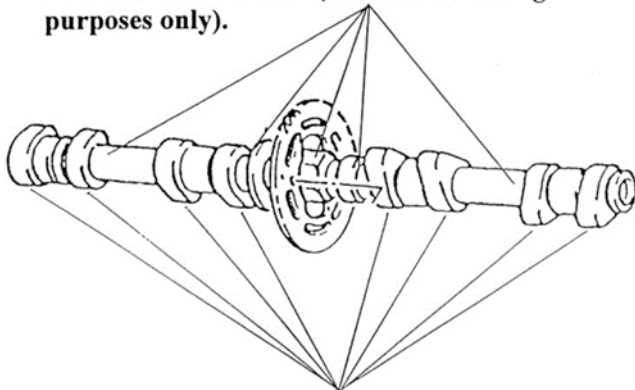

You may not alter the cam lobe in any way.
(The sides of the cam lobe must remain untouched, with casting marks on them).



34 coupe firewall to lower rear cross bar
From the fire wall to rear cross bar 44 in



34 coupe. Rear cross to b- post
Rear cross to b-post is 8in



Seat back bar from b-post is 12 in



13in from upper link to petrol tank bar



Reference 6.24



A socially-minded standard of behaviour is expected from everyone within the motorsport community.

By participating in a Motorsport UK Event in any capacity you agree to follow the values of the Respect Code:

Motorsportuk.org/racewithrespect
#RaceWithRespect

The Values

- **Respect**
- **Fair play**
- **Integrity**
- **Good Manners**
- **Self-Control**

I pledge to #RaceWithRespect and:

- Contribute to a welcoming and friendly environment that ensures the safety and welfare of all participants.
- Always behave with integrity and uphold fairness in the sport; play my part in keeping the sport safe through my actions
- Treat everyone with respect, regardless of their gender, ethnic or social background, language, religious or other beliefs, disability, sexual identity or other status
- Recognise that we all represent the sport and therefore have a duty to be polite and respectful to all staff, officials, fellow Competitors, volunteers, as well as fans and supporters
- Respect the rules, Regulations and authority of the officials and Motorsport UK

Any breach of these obligations may result in disciplinary action.