



Championship Bulletin 2025

British Truck Racing Championship

Bulletin Number	01
Date of Implementation:	8 th April 2025
Championship Permit No:	CH2025/R004

The following regulation amendments are made to correct errors (either in detail or administration of changes) and are made with immediate effect.

All deletions are shown in ~~blue strikethrough~~, and additions are show in red underline. Notes are included in *italics*.

1.1 TITLE & JURISDICTION

Motorsport UK Championship Permit No: CH2025~~4~~/R004 (A)

5.4 GENERAL TECHNICAL REQUIREMENTS

5.4.1 Vehicle competing in all classes must comply in all respects, with the exception of lambda control, CAN information and ~~caste~~er angles, to the technical regulations issued as being applicable to the 2025 FIA European Truck Racing Championship, including all and any Bulletins which may be issued during the course of the year, modifying, or supplementing these regulations.

5.4.3.3 Maximum ~~caste~~er 20 angle on front axle wheels degrees.

5.4.10 FRONT WHEEL SPEED SENSORS:

The fitting of any form of wheel speed sensor on the front axle, front suspension or front wheel assembly is not permitted.

5.8.1 SUSPENSION (5.8.1 MODIFICATIONS PERMITTED:)

5.8.1.4 ~~Cast~~er Angle adjusting wedges may be fitted to any axle but must be securely located by either being welded to the axle spring pad or for it to be impossible for such wedges to be removed without first removing at least two axle/spring clamping bolts. To enable the adjustment of ~~caste~~er it is allowed to modify the front axle (respecting safety) but without cutting, without welding, without removing or adding material. Class 2 trucks must also comply with regulation.5.4.3.2.

5.8.2 SUSPENSION (5.8.2 MODIFICATIONS:)

5.8.2.2 Caster Angle. For Class 1 the maximum front axle caster angle allowed is 30 degrees and Class 2 the maximum front axle caster angle allowed is ~~20~~ degrees.

5.9 TRANSMISSION (5.9.1 MODIFICATIONS PROHIBITED:)

5.9.2.1 The fitment of automatic gearboxes of any type is not allowed.

5.9.2.2 The distance from the rear of the engine to the front of the gearbox must not be altered from that specified with the original gearbox.



5.9.2.3 Fluid couplings between engine and gearbox are not allowed regardless of the manufacturer's specification.

5.9.2.4 Any form of Electronic traction control is prohibited.

5.12.4 DIMENSIONS:

Wheel diameter is unrestricted; wheel rims must be of a size to allow the fitment of Giti 315-70-22.5 tyres correctly; wheel rim width is limited to a maximum of 230mm.

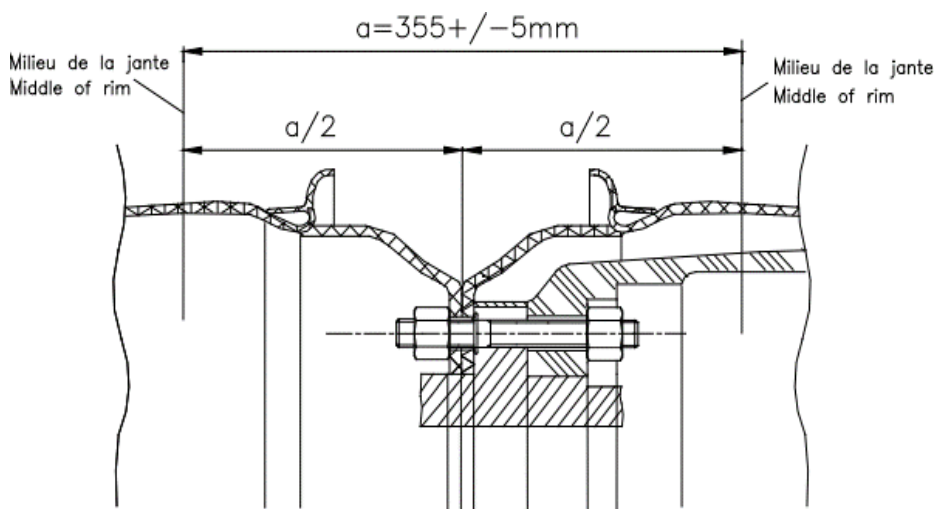

Reason:

The majority of changes correct typos. The remainder add in technical changes that were agreed in February but were lost in the edit of the published version.

Issued by: Gordon Snell

Position: Championship Coordinator/Manager

Date: 8th April 2025