

**2026 MINI CHALLENGE Trophy Sporting  
& Technical Regulations**

# **MINI CHALLENGE**

## **Trophy**

**Published Copy**

Signed Championship:



Date: 16<sup>th</sup> March 2026

## **2026 MINI CHALLENGE Trophy Sporting & Technical Regulations**

### **SR.1 Championship Regulations**

- SR.1.1 Title and Jurisdictions
- SR.1.2 Officials
- SR.1.3 Competitor Eligibility
- SR.1.4 Registration
- SR.1.5 Championship Events
- SR.1.6 Points Scoring
- SR.1.7 Awards

### **SR.2 Judicial Procedures**

- SR.2.1 Sporting Disputes
- SR.2.2 Technical Disputes
- SR 2.3 Onboard Cameras
- SR 2.4 MYLAPS X2 RACELINK SYSTEM
- SR 2.5 Technical and Sporting Queries

### **SR.3 Events and Procedures**

- SR.3.1 Entries
- SR.3.2 Briefings
- SR.3.3 Practice
- SR.3.4 Qualification
- SR.3.5 Event Procedures
- SR.3.6 Starts
- SR.3.7 Race Stops
- SR.3.8 Re-Scrutineering
- SR.3.9 Pits & Pit Lane Safety
- SR.3.10 Race Finishes
- SR.3.11 Results
- SR.3.12 Lap Timing
- SR.3.13 Operation of Safety Car
- SR.3.14 Clerk of the Course to Driver Communications
- SR.3.15 Cars Receiving Outside Assistance
- SR 3.16 Race with Respect

### **SR.4 Penalties**

- SR.4.1 Infringements
- SR.4.2 Driving Standards and Penalties

### **SR.5 Cooper Class Technical Regulations**

- SR.5.1 Introduction
- SR.5.2 General Description
- SR.5.3 Safety Requirements
- SR.5.4 General Technical Requirements and Exceptions
- SR.5.5 Chassis
- SR.5.6 Bodywork
- SR.5.7 Engine
- SR.5.8 Suspension
- SR.5.9 Transmission
- SR.5.10 Electrics
- SR.5.11 Brakes
- SR.5.12 Wheels
- SR.5.13 Tyres
- SR.5.14 Weights
- SR.5.15 Fuel Tank/Fuel
- SR.5.16 Silencing

## **2026 MINI CHALLENGE Trophy Sporting & Technical Regulations**

SR.5.17 Numbers and Championship Identification  
SR.5.18 Data Logging

### **SR.6 Commercial**

SR.6.1 Commercial Undertakings  
SR.6.2 Commercial Regulations  
SR.6.3 Penalties  
SR.6.4 Television  
SR.6.5 Advertising  
SR.6.6 Publicity  
SR.6.7 Merchandising  
SR.6.8 Event Arrangements  
SR.6.9 Paddock Regulations  
SR.6.10 Timetable Regulations  
SR.6.11 Radios  
SR.6.12 Miscellaneous  
SR.6.13 Championship Livery  
SR.6.14 Team Filming  
SR.6.15 On Board Footage  
SR.6.16 ITV Footage Requests  
SR.6.17 Press Releases  
SR.6.18 Availability of Cars

### **SR.7 Officials**

SR.7 Championship Officials

**Appendix A – Technical Query Form**

**Appendix B – Power Test Authorisation**

**Appendix C – Approved Data Loggers**

**Appendix D – Race With Respect**

**Appendix E – Trophy Log Book**

## 2026 MINI CHALLENGE Trophy Sporting & Technical Regulations

### MINI CHALLENGE Trophy Sporting Regulations

#### 1. CHAMPIONSHIP REGULATIONS

##### 1.1 Title and Jurisdiction

- 1.1.1 The 2026 MINI CHALLENGE Championship] is organised and administered by the BARC Club, and promoted by TOTAL Track Ltd, in accordance with the Motorsport UK National Competition Rules (NCR) incorporating the provisions of the FIA International Sporting Code and these Championship Regulations.

Championship Permit No. CH2026/R045 (C)  
Championship Grade: C  
Race Status: Interclub

This document defines the specific Championship regulations and structure of the Championship for both fair and safe competition and are to be adhered to by all Entrants and Drivers at all times.

The Organisers reserve the right to amend or clarify these Championship Regulations at any time during the season by way of publication of Official Championship Bulletins issued in accordance with NCR Ch. 3 App. 10 Art 4.2 and subject to Motorsport UK approval.

- 1.1.2 The MINI CHALLENGE Trophy is a motor sport Championship comprising of races only for specially built and designated 'Cooper Class' and approved invited cars.

All cars competing in the MINI CHALLENGE Trophy may be subject to inspection and sealing by Championship officials.

Invitation cars may also be accepted even if they do not meet the technical regulations.

The Organisers reserve the right to equalise performance of any invitation car, for example by the addition of ballast or modifying electronic control parameters. These cars may not score Championship points and must comply with the registration requirements set out in 1.4 of these regulations. This will be communicated to the relevant entrant competitor and registered entrants via the means of a Championship Newsletter.

- 1.1.3 The Organisers reserve the right to issue additional Official Bulletins clarifying items in the Regulations from time to time and all such Bulletins will be issued in accordance with NCR Ch.3 App.10 Art.4.2.
- 1.1.4 The Organisers reserve the right to carry out necessary or required changes to these regulations which are due to "force majeure", or for safety reasons, or reliability reasons or if requested by the authorities, by means of Official Bulletins NCR Ch.3 App.10 Art.4.2.
- 1.1.5 The Championship Officials, as listed in these Regulations, are happy to advise competitors on rules and regulations. Only the event Eligibility Scrutineer, or their deputies are empowered to give any kind of judgment regarding the eligibility of vehicles.
- 1.1.6 The Organisers reserve the right to combine the grid with other Championships or series at any time.

**2026 MINI CHALLENGE Trophy Sporting  
& Technical Regulations**

**1.2. OFFICIALS**

- 1.2.1 Championship Director: Andy Menzies or an appointed deputy  
(andy@minichallenge.co.uk)  
Championship Coordinator: Rhea Beauchamp or an appointed deputy  
(rhea@minichallenge.co.uk)  
Championship Parts Manager: Oakley Whitmore or an appointed deputy
- 1.2.2 Eligibility Scrutineer: Steven Fitzgerald
- 1.2.3 Championship Stewards: Pat Blakeney  
Alan Gow  
Ian Watson  
Adrienne Watson

Any three of the Stewards may make a decision. Replacement Stewards may be co-opted to cover “force majeure” situations.

**NCR 4.1.1.2** - The Championship Stewards may only adjudicate on any disputes, irregularities or appeals arising from the published Championship regulations. They are also empowered to consider any request from the Championship Co-ordinator to penalise any Competitor for any breach of Championship Regulations and after holding a formal hearing those Stewards may impose a penalty in accordance with NCR Chapter 2 subject to the rights of Appeal to the National Court there provided.

- 1.2.4 Clerk of the Course: Luke Caudle or an appointed deputy

**1.3 COMPETITOR ELIGIBILITY**

- 1.3.1 Entrants must be:
- a) Members of BARC and
  - b) Nominated as the Entrant by the Driver in writing at the start of the 1<sup>st</sup> race weekend entered and
  - c) be in possession of a valid MOTORSPORT UK Entrants Licence
  - d) be Registered for the Championship.
- 1.3.2 Drivers and Entrant/Drivers must:
- (a) Be current Racing Members of BARC and
  - (b) be Registered for the Championship and
  - (c) be in possession of valid Competition ‘Race Club’ status Licence, *as a minimum* or
  - (d) \*Or be in possession of the highest grade of national Race licence or valid FIA International Licence, including confirmation of a valid medical certification together with their ASN’s written consent NCR 6.3.1.6 and FIA ISC Article 2.3.7.b applies)
  - (e) If participation in the Championship requires absence from education a driver, in full time school education is required to have the approval of their head teacher and a letter stating such approval from their school in order to fulfil registration for the Championship. A driver shall not take time out of their education to participate in motor sport without the prior written approval of their education establishment.
- 1.3.3 Acceptance of registration is entirely at the discretion of the Championship Organisers and may be withdrawn at any time.
- 1.3.4 A Team is a commercial race company or racing team hosting drivers in providing race services or covered accommodation in the Championship and as a result receives

## 2026 MINI CHALLENGE Trophy Sporting & Technical Regulations

financial gain where, the principal is not also the parent/guardian. Being considered as being a team includes the use of team names, team sticker kits and team race suits/clothing.

Any fees related to team costs, including running expenses or race car hire, are contractually the responsibility between the driver and race team and not the Championship.

A Team shall at all times uphold and respect the provisions of the Code, the Championship Regulations and these Championship Regulations as may be amended from time to time and shall;

- (a) hold a valid Motorsport UK Entrant licence;
- (b) have at least £5 million Public Liability Insurance;
- (c) uphold the values of the Respect Code and all applicable Motorsport UK policies and guidance;
- (d) act in a professional manner at all times and not act or permit any member of the Team to act in such a manner as to bring motor sport, the Championship or Motorsport UK or any its officers and officials into disrespect;
- (e) adhere to the Motorsport UK Safeguarding Policy and guidance documents, complete Safeguarding training when required and ensure that any person undertaking Regulated Activity is the holder of a valid suitability check certificate supplied through Motorsport UK;
- (f) ensure that representative (s) and driver coaches attend training/briefing when required;
- (g) adhere to the Championship Regulations in respect of anti-alcohol and illicit drugs as well as Motorsport UK processes for anti-alcohol and illicit drugs testing;
- (h) nominate one member of their Team as the Team Representative at each event including but not exclusively for the purpose of all judicial proceedings at Events and who shall be present at all judicial proceedings concerning drivers entered under that Team licence in substitution for the driver Parent/Legal Guardian.

1.3.5 It is recommended the Team has:

- (a) a designated team member as a 1<sup>st</sup> 4Sport, Level 2 qualified coach;
- (b) a designated UKAD Certified Advisor, and
- (c) be responsible for carrying out and documenting a risk assessment of their activities; (risk assessment management tool available from Motorsport UK)

1.3.6 All competitors must sign-on at Events that they compete in and all necessary documentation must be available to be presented for checking at all rounds times upon the demand of the Officials.

### 1.4. REGISTRATION-

1.4.1 All Drivers and Entrants must complete the official MINI CHALLENGE Trophy Registration Form and return it to the Championship Coordinator in order to enter the Championship. It should be clearly understood that by signing the form all competitors acknowledge their agreement to be bound by the rules and regulations contained in the Championship Regulations, Championship Terms and Conditions and those stipulated by the Organising Club, the Championship Office, the Event Organisers and the MOTORSPORT UK.

## **2026 MINI CHALLENGE Trophy Sporting & Technical Regulations**

1.4.2 Where a car is entered for the MINI CHALLENGE Trophy by someone other than the Driver, it will be necessary for that Entrant (who must be in possession of a valid MOTORSPORT UK Entrant's Licence) to complete the Registration Form and nominate the Driver. The nominated driver must also complete the driver section of the registration form.

1.4.3 Only one Driver may be nominated on each Registration Form.

To cater for "force majeure" situations, additional drivers for a registered car may, subject to approval by the Championship Organisers, be registered for a fee of £200+VAT over and above the standard entry/registration fee.

1.4.4 The maximum number of Championship entries for the Cooper Class will be 34 but may be increased to 42 at any time.

a) Only drivers entered for at least 50% of race events prior to the start of the first permitted race event will be eligible for Championship points in respect of the drivers Championship, cups and Team award.

b) Reserve entrants may be accepted when the total number of entries exceeds 34.

c) Reserve positions will be in order of receipt of the entry at the start of the season.

d) Reserves will only race at rounds where the maximum grid number exceeds 34 or where a confirmed entry withdraws or where section 1.5.7 has been applied.

e) Guest & Invitation entries may be accepted subject to the circuit limit.

f) Where a guest driver finishes in the top three, they will be allowed to collect any prize or trophy but will not score Championship points.

g) Where a guest driver finishes in a Championship point scoring position, all drivers finishing behind the guest driver will be moved up one position for the purposes of Championship points only. This will apply for Championship points applicable in races and in respect of the fastest lap in qualifying and in respect of fastest lap in races. For the avoidance of doubt this means that the fastest lap in qualifying or a race achieved by a Championship entrant, (i.e. not a guest driver) will be awarded the points for fastest lap in qualifying or a race.

h) Invitation car entries may be accepted to race in the MINI CHALLENGE Trophy. Where an invitation car is entered, the Championship Organisers may add ballast or any other measure with the aim of ensuring that an invitation car is no faster than the other cars racing. Invitation car entries will not score points or be eligible for trophies.

i) Acceptance of reserve, guest and invitation entries is at the Organisers discretion.

j) The Organisers reserve the right to split or amalgamate classes or combine with other Championships. This will be communicated via the means of a bulletin.

1.4.5 For the Trophy Class applications for registrations open on the first business day of the calendar year.

Early-bird pre-registrations may be made before this date.

## 2026 MINI CHALLENGE Trophy Sporting & Technical Regulations

Race numbers will be allocated on a strict ‘first come first served’ basis with the exception of Number 1 which will be reserved for the previous seasons Cooper Class Champion.

A three-digit race number can only be used with the approval of the Chief Timekeeper prior to the start of the season. This is limited to five 3-digit numbers per race weekend across the whole grid.

- 1.4.6 No Club organising an event for the Championship, will accept event entries unless the Competitor has previously registered with the Championship Office.
- 1.4.7 Acceptance or rejection of registrations is entirely at the discretion of the Championship Officials.
- 1.4.8 Competitors registered for the season will be issued with:
  - (a) At Non TOCA events - 4 or 5 team passes each weekend and one support vehicle pass for the season.
  - (b) At TOCA events - 5 entry tickets each weekend and 1x competitor pass for the season.

Team passes will be given to Team Managers to distribute and must be distributed to drivers and team members as team members must be ready to present their pass if in the assembly area, the pitlane or Parc fermé. Passes will be randomly inspected. The support vehicle pass must be displayed in the support vehicle when in the paddock. Only one support vehicle is allowed per car. Any breach of this regulation will be reported to the Clerk of the Course. Please note that team passes are for support teams not for family and friends, if team members do not have passes, they may be refused entry to the assembly area and/or pit lane.

Should there be no passes available, the Championship organisers reserve the right to issue tickets instead of passes.

### 1.5 CHAMPIONSHIP EVENTS

- 1.5.1 The MINI CHALLENGE Trophy will consist of race events as set out in the calendar below:

Date(s)	Event Type	Test Days	Race Days	Venue	Format	Rounds	Org Club
4-5 April	Race	1 Direct Booking	2	Silverstone NAT*	1x15 min Quali 3x15 min Race	1,2,3	MSV
23-24 May	Race	1	2	Snetterton TOCA*	2/3 Test Sessions 1x30 min Quali 3x20 min Race	4,5,6	BARC TOCA
20-21 June	Race	1 Direct Booking	2	Pembrey*	1x15 min Quali 3x15 min Race	7,8,9	BARC
25-26 July	Race	1	2	Thruxton TOCA*	2/3 Test Sessions 1x30 min Quali 3x20 min Race	10,11,12	BARC TOCA
22-23 August	Race	1	2	Donington Park (GP) TOCA*	2/3 Test Sessions 1x30 min Quali 3x20 min Race	13,14,15	BARC TOCA
26-27 September	Race	1	2	Croft TOCA*	2/3 Test Sessions 1x30 min Quali 2x20 min Race	16,17	BARC TOCA
31 Oct – 1 November	Race	1 Direct Booking	2	Brands Indy* British Truck Racing Championship	1x15 min Quali 3x15 min Race	18,19,20	BARC

\*Subject to valid track licence.

## **2026 MINI CHALLENGE Trophy Sporting & Technical Regulations**

- 1.5.2 Within each event the actual timetables will vary. Please refer to the specific Event Instructions and the BARC Competitor Information App.
- 1.5.3 The Championship Organisers and Promoters reserve the right to cancel, postpone or substitute events in the MINI CHALLENGE Trophy for reasons of “force majeure” and no responsibility will be accepted for loss or damage incurred. NCR Ch.12 App.2 Art.4.
- 1.5.4 If the Championship or any event is oversubscribed in relation to the relevant circuit limit the organisers may at their discretion run Qualification Races and may add races in order to accommodate this. This will be communicated via the means of a bulletin.
- 1.5.5 If the Championship or any event is oversubscribed in relation to the relevant circuit limit the organisers may at their discretion give priority to competitors entered for the entire Championship.
- 1.5.6 If the event is oversubscribed the organisers may at their discretion select starters for the races which will be communicated in writing via the Final Instructions or by a Bulletin. Using any of the following methods:
- (a) practice/qualification times, or
  - (b) handicap ballast, or
  - (c) finishing order in a preceding race, or
  - (d) selection made with the object of placing the fastest driver at the front, or
  - (e) current positions in a Championship
- 1.5.7 The organisers may also, at their discretion, increase the number of races and allocate drivers to some races such that each driver takes place in the number of races originally allocated to that event. e.g.

Number of Races Originally Scheduled is 3

Circuit limit - 34 cars

Qualifiers - 40 cars

Group A is qualifiers 1,5,9,13 etc

Group B is qualifiers 2,6,10,14 etc

Group C is qualifiers 3,7,11,15 etc

Group D is qualifiers 4,8,12,16 etc

Race 1 Groups A,B,C

Race 2 Groups B,C,D

Race 3 Groups A,B,D

Race 4 Groups A,C,D

Points will then be allocated for each race such that each competitor has the opportunity to score points in the number of races originally planned.

Where required, competitors may be split to more or less than 4 groups and more or less than 4 races may be run as required.

The organisers may at their absolute discretion require any combination of classes to race together in the same race.

The organisers may at their absolute discretion vary the length of races at any time.

## 2026 MINI CHALLENGE Trophy Sporting & Technical Regulations

### 1.6 POINTS SCORING

1.6.1 All races will be points scoring.

1.6.2 For each class points are scored by Drivers for each round on the following scale:

<b>Position in Class</b>	<b>Points</b>	<b>Position in Class</b>	<b>Points</b>
1st	50 pts	11th	24 pts
2nd	44 pts	12th	23 pts
3rd	40 pts	13th	22 pts
4th	37 pts	14th	21 pts
5th	34 pts	15th	20 pts
6th	32 pts	16th	19 pts
7th	30 pts	17th	18 pts
8th	28 pts	18th	17 pts
9th	26 pts	19th	16 pts
10th	25 pts	20th and below	15 pts

a) Should a race run for less than 50% of the race time (based on the length of the race as planned at the start of the race) then 50% of the normal points will be awarded. Fastest race lap points are excluded from this ruling, i.e. full points will be awarded.

b) All Drivers including those who do not finish and therefore do not score points for their finishing positions, but are eligible for the following:

Fastest time in Qualifying            6 pts

Fastest race lap                        3 pts

c) Should a race be stopped, the fastest lap can be achieved in either part 1 or part 2 of a race.

d) Should a guest driver set the fastest time in either Qualifying or a race, the bonus points will go to the fastest driver eligible for the Championship.

e) The bonus points for the fastest lap time in Qualifying will be added to the points scored in the race for which those times have set the grid - ie, the final race of the weekend.

f) A driver will score points toward the Rookie Cup only if at least three eligible drivers have entered before season registration closes, which occurs prior to the first round. All participating drivers must also meet the following eligibility requirements:

- i) The driver must not have competed in more than 6 MINI CHALLENGE race events.
- ii) The driver must not have finished in the overall top 3 in any current or previous senior TOCA support Championship.
- iii) The driver must not have entered a British Touring Car Championship full season or a British GT full season.

g) A driver will score points toward the Graduate Cup only if at least three eligible drivers have entered before season registration closes, which occurs prior to the first round. All participating drivers must also meet the following eligibility requirements:

- i) must not be registered for the rookie cup.
- ii) The driver must not have competed in more than 12 MINI CHALLENGE race events.

## 2026 MINI CHALLENGE Trophy Sporting & Technical Regulations

iii) The driver must not have finished in the overall top 3 in any current or previous senior TOCA support Championship.

iv) The driver must not have entered a British Touring Car Championship season or a British GT season.

h) A driver will score points toward the Directors Cup only if at least three eligible drivers have entered before season registration closes, which occurs prior to the first round. All participating drivers must also meet the following eligibility requirements:

i) The driver must be aged 35 and over at the time of registration.

ii) The driver must not have won the MINI CHALLENGE in their entered Class in the last 3 seasons.

iii) The driver must not have finished in the overall top 3 in any current or previous TOCA support Championship.

iii) The driver must not have entered a British Touring Car full Championship season or a British GT full season.

A driver may voluntarily withdraw themselves from the Rookie Cup and/or the Directors Cup whilst still scoring points for the overall Championship or another Cup in their Class.

If a dead heat is declared, all the Drivers concerned will score the average points for all positions which are drawn. For example, 1<sup>st</sup> and 2<sup>nd</sup> are a dead heat. The points awarded will be  $50+44=94/2=47$ .

- 1.6.3 In the event of a tie in Championship or Cup points between two or more Competitors, the number of wins achieved by the Competitors involved in the tie will be used to determine the overall final standing.

Should a tie still exist, it will be resolved:-

i) By taking into account the number of second places achieved; then third places etc. etc.

ii) By taking into account the number of competitors (i.e. event finishers) beaten during the season by each Competitor.

Disqualification from the event will mean that scores from all races at that event will be dropped.

- 1.6.4 All MINI CHALLENGE Trophy rounds will score points as per 1.6.2.

- 1.6.5 Where the race distance has been reduced, it shall still count as a full points scoring round.

- 1.6.6 In order to score points, collect trophies and awards, all cars and Drivers competing in the MINI CHALLENGE Trophy may be required to display and wear the MINI CHALLENGE Trophy Sponsors' decals and badges in the nominated position on clothing and vehicles or may be required to wear a Championship race suit. Where a Championship race suit is required dispensation to wear another race suit may be provided by the Championship Organisers.

Note the requirements of SR.4 concerning penalties.

- 1.6.7 Any Competitor who has not presented a valid, complete and current Cooper Logbook shall not be eligible to score Championship points or collect trophies.

## **2026 MINI CHALLENGE Trophy Sporting & Technical Regulations**

### **1.7 AWARDS**

1.7.1 All Championship awards are to be provided by the MINI CHALLENGE Trophy, their associated sponsors and Total Track Ltd.

1.7.2 All trophies will be presented to the Driver(s). Drivers are required to attend presentations.

1.7.3 Trophies or medals will be presented at each race to drivers as follows:

1st, 2nd and 3rd Overall

Where applicable - 1<sup>st</sup> Rookie Cup

Where applicable - 1<sup>st</sup> Graduate Cup

Where applicable - 1<sup>st</sup> Directors Cup

Additional awards may be given at the sole discretion of the Championship Organisers.

1.7.4 End of season awards are Trophies and will be presented as follows (see also SR1.6.3):

NCR Ch.4 App.0 Art.1.16 applies.

The MINI CHALLENGE Cooper Annual Trophy to the MINI CHALLENGE driver, who accrues the highest number of points in the Cooper Class.

1st, 2nd and 3rd Overall

Where applicable - 1<sup>st</sup> Rookie Cup

Where applicable - 1<sup>st</sup> Graduate Cup

Where applicable - 1<sup>st</sup> Directors Cup

Where applicable - Team award

1.7.5 Other Awards may be announced in Championship Bulletins.

1.7.6 In the event of any Provisional Results or Championship Points Tables being revised after any provisional awards presentations and such revisions affecting the distribution of any awards, the Competitors concerned must return such awards to the MINI CHALLENGE Trophy office in good condition within 7 days.

1.7.7 Any annual awards must be returned to the Organisers before the last round of the following season's events.

## **2. JUDICIAL PROCEDURES**

### **2.1 SPORTING DISPUTES**

2.1.1 Disputes on the Sporting Regulations and their application by the Championship which arise during the season will be settled by the Championship Stewards in accordance with NCR Ch.2 App.5, these Regulations and any Official Bulletins that have been issued.

## 2026 MINI CHALLENGE Trophy Sporting & Technical Regulations

The case for any dispute must be submitted in accordance with National Competition Rules together with the appropriate MOTORSPORT UK protest or appeal fee.

The Championship Stewards' judgment will be subject only to the Right of Appeal to MOTORSPORT UK.

- 2.1.2 In order to maintain standards of conduct, the Championship Organisers will monitor all Officials/Observers reports of adverse behaviour at race event. If any individual is included on two such reports during one racing season the Championship Organisers will request the Clerk of Course at future race events to consider specific observation of that driver's or team member's conduct. The Championship Coordinator may refer any Competitor to the Championship Stewards pursuant to Motorsport UK (NCR Ch.4 App.1 Art.1.2).

### 2.2 TECHNICAL DISPUTES

- 2.2.1 The Eligibility Scrutineer/Event Chief Scrutineer, in consultation where necessary with the Championship Technical Officers, reserve/s the right to check and ask to be removed and replaced by the Team or Competitor, any suspect part directly with a standard part as supplied by Total Track Ltd, MINI or any of its nominated dealers or suppliers.

The Eligibility Scrutineer / Event Chief Scrutineer, in consultation where necessary with the Championship Technical Officers, also reserve/s the right to impound individual parts or the whole car without prior notification.

Parts or cars removed for checking elsewhere will be marked by official MOTORSPORT UK approved seals and a certificate of sealing will be handed to the competitor or their agent. (See current NCR Ch.7 App.12).

- 2.2.2 Note the requirements of SR.4

### 2.3 ONBOARD CAMERAS

In accordance with NCR Ch.7 App.9 and the following regulations.

- 2.3.1 All competitors in the MINI CHALLENGE Trophy Championship are required to carry front and rear facing on board in-car camera for the primary purpose of safety. Footage from the cameras may be used where there is an incident which is subsequently brought before the Clerk of the Course for investigation. The decision to review any such video footage is at the discretion of the Clerk of the Course and, or, the Stewards of the event.
- 2.3.2 It is the competitor's sole responsibility to ensure safe installation and effective operation of the camera equipment.
- a) Each camera must be from the approved list, approval for any camera not on the approved list must be submitted to the Championship organisers no later than the Monday of the week leading up to the event.

Approved list:

- AiM SmartyCam HD 2.1 or 2.2 (any model with 84 or 120 degree lens)
- AiM SmartyCam 3 (any model with 84 or 120 degree lens.)
- GoPro (any model)
- VBox Video HD2
- VBox HD Lite

## **2026 MINI CHALLENGE Trophy Sporting & Technical Regulations**

The front facing camera must be mounted from the roll cage on the passenger side of the vehicle. The position of the camera must capture an image that provides a 'drivers' eye view' that must include the steering wheel, dashboard, gearstick and a view of the circuit ahead with a field of vision of at least 100 degrees. The position and image will be approved by the Championship at the first round the competitor competes in. The Championship will retain a screenshot from the approved recording to act as a reference image and a copy will also be provided electronically to the competitor. The competitor must ensure the camera maintains its originally approved capture field. If the capture field deviates from the reference image the competitor may be reported to the Clerk of the Course for breach of these regulations.

The rear facing camera must be mounted from the roll cage behind the driver and be angled to provide a clear view out of the rear window providing a field of vision of approximately 100 degrees to include the entire rear window and the rear quarter windows.

Competitors must declare the make and model of the front and rear facing camera on the Log Book.

All cameras must be mounted and/or programmed such that the images appear with correct orientation (i.e. the top of the view is at the top of the monitor).

No other cameras may be fitted unless written permission is received from the Championship Organisers.

b) The Championship may at any time decide to issue Championship front and/or rear cameras. When this happens regulation 2.3.2 b) will replace regulation 2.3.2 a) in its entirety.

Championship cameras must be fitted in accordance with Championship issued fitting instructions. It is the Competitor's sole responsibility to ensure safe installation and effective operation of the camera equipment. If a competitor suspects an issue with a camera they must make the Championship Organisers aware no later than one hour before the scheduled start time of any session.

If the Championship decides to only issue a front facing camera then competitors must provide their own rear facing camera. The rear facing camera must be mounted from the roll cage behind the driver and be angled to provide a clear view out of the rear window providing a field of vision of approximately 100 degrees to include the entire rear window and the rear quarter windows.

Competitors may fit a secondary front facing camera for the primary purpose of driver development.

Secondary cameras must be declared on the Log Book and where a secondary camera is declared it must be fitted and correctly working at all times. The secondary camera may not block or interfere with the Championship camera in any way.

No other cameras may be fitted unless written permission is received from the Championship Coordinator.

2.3.3 At all times cameras must be fitted in accordance with National Competition Rules and be approved by the Chief Scrutineer in accordance with NCR Ch.7 App.9 (1.4). The mounting of any camera must be specifically approved by the Chief Scrutineer.

## 2026 MINI CHALLENGE Trophy Sporting & Technical Regulations

Any mountings must use a mechanical means of attachment sufficiently robust to withstand anticipated stresses and vibration and must not present any sharp edges or projections in the vicinity of the driver's body or helmet. Where possible, a secondary means of attachment should be used. Suction mounts are not acceptable as the primary mounting method. Where cameras are fitted by professional TV or film companies, the Chief Scrutineer has discretion to approve non-mechanical mountings.

- 2.3.4 Fitting of cameras to helmets is only permitted in accordance with Ch.7 App.9 (1.8). and may only be done with written permission from the Championship Organisers.
- 2.3.5 Unless a camera is issued by the Championship, Competitors must supply their own cameras and provide their own memory cards and have a spare memory card for each camera available at all times. All memory cards must be labelled with the Competitor car number and either an 'F' to denote a front camera or an 'R' to denote a rear camera. All memory cards must be cleared for each session. Playback of all video footage must be possible at the event by regular means such as a laptop computer.

The Championship will provide memory cards for Championship issued cameras only, to be used for each qualifying and race session. It remains the competitors responsibility to ensure that the cameras and SD cards are working at all times. If a competitor suspects an issue with a memory card they must make the Championship Organisers aware no later than one hour prior to the scheduled start time of any session. Memory cards remain the property of the Championship and footage must not be deleted from memory cards.

- 2.3.6 All memory cards will be retained by the Championship after all qualifying and race sessions. Entrants may collect SD cards after they have been notified by the Championship Organisers that memory cards are released from Parc Ferme. Where the Championship has issued memory cards, Entrants may collect footage from the Championship Officials after receiving notification that footage is available. Entrants are responsible for providing suitable USB or SD card storage media.

Video footage from any in-car camera may not be reviewed by the Competitor until they have been notified by the Championship Organisers that memory cards have been released from Parc Ferme.

- 2.3.7 In the event of judicial action being instigated, all relevant on-board footage must be retained until the time period for conclusion of all judicial matters has elapsed.
- 2.3.8 Where it is necessary for a Clerk of the Course to review footage after an Event, such footage should normally be reviewed within a period of 7 days of the Event.
- 2.3.9 In the event that no video footage is available upon request (other than due to a proven defect with the equipment) sanctions may be applied. The burden of proof to establish the cause of such failure will lie with the competitor.
- 2.3.10 All rights including copyright in relation to footage captured by on board cameras, no matter that the camera is owned by the Competitor or the Organiser/Promoter will belong to the Organiser and/or Venue Owner/Operation and may not be shared or otherwise used for broadcast or commercial purposes or on social networking sites, forums or any other internet media without permission of the Organiser and/or Venue owner/operator (if applicable).
- 2.3.11 Competitors are reminded that in-car footage must not be used in such a way as to risk bringing the MINI CHALLENGE Trophy or the sport into disrepute and must also only use footage in such a way as to not breach the Championship commercial regulations.

## **2026 MINI CHALLENGE Trophy Sporting & Technical Regulations**

- 2.3.12 Competitors must make available on request in car camera footage for broadcast or use on MINI CHALLENGE Trophy social media, including, but not limited to posting the pole lap on social media platforms.
- 2.3.13 At any time before or during the season and at the sole discretion of the organisers, some or all Competitors may be required to use cameras supplied by the Championship. Should this be the case, a rental charge of up to £150 plus VAT may be applied. The cameras and any accessories remain the property of the Championship and must be returned to the Championship within 2 hours of release from Parc Ferme at the final round of the Championship. For any competitor not competing at the final event, the cameras must be returned to Total Track Ltd within 14 calendar days of the final round of the Championship. Failure to return cameras and any accessories within this time will result in the competitor being liable to, and promptly on demand pay, the Championship for all costs associated with replacing the equipment. The competitor is liable to pay the Championship for any costs incurred in relation to any repair required as a result of any damage to the cameras or accessories whilst in the competitors possession, including if the camera or accessory cannot be repaired, the cost of replacement.
- 2.3.14 Any breach of camera regulations may be subject to the penalties provided for in NCR Ch.2 App.2 Art.1 and on a case-by-case basis; they may include but are not limited to:
- A Reprimand
  - Fine of up to £1,045.
  - Time Penalty.
  - Grid Place Penalty.
  - Disqualification from the Race.
  - Disqualification from the event.

### **2.4 MYLAPS X2 RACELINK SYSTEM**

- 2.4.1 It is mandatory to fit a MYLAPS X2 RACELINK SYSTEM Loom and Aerial at all TOCA race events. In the event that the MYLAPS X2 RACELINK SYSTEM System Loom and/or Aerial is not fitted and working the Championship Coordinator may report this to the Clerk of the Course.
- 2.4.2 It is mandatory to hire and fit the MYLAPS X2 RACELINK SYSTEM System display at all TOCA race events. In the event that the MYLAPS X2 RACELINK SYSTEM display is not fitted and working the Championship Coordinator may report this to the Clerk of the Course.
- 2.4.3 It is mandatory to return the MYLAPS X2 RACELINK SYSTEM System. In the event that the MYLAPS X2 RACELINK SYSTEM is not returned at the end of each race event the Championship Coordinator may report this to the Clerk of the Course.
- 2.4.4 Any breach of MYLAPS X2 RACELINK SYSTEM regulations may be subject to the penalties provided for in NCR Ch.2 App.2 Art.1 and on a case-by-case basis; they may include but are not limited to:
- A Reprimand
  - Fine of up to £1,045.
  - Time Penalty.
  - Grid Place Penalty.
  - Disqualification from the Race.
  - Disqualification from the event.

## 2026 MINI CHALLENGE Trophy Sporting & Technical Regulations

### 2.5 TECHNICAL & SPORTING QUERIES

Any technical or sporting query must be made to the MINI CHALLENGE Trophy Office in writing. If the matter is technical in nature and relating to your own car the form in

Appendix A of these regulations must be used. All Technical Query Forms must be submitted 30 minutes prior to any session unless under special circumstances and/or agreed with the Eligibility Scrutineer. All queries will be answered in writing and may be published to all entrants/competitors.

### 3. EVENTS & PROCEDURES

#### 3.1 ENTRIES

3.1.1 Registration forms are available at [www.minichallenge.co.uk](http://www.minichallenge.co.uk)

Supplementary regulations may also be distributed electronically.

3.1.2 Registered Competitors are responsible for sending in correct and complete entries to the CHALLENGE Office, who will then forward them to the Organising Clubs.

3.1.3 All entry fees for events in the MINI CHALLENGE Trophy will be paid to the MINI CHALLENGE Trophy promoter, Total Track Ltd or where advised, to the organising club.

3.1.4 All correct and complete entries are to be acknowledged by the Organising Club of individual events directly to the MINI CHALLENGE Trophy office.

3.1.5 Incorrect or incomplete entries will be held in abeyance until they are complete and correct.

3.1.6 Any withdrawal of Entry made after acceptance of any entry, must be notified in writing to the Championship Coordinator and the organising club not less than 3 days prior to the event in question. NCR Ch.3 App.11 Art.1.1 applies.

3.1.7 There will be no refund of entry fees and any entry fees unpaid will still be due irrespective of the reason for withdrawal or disqualification.

3.1.8 Testing - A test day will usually be available, the day preceding the event, for competitors to familiarise themselves with the circuit. This may be held under test day or track day rules and organised independently of the MINI CHALLENGE Trophy. Other than for TOCA rounds it is the competitors' responsibility to check circuit availability and book testing. There may be occasions where the test day is not on the day preceding the event. Other than for TOCA rounds the test day is not part of the race weekend and not the responsibility of Total Track Ltd, the MINI CHALLENGE Trophy. Test days are not included in the permit issued by Motorsport UK.

There may also be a number of other official test days, including a media day which will also be subject to these regulations, but the entry may be at an additional cost. Attendance at official test days is not mandatory with the exception of a media day where attendance may be mandatory.

Entirely at the discretion of the organisers and at any time, the provision of test day/s may be removed and a refund of entry fee at least equal to the previous year typical a general test day entry fee may be made to allow competitors to book a test day directly with the circuit.

## **2026 MINI CHALLENGE Trophy Sporting & Technical Regulations**

Should a competitor cumulatively cause more than 1 red signal/session stoppage during pre-race test days they shall be required to miss the first 10 minutes of the next qualifying session. The competitor may request this to the Clerk of the Course to evaluate the evidence, who may on request review any evidence provided by the competitor that demonstrates that the red signal/session stoppage was caused by reasons other than driver error. If the Clerk of the Course agrees that the red signal/session stoppage was due to reasons other than driver error, the Clerk may remove this red signal/session stoppage from the competitors cumulative tally and if applicable remove the penalty. For the avoidance of doubt, 2 red signals/session stoppages cumulatively will result in a 10 minute penalty at the next qualifying session, 3 red signals/session stoppages will result in a 10 minute penalty at the next two qualifying sessions, 4 red signals/session stoppages will result in a 10 minute penalty at the next three qualifying sessions etc. Once a competitor has served all the penalties they have been issued their red signal/session stoppages tally will reset to zero.

At any time from 5 working days prior to the start of the season until the end of the season should a competitor drive a MINI CHALLENGE Cooper Class car on track they must notify the Championship Coordinator at least 48 hours prior to the on track activity. Should the competitor fail to notify the Championship Coordinator the Championship Coordinator may refer the competitor to the Clerk of the Course for the possible imposition of penalties.

At any time, the organisers may also refer a competitor to the Clerk of the Course due to driving standards concerns during test sessions and the Clerk of the Course may apply any of the following penalties:

A reprimand or fine of up to £1045  
Disqualification from the next session  
Disqualification from the event

- 3.1.9 The closing date for entries shall not be less than 3 days before the event. NCR Ch.3 App.5 Art.10.1.

### **3.2 BRIEFINGS**

The Organising Clubs will notify Competitors of the times and location for all briefings in the Final Instructions either electronically, or at the event. Competitors must attend all briefings or be subject to a penalty.

Any driver operating a mobile device, tablet or similar device will be deemed to be absent and may be fined or subject to a penalty.

Any written briefing is an Official Document.

### **3.3 PRE-RACE-EVENT TEST DAY**

- 3.3.1 There will usually be a pre-race event test day on the Thursday or Friday immediately before a race event. For TOCA rounds competitors will automatically be entered for the pre-race event test day. For Non-TOCA events competitors must book directly with the relevant circuit.
- 3.3.2 At TOCA events there will usually be 2 or 3 sessions but may be other formats as required. For Non-TOCA events the testing format will be set by the test/track day organisers.
- 3.3.3 All Competitors will be allocated nominated pit lane positions based on garage numbers. This will be communicated before the race event.

## **2026 MINI CHALLENGE Trophy Sporting & Technical Regulations**

### **3.4 QUALIFICATION PRACTICE**

- 3.4.1 Should any Qualifying Practice session be red signal/session stopped the Clerk of the Course shall not be obliged to resume or re-run the session; the decision of the Clerk of the Course shall be final.
- 3.4.2 Any driver deemed to have caused a red signal/session stoppage during any Qualifying will have their Fastest Lap time cancelled. If, in the opinion of the MINI CHALLENGE Clerk of the Course, a red signal/session stoppage during any Qualifying is caused deliberately or by driving in a manner not compatible with general safety by any driver and/or entrant then the driver(s) concerned may have all their times from that session cancelled.
- 3.4.3 At every event each driver will be given the opportunity to qualify as per NCR Ch.12 App.6 Art.3.2.
- 3.4.4 At the first race event each year the order in which cars/drivers will be positioned in the assembly area will be determined by random draw. One car number from each class will be drawn from a hat/bag in the drivers briefing (or other random system). This driver will be positioned as the first to leave assembly in qualifying. All other drivers will be lined up in numerical order behind the first car to be drawn. For subsequent race event cars/drivers will be lined up based on their position in the Championship with the Championship leader positioned first and be first to leave the assembly area at the start of the session. Failure to comply with this regulation may be result in penalties on a case by case basis; they may include but are not limited to:

A reprimand or fine of up to £1,045  
Time Penalty  
Grid Place Penalty  
Disqualification from the Session  
Disqualification from the event

- 3.4.5 Competitors who post qualifying times more than 107% of the pole time shall not be able to race at the event unless they were within 107% at the previous event, or, at the Clerk of the Course's discretion they agree to additional testing before the next event.

### **3.4.6 Grid Positions**

Each competitor will compete in one qualifying session, from which;

#### **Race One**

Race one grid positions will be determined by the competitors' second best qualifying time, as published in the results and subject to any judicial matters.

#### **Race Two** (Only applies where the event consists of 3 races)

In the event of a race weekend featuring three races, the grid for the second race will be determined by reversing the top 6-12 finishers inclusive from the previous race as published in the results and subject to any judicial matters, with the number to be picked at random by the winner of the previous race, or someone nominated by the Organisers as soon as practical after the finish of that race.

If less than 6 cars start the second race, then all cars grid positions will be reversed.

## **2026 MINI CHALLENGE Trophy Sporting & Technical Regulations**

All other classified finishers will be allocated grid positions in accordance with their finishing order from the previous race. Competitors not classified as finishers in the previous race will start in reverse retirement order. Note 4.2.2 penalties.

Where a grid penalty is to be applied the penalty will be applied after the grid has been reversed.

Where a time penalty is applied, if, after the grid is reversed this results in a competitor being placed in a higher grid position than before the grid was reversed they will be demoted to the grid position that would have applied prior to the application of the time penalty.

For the avoidance of doubt, where a competitor receives any penalty, they shall never benefit from a higher grid position as a result of the reverse grid draw than they would have had prior to the penalty.

### **Final Race**

The final race grid positions will be determined by the competitors' best qualifying time, as published by the in the results and subject to any judicial matters.

For clarification, at events with two scheduled races the final race will be the second race, at events with three scheduled races the final race will be the third race.

- 3.4.7 Where Classes/Championships race together, the class of cars/Championship with the fastest qualifying time will be at the front of the grid with a gap to the next fastest Class/Championship and a further gap to the next fastest class/championship etc etc.

The term fastest qualifying time relates to the fastest individual time in the Class/Championship rather than the average of the class. This is irrespective of whether some cars individually post times faster than some cars in other Classes/Championships in qualifying & regardless of results of preceding races.

The gap between Classes/Championship will be the largest possible considering the restriction of the circuit and the gap will be entirely at the discretion of the Clerk of the Course.

### **3.5 EVENT PROCEDURES**

- 3.5.1 The event procedure for the Races will be distributed to competitors by way of Official Bulletins; these must be read in conjunction with individual Event Supplementary Regulations which take precedence.

The Organisers may include restrictions on the time when awnings can be dismantled. This will be at the Organisers sole discretion and competitors will be notified prior to the event. If a restriction is communicated, it will form part of these regulations.

- 3.5.2 Once a car is positioned in the Assembly area power must be isolated by the competitor until instructed by the Championship Coordinator to start engines. Any competitor found not to have isolated their car will be referred by the Championship Eligibility Scrutineer to the Clerk of Course for the application of penalties including but not limited to disqualification from the session.

## 2026 MINI CHALLENGE Trophy Sporting & Technical Regulations

### Adverse Weather Procedures

- 3.5.1 At the discretion of the Clerk of the Course and in the event of a sudden change of weather the release of cars from Assembly Area may be delayed to facilitate the changing of tyres if not doing so might put the safety of drivers, teams or circuit staff at risk.
- 3.5.2 The car's rain light must be illuminated at all times when wet-weather tyres are fitted or when otherwise instructed by the Clerk of Course.

### 3.6 STARTS

Unless modified by the Organising Club's Standing Regulations, the following regulations shall apply:-

All cars will be released to form up on the grid prior to the start in formation as specified on the grid sheet.

- 3.6.1 The start will be via Standing or Rolling Start. Both Standing and Rolling Starts may be used, Competitors will be informed of the start procedures at the drivers briefing or before via a bulletin.

The minimum Countdown procedures/audible warnings sequence will be:-

- a) 1 minute to the start of the Green Signal/Pace Lap - Start engines/Clear Grid.
- b) 30 seconds - Visible and audible warning for start of Green Signal/Pace Lap.
- c) After completion of the Green Signal/Pace Lap vehicles will resume their grid positions for a standing start.
- d) A five second board will be used to indicate that the grid is complete.
- e) The red lights will be switched on five seconds after the board is withdrawn and switched off to indicate the start of the race.
- f) After completion of the Pace Lap the red lights will be on and the vehicles must approach the start line Grid order with the pole setting the pace. The red lights will be switched off to indicate the start of the race.

- 3.6.2 Any car removed from the grid after the 1-minute stage or driven into the pits on the Green Signal/Pace Lap shall be held in the pit lane and may start the race after the last car to take the start from the grid has passed the start line or pit exit lane whichever is the later. Any car unable to take up starters order may join the race from the pitlane up until the leader has completed the first racing lap. For the avoidance of doubt cars will not be permitted to join the race once the leader has started the second racing lap. Where a race is declared a no contest, all available competitors will restart from their original grid positions.
- 3.6.3 Any drivers unable to start the Green Signal/Pace lap or start are required to indicate their situation as per current NCR Ch.12 App.6 Art.6.11 and any drivers unable to maintain grid positions on the Green Signal/Pace lap to the extent that ALL other cars are ahead of them, may complete the Green Signal/Pace lap but MUST remain at the rear of the last row of the grid but ahead of any cars to be started with a time delay.
- 3.6.4 Excessive weaving to warm-up tyres - using more than 50% of the track width and/or falling back in order to accelerate and practice starts, are prohibited.
- 3.6.5 In the event of any starting lights failure the Starter will revert to use of the National Flag.

## 2026 MINI CHALLENGE Trophy Sporting & Technical Regulations

- 3.6.6 Where the lap record at a circuit is less than 1 minute there shall be two Green Signal/Pace Laps. At the discretion of the Clerk of the Course, two Green Signal/Pace laps may be used at other circuits.
- 3.6.7 If a competitor is deemed to have made a false start a 5 second time penalty will be applied

### Rolling Starts

- 3.6.8 Towards the end of the Rolling Lap(s) the pace car will slow in order to bunch up the grid/s and then leave the circuit after extinguishing its roof lights indicating a start is imminent. The pole position driver will then control the pace of the field and the grid will continue at a similar speed on the approach to the start line, keeping a minimum of 2 car lengths to the car in front. The driver in 2<sup>nd</sup> position will be required to keep pace with the pole position driver and broadly in line, each row of cars behind should also remain broadly in line with the driver on the same row so that all cars remain paired. It will not be acceptable to move forward from your row. All cars will start racing when the red start light(s) are extinguished. No overtaking may take place until then.
- 3.6.9 Where there are more than one Class/Championship sharing the grid at the start of the race each Class/Championship pole position driver will be responsible for maintaining a gap of at least 4 car lengths and no more than 10 car lengths behind the back of the grid in front. This will not apply to the driver who is pole in the Class/Championship in the front grid. All other guidance in 3.6.10 will apply to the other Class/Championship.
- 3.6.10 Any cars removed from the grid after the 1-minute stage or driven into the pits on Rolling Lap shall be held in the pit lane. They may start the race after the last car to take the start from the grid has passed the start line or pit lane exit, whichever is the later.
- 3.6.11 Any drivers unable to start the Rolling Lap or start are required to indicate their situation as per current Competition Rules. Any drivers unable to maintain grid positions on the Rolling Lap to the extent that all other cars are ahead of them may complete the Rolling Lap. They MUST remain at the rear of the last row of the grid but ahead of any cars to be started with a time delay.
- 3.6.14 Aborted Start:

If the start is aborted prior to the pace car pulling off, the pace car will not extinguish its roof lights and will continue to lead the field around the circuit for an additional lap and a new start will be attempted. The race will not start until the pace car pulls off the circuit, the signal to start will not be given, and the start lights may remain at red. When this signal is given, all cars must exercise extreme caution and return slowly round the circuit maintaining their original grid positions stopping on the grid. The race start countdown procedure will then be repeated from the one-minute countdown point. At the discretion of the Clerk of the Course, the race distance may be reduced accordingly.

### Safety Car Starts

- 3.6.15 Safety car starts may also be used at the discretion of the Clerk or the Course in conjunction with NCR Ch.12 App.8 Art.2.16.

### 3.7 RACE STOPS

- 3.7.1 Race Stops will be as per NCR Ch.12 App.6 Art.9.

## 2026 MINI CHALLENGE Trophy Sporting & Technical Regulations

### 3.8 RE-SCRUTINEERING

- 3.8.1 Any vehicle involved in an accident, or having been modified in any way, subsequent to pre-event scrutineering, must be represented to the MOTORSPORT UK Scrutineers for further examination.
- 3.8.2 The Clerk of the Course or Scrutineers may order that a vehicle be re-examined even if this involves stopping a vehicle whilst Practicing, Qualifying or Racing.

### 3.9 PITS AND PIT LANE SAFETY

- 3.9.1 Pits: Drivers and Entrants must ensure that the MOTORSPORT UK, Circuit Management and Organising Club Safety Regulations are complied with at all times.
- 3.9.2 Pit lane: The outer lane or lanes are to be kept unobstructed to allow safe passage of cars at all times. The onus shall be on all drivers to take all due care and drive at minimum speeds in pit lanes.
- 3.9.3 Refuelling may only be carried out in accordance with the current NCR Ch.12 App.11 Art.2, Circuit Management regulations and the SR's or Final Instructions issued for each Circuit/event.
- 3.9.4 Refuelling during qualifying and races is prohibited.
- 3.9.5 The Pit Lane Speed limit will be 48 km/h (30mph) unless otherwise notified. At the Clerk of the Course's discretion a fine of £10 per MPH will be applied should this speed limit be exceeded.

### 3.10 RACE FINISHES

After taking the chequered signal drivers are required to progressively and safely slow down, remain behind any competitors ahead of them, return to the pit lane entrance as instructed, comply with any directions given by Marshals or Officials and to keep their helmets on and harnesses done up while on the circuit or in the pit lane and until arriving in Parc Fermé. No team members are allowed in Parc Fermé unless invited to do so by the Scrutineering team. No equipment (other than firefighting equipment if required) may be passed to the driver in Parc Fermé unless pre-agreed by the Scrutineering team. All personal equipment must continue to be worn or left in the car.

### 3.11 RESULTS

All Practice timesheets, grid sheets and Race Results are to be deemed PROVISIONAL until all vehicles are released by Scrutineers after post-practice/race scrutineering and/or after completion of any judicial or technical procedures. NCR Ch.3 App.6 Art.1.4.

### 3.12 LAP TIMING

- 3.12.1 Use of approved working Timing Transponder is mandatory for all qualifying sessions and races. Replacement and hire units are available through the event timing service supplier and will be at a cost to the competitor. Failure to fit a working transponder may result in times not being recorded. Where there is repeated failure (more than twice) to fit a working transponder during a season, a competitor will be referred to the Clerk of the Course for further penalties.

## 2026 MINI CHALLENGE Trophy Sporting & Technical Regulations

### 3.13 OPERATION OF SAFETY CAR

- 3.13.1 The Safety car will be brought into operation to neutralise a race upon the sole decision of the Clerk of the Course, in accordance with NCR Ch.12 App.8 Art.2.

### 3.14 CLERK OF THE COURSE TO DRIVER COMMUNICATIONS

- 3.14.1 A One-Way Receiver under the control of the Clerk of the Course is mandatory for all Competitors at every event in Qualifying and races. Competitors may purchase a Raceceiver from Total Track or it's nominated supplier. A competitor not wearing a working Raceceiver in qualifying or a race will not be allowed to take their start position until rectified. If the problem is not rectified in time to take up their rightful start position a competitor may start from the pitlane once the Raceceiver is worn and working. The Raceceiver must be connected and working until the driver reaches parc ferme.

Should a competitor fail to wear a working Raceceiver the Championship Coordinator may refer the competitor to the Clerk of the Course for the imposition of potential penalties.

Raceceivers can be purchased from Total Track Ltd.

### 3.15 CARS RECEIVING ASSISTANCE

- 3.15.1 Where a car is only able to re-join the circuit with outside assistance the Clerk of the Course shall have the absolute discretion to decide whether the car may continue the session, or must return to the pits for re-scrutineering, or must withdraw from the session completely. This regulation also applies where there has been a race stop or safety car whether or not caused by the car in question. The decision as to whether the car may continue will be communicated to the driver using the signal system and may be supplemented by use of the Raceceiver.

- 3.15.2 During a race stop in any race, should a car have any minor damage to it that can be repaired by hand or by tape, the Championship Eligibility Scrutineer and Clerk of the Course can authorise one team personnel onto the grid to fix the damage under safety grounds.

Should there be any reason this cannot be fixed by hand or tape to the satisfaction of the Motorsport UK Scrutineer the car will be directed off the grid to be worked on in the pitlane but will be a pitlane starter for the restart of the race.

### 3.16 RACE WITH RESPECT

- 3.16.1 By registering for the Championship all competitors and their associates commit to positively promote and demonstrate the Motorsport UK's Respect Code which is appended to these regulations (Appendix D).

- 3.16.2 Where any reports of disrespectful conduct are judged to be well founded the Championship organisers may issue warnings or require remedial actions and/or report the matter to the Championship Stewards who may impose appropriate penalties which can include loss of Championship points and/or Disqualification from further participation in the Championship. NCR Ch.2 App.2 Art.4.1 Refers.

- 3.16.3. It is imperative that we promote the safety and wellbeing of young people and adults at risk. In addition to this all participants must be aware of their behaviour and conduct at all times and abusive language and harmful behaviour will not be tolerated. Any such

## 2026 MINI CHALLENGE Trophy Sporting & Technical Regulations

incidents must be reported to the Championship Coordinator and/or Safeguarding Officer who will also relay the report to Motorsport UK. Details of the Motorsport UK Policies and Guidelines are available at [www.motorsportuk.org/resource-centre](http://www.motorsportuk.org/resource-centre) by selecting Policies and Guidelines.

### 4. PENALTIES

#### 4.1 INFRINGEMENTS

##### 4.1.1 Technical infringements arising from post Qualifying Scrutineering or Judicial Action:

Disqualification must be imposed unless there are exceptional reasons. NCR Ch.2 App.8 Art.1.24 Applies.

##### 4.1.2 Arising from post event scrutineering or Judicial Action:

Minimum Penalty as per the provisions of NCR Ch.2 App.8 Art.2.1 c.

For infringements deemed to be of a more serious nature the Clerk of the Course and/or Stewards of the event are to invoke the provisions of NCR Ch.2 App.8 Art.2.5.

##### 4.1.3 Deliberate or repeated Technical Infringements will be referred to the Championship Stewards for consideration of Disqualification from further participation in the Championship, of the Car, Driver or Entrant.

##### 4.1.4 Infringements of non-technical National Competition Rules or the Sporting Regulations issued for the CHALLENGE in accordance with the current National Competition Judicial Procedure Rules; any such penalties may affect a competitor's eligibility for points and awards.

#### 4.2. DRIVING STANDARDS AND PENALTIES

##### 4.2.1 To maintain standards of conduct, MOTORSPORT UK and Championship officials will monitor race officials and observers reports for adverse behaviour at race events. Any adverse reports could lead to official MOTORSPORT UK action in accordance with the Judicial Procedure detailed in current National Competition Rules plus the following:

##### 4.2.2 Any Competitor who is penalised during an Event and as a result receives an allocation of penalty points on their race licence in accordance with National Competition Rules will receive a grid slot penalty at the next race for the Championship at which they compete. The individual grid slot penalty will depend on the severity of the penalty imposed in accordance with NCR Chapter 2.

- i) Verbal warning – 0 points

Where a driver receives 3 x verbal warnings during the season they will receive a 10 place grid penalty in the next race. If a driver receives further verbal warnings they receive a further 10 place grid penalty in the next race each time the total reaches another 3 x verbal warnings.

- ii) Formal written reprimand – 2 points, 2 place grid penalty

- iii) Fine, time or grid place penalty – 3 points & 3 place grid penalty

## 2026 MINI CHALLENGE Trophy Sporting & Technical Regulations

(For the avoidance of doubt, in the event that a grid place penalty of, say, 5 places is given this will incur 3 penalty points on the licence. Accordingly the actual number of grid places dropped will be 8).

- iv) Disqualification from Qualifying – 4 points
- v) Disqualification from Race – 4 points & a 10 place grid penalty
- vi) Disqualification from the event – 6 points & a 10 place grid penalty

Any grid penalty will mean that a competitor will be moved back the appropriate number of grid slot places from their grid position. For the avoidance of doubt, if the offence occurs in the final round of the Championship the penalty detailed below will apply.

If the offence occurs in the final round of the season, a time penalty of up to a maximum of 30 seconds will be added to the elapsed race time of the competitor."

Any Competitor found guilty of contravening these Regulations (Sporting or Technical) may be reported to the Stewards of the Championship for the possible imposition of further penalties which may be imposed separately or combined at the discretion of the Championship Stewards and may include the following.

- a) A financial penalty of up to £1,045
- b) The loss of Championship points, up to a maximum of 36 (thirty-six) points even if this penalty results in a negative points total
- c) Disqualification from further participation in the Championship

Competitors will also receive Championship points penalties as follows:

First 6 points on licence during season, 0 Championship point deduction per point on licence

Any further points on licence during season, 20 Championship points deduction per point on licence

For the avoidance of doubt.

- 1 licence point = 0 Championship points deduction in total
- 2 points = 0 points Championship points deduction in total
- 3 points = 0 points Championship points deduction in total
- 4 points = 0 points Championship points deduction in total
- 5 points = 0 points Championship points deduction in total
- 6 points - 0 points Championship points deduction in total
- 7 points = 20 points Championship points deduction in total
- 8 points = 40 points Championship points deduction in total
- 9 points = 60 points Championship points deduction in total
- 10 points = 80 points Championship points deduction in total
- 11 points = 100 points Championship points deduction in total
- 12 Points = 120 points Championship points deduction in total

- 4.2.3 Breaches of driving standards will be dealt with firmly. If the Clerk of the Course wishes to view video evidence from the nominated TV Company, on-board judicial cameras, circuit cameras and/or data-logged evidence in order to assist with their enquiry into a breach of driving standards, they may order that the results will remain provisional until all judicial and appeal times have been concluded. The use of video evidence

## 2026 MINI CHALLENGE Trophy Sporting & Technical Regulations

and/or data-logging evidence in all circumstances is at the sole discretion of the Clerk of the Course.

The Championship Organisers may also, within 7 days of the Event, be entitled to request the Clerk of the Course, or the Championship Stewards, to enquire into any matter, notwithstanding that the Clerk of the Course and/or the Stewards of the event may or may not have already investigated the incident. The Clerk of the Course or Championship Stewards will be empowered to take further action if they deem it necessary in accordance with the above. See SR4.2.2 for penalties.

Grid penalties can be applied to any subsequent race start, and if the offence occurs at a round of the final event of the published calendar, a time penalty of up to a maximum of 30 seconds can be added to the elapsed race time of the competitor.

- 4.2.4 Competitors who claim to have received clarifications or rulings on the Championship Regulations must be able to produce on demand written confirmation of such rulings.

Only Championship Stewards are empowered to make rulings on MINI CHALLENGE Trophy Regulations.

- 4.2.5 The Championship Coordinator may request the Championship Stewards to hold a hearing into any alleged breach of the Regulations for further penalties including but not limited to disqualification from further participation in the Championship.

- 4.2.6 In addition to any penalty provided for by MOTORSPORT UK National Competition rules, the Clerk of the Course may, entirely at their discretion, apply one or more of the following penalties to any competitor for causing red signal/session stoppage or Safety car in any qualifying session or race, where the cause was due to driver error by the competitor:

- a) A Reprimand
- b) Fine of up to £1,045
- c) Time Penalty
- d) Grid Place Penalty
- e) Disqualification from the Race
- f) Disqualification from the event

The severity of the penalty shall be entirely at the discretion of the Clerk of the Course and shall take account of the circumstances surrounding the cause of the red signal/stoppage or safety car and take account of any previous similar offences.

For the avoidance of doubt, these penalties may be awarded to the competitor who caused the red signal/stoppage/safety car, or a competitor who caused an incident which in turn caused the session stoppage/safety car.

## 2026 MINI CHALLENGE Trophy Sporting & Technical Regulations

### 5. MINI CHALLENGE Trophy Technical Regulations

#### 5.1 INTRODUCTION

5.1.1 **The following Technical Regulations are set out in accordance with the MOTORSPORT UK specified format and it must be clearly understood that if the following texts do not clearly specify that you can make a modification you must work on the principle that you cannot.**

5.1.2 Cars must comply with the Technical Regulations published by the Organisers and Promoters for The MINI CHALLENGE Trophy throughout official practice, qualifying and events.

5.1.3 Standard: The word 'standard' used within these technical regulations as a description of components is to be interpreted as per 'Standard Part' defined in Chapter 1 Appendix 1 Nomenclature & definitions in the current National Competition Rules.

Specified components from the manufacturer (MINI/BMW) and MINI CHALLENGE parts list are not permitted to be modified beyond the repair or adjustment processes specified by the manufacturer.

Checking of eligibility of all parts will be by comparison to parts supplied by Total Track Ltd from the MINI CHALLENGE Parts Shop. This applies when a part number is displayed on the part or where the part does not have a part number displayed. Entrants should check parts used are eligible by comparing to parts in the MINI CHALLENGE Parts Shop.

5.1.4 Unless specified otherwise, the following regulations apply.

5.1.5 Scrutineering Protocol:

5.1.5.1 The Championship Organisers will appoint a permanent Eligibility Scrutineer who, with their Team, will be responsible for the scrutineering of the vehicles for the qualifying sessions and races of the Championship. In addition Factory Sealed parts may be subject to inspection by Total Track Ltd or an entity, or person nominated by them and shall be subject to chain of custody principles managed by the Championship Eligibility Scrutineer in the event the part to be inspected is removed from the car. SRs 1.1.2, 1.1.2.1 and 1.1.2.2 apply.

5.1.5.2 For scrutineering, the Entrant / Driver must present the competing vehicle and mandatory Entrant / Driver safety equipment. The vehicle must be submitted as used in the Championship and must correspond to all applicable Technical Regulations.

5.1.5.3 A completed log book for each vehicle must be correctly submitted, unless the Eligibility Scrutineer requests otherwise.

5.1.5.4 Aside from the Eligibility Scrutineer, the vehicles may also be subject to eligibility scrutineering during and after the Event. Vehicles will be selected at the sole discretion of the Eligibility Scrutineer and/or their nominated representative. The Eligibility Scrutineer and / or their nominated representative will make random checks in addition to scheduled scrutineering checks for vehicle eligibility throughout Events. Any infringement will be subject to a report to the Clerk of the Course.

5.1.5.5 Entrants/Drivers must comply with the directives of the Eligibility Scrutineer and/or their nominated representative in respect of scrutineering and of re-scrutineering after the Event.

## **2026 MINI CHALLENGE Trophy Sporting & Technical Regulations**

5.1.5.6 After each qualifying session and race the vehicles must be presented directly for scrutineering. Any area deemed necessary by the Eligibility Scrutineer and / or their nominated representative will be subject to Parc Fermé conditions with no exceptions. This will include the track from the Finish Line to the scrutineering area, the waiting area in front as well as the track from the scrutineering area to Parc Fermé, but all areas may be used if necessary.

5.1.5.7 Public and Team personnel must not enter Parc Fermé unless invited by the Eligibility / Safety Scrutineer and/or their nominated representative. Should unauthorised Team personnel be present in these areas, they render their car liable to disqualification from the qualifying session or race. Any breach to Parc Fermé regs will be reported to the Clerk who may impose penalties as appropriate. At their discretion the Clerk of the Course or Organisers may assign other penalties to any driver / Team breaching Parc Fermé regulations. On request of the Eligibility / Safety Scrutineer, the Parent or Legal Guardian of the driver will be permitted in Parc Fermé.

5.1.5.8 Cars may be held in Parc Fermé for a minimum of 20 (twenty) minutes after each qualifying session and race until released by the Eligibility / Safety Scrutineer.

5.1.5.9 At any time the Championship Organisers reserve the right to scrutineer any component or vehicle in the presence of the permanent Eligibility / Safety Scrutineer and one other scrutineer at the Total Track Ltd's workshop or at a service partners premises. An invited member of the Team may also be present. Removal of components from the car may be required at the Event or at the Total Track Ltd's workshop or another location at the discretion of the Eligibility / Safety Scrutineer. After thorough scrutineering of the parts, the result will be submitted to the Clerk of the Course.

5.1.5.10 In the case of a breach of the Technical Regulations or a breach of the procedure surrounding the Technical Regulations, any costs associated with scrutineering and/or eligibility inspections (including, but not limited to transportation, checks, inspections, rebuilds, etc.) will be the sole responsibility of the Entrant.

5.1.5.11 The assembly and dismantling of the vehicle(s) is solely the responsibility of the Entrant(s). Reimbursement of expenses for these measures may not be claimed. Exceptions to this may include appeal / protest according to NCR Ch.2 App.9 Art.2.

5.1.5.12 The Championship Organisers may nominate a chassis dyno that may be used to assist the Eligibility Scrutineer. At any time the Championship Organisers or Eligibility Scrutineer reserve the right to test a vehicle on the chassis dyno machine and may use any data from the dyno machine as guidance and to assist with their determination of eligibility. Competitors / entrants must sign any associated indemnities to allow their car to be tested on the dyno.

5.1.5.13 In the event of a car being dyno tested after a qualifying session or race the driver/Team will be informed by the Eligibility Scrutineer. The car must then be left in Parc Fermé until it is collected by a designated Total Track Ltd official.

## **5.2 GENERAL DESCRIPTION**

5.2.1 The MINI CHALLENGE Trophy Cooper Class is open to vehicles complying with the following regulations.

Cooper Class MINI cars that have been approved and appropriately sealed by the Organisers. The Organisers reserve the right to equalise performance of any invitation car, for example by the addition of ballast or modifying electronic control parameters.

## 2026 MINI CHALLENGE Trophy Sporting & Technical Regulations

The Organisers also reserve the right to allow modifications to facilitate the use of cars by drivers with disabilities.

The organisers reserve the right to add additional wiring or alternative parts to any car at any time for the purposes of allowing the competitor to take part when they would otherwise not be able to participate due to limited or unavailability of parts. The organisers also reserve the right to add additional wiring or alternative parts to any car at any time for the purposes of scrutineering checks or development of new parts.

- 5.2.2 The Championship Organisers, promoters, sporting & technical team are not responsible for the ongoing preparation of the competition car. They are present to give advice only on sporting & technical matters.

The responsibility for the preparation, maintenance & compliance of the car, throughout the event, rests entirely with the Competitor. All cars must be maintained to a high standard and presented in a clean condition, so as not to bring the Championship into disrepute and to ensure that new evidence of contact between cars can be easily seen.

- 5.2.3 All Technical reports, post event summaries, bulletins and regulation amendments or additions will be posted electronically. It is the competitor's/entrant's responsibility to monitor communications.
- 5.2.4 Bulletins will be issued in accordance with NCR Ch.3 App.10 Art.4.1d.

### 5.3 SAFETY REQUIREMENTS

- 5.3.1 MOTORSPORT UK Safety Regulations apply as relevant.
- 5.3.2 Throughout any competition, practice, qualifying or event, drivers must wear flame resistant overalls (covering arms, legs and the torso to the neck) gloves and shoes.

together with a helmet, all of which must comply with NCR Ch.12 App.12 Art.3. It is a mandatory requirement that flame resistant balaclava, socks, and underwear are worn. The use of a FIA homologated Frontal Head Restraint (FHR) device is mandatory.

- 5.3.3 Events held abroad may require mandatory use of current FIA homologated safety equipment e.g. overalls, helmet, FHR device, harness, seat.
- 5.3.4 Bolt in FIA approved roll cage's, part no's MC515-S or MC515-X, or MOTORSPORT UK Approved roll cage MC515.1 may also be welded to the bodyshell at its mounting feet, provided the bolt fixings remain in place. The roll cage must display a MINI CHALLENGE hologram sticker to confirm it has been sourced via the Championship as it is a Championship part. MC515-X will be the primary version supplied, with MC515-S available as an alternative option. TOCA Lifting Clamps MC515L or MC515.1L must also be fitted.
- 5.3.5 MINI CHALLENGE Trophy Spec Rain Light Championship part number MC518 is mandatory and must be fitted in the rear screen where the wiper is normally fitted, using a suitable clamp arrangement taking care not to over tighten.

The wiper must be removed to facilitate fitting. Power should be taken from the OE fog light wiring loom.

- 5.3.6 MINI CHALLENGE Trophy Spec Fuel Tank Shield Kit Championship part number MCR50202104V1 or MCR50202104V2 must be fitted.

## 2026 MINI CHALLENGE Trophy Sporting & Technical Regulations

### 5.4 GENERAL TECHNICAL REQUIREMENTS AND EXCEPTIONS

- 5.4.1 Eligible Cars are all MINI Cooper Class cars approved by the Organisers as 'Cooper Class' cars. No other cars are eligible. No modifications are permitted except as specified hereafter.
- 5.4.2 Notwithstanding these Technical Regulations it is the Competitors responsibility to ensure their car complies with C.7 and Ch.12 App.13 as appropriate and the Supplementary Regulations of any event.
- 5.4.3 The use of non-MINI R50 or MINI CHALLENGE Trophy parts is prohibited unless approved by the Organisers or otherwise specifically stated in these regulations.
- 5.4.4 The Championship Organisers or Scrutineers may seal any part at any time and where this is done the Championship may arrange for sealed parts to be checked at any time until 30 days after the end of the season and shall not be limited to undertake checks within 30 days of the sealing taking place.

### 5.5 CHASSIS

The chassis must remain to the standard BMW MINI specification in construction and material. Reinforcing, removing or adding material to the chassis is not permitted unless otherwise specifically allowed in these regulations. Only R50 and R53 specification shells may be used. For the avoidance of doubt only the R53 shell may be used, not the R53 bonnet, anti-roll bars, or any other R53 part not specifically allowed in these regulations.

The following exceptions are allowed:

All original 'spot" welded seams attaching both front chassis legs to the bulkhead and both front suspension turrets may be 'stitch" welded; this is defined by approx. 25-30mm of weld then 25-30mm gap of no welding. 'Seam" welding, continuous welding along the seam, is not permitted.

When using an R53 shell, with prior written permission from the Championship Scrutineer, it is permitted to remove the battery tray in the boot and replace with a welded flat sheet of steel (at least the same thickness as the OE shell material), to close the opening.

### 5.6 BODYWORK

- 5.6.1 General: The body must be standard in all respects and must not be modified unless otherwise stated below.
- 5.6.2 Interior:
  - a) The driver's seat must be changed to any current or previously FIA homologated competition seat. and may be used whether in date or not.
  - b) All airbags must be removed.
  - c) Steering wheel – Free - Note Ch.7 App.2 Art.11
  - d) It is permitted for throttle, brake and clutch pedal extensions to be added to aid foot control provided this does not enhance performance.
  - e) It is mandatory to fit a plumbed in fire extinguisher that complies with the National Competition Rules Chapter 7, Appendix 6. There are currently two FIA homologation standards: Fire Extinguishers Systems in Competition Cars {1999} and FIA Standard 8865-2015. All extinguishers must be serviced as per manufacturer's instructions.

## 2026 MINI CHALLENGE Trophy Sporting & Technical Regulations

The extinguisher bottle must be mounted on the left hand side rear of the boot space or at the rear of the front passenger seat well, directly in front of the rear seat bulkhead.

f) It is permitted to remove under bonnet sound deadening trim.

g) It is permitted to;

Remove all seats, carpet, headlining, rear trim panels, B post panels, C posts panels, door panels, sill trims, glovebox door, centre console handbrake trim, all audio speakers, sound deadening panels, all airbags and the airbag control unit.

Reroute rear LH and RH wiring through inner wings (modify wiring as required).

Remove rear seatbelt brackets from the body shell.

Remove curtain airbag brackets and handle brackets from the roof panel.

Reposition BC1 unit in LH footwell.

Remove unused seats and seat and loom fittings.

Remove centre tunnel trims.

If original door cards are removed, replacement door cards made of a suitable material must be fitted.

h) Heater and controls must remain fitted and working.

i) The use of additional or alternative interior mirrors is allowed.

j) The use of window nets is strongly recommended.

k) The use of clear film attached to the inside of window glass is optional for all windows except the front screen. It is permitted to fit clear film to the exterior of the windscreen.

l) It is permitted to fit an aluminium foot plate and rests.

m) It is permitted to fit a replacement gear stick knob.

n) It is permitted to fit an internal brake light that can be seen by in-car cameras to show when brakes are being used, where fitted it must operate when the OE brake lights operate.

o) It is permitted to fit a switch and wiring to enable manual operation of the engine bay main cooling fan. Any system must be isolated when the main isolator switch is operated.

- 5.6.3 Ground Clearance: The minimum ride height will be measured in a designated area with the driver normally seated, and with all safety clothing / equipment in place. The ride height measuring area will be communicated to competitors when they sign in or as soon as possible thereafter. The ride height area will be marked to show the required position of the car.

Ride heights will be checked at the tyre pressures as they are sat in Parc Ferme with a minimum pressure of 25 PSI as checked/set by Goodyear. If pressures are less than 25 PSI competitors will be allowed to add air to increase pressure to 25 PSI as checked/set by Goodyear, if a tyre will not hold pressure it may be replaced with another tyre of the same specification and set to 25 PSI by Goodyear.

Minimum ride height figures;

Front 235mm

Rear 275mm

Datums shown below, these will be measured to the centre of the shutlines.

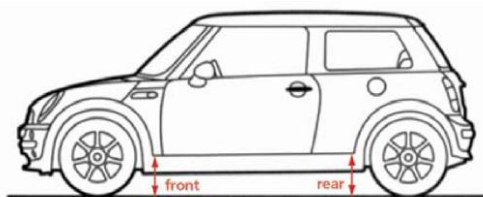

## 2026 MINI CHALLENGE Trophy Sporting & Technical Regulations

### 5.6.4 Exterior:

No modifications from the standard 'Cooper' Class MINI other than:

- a) The fitting of front and rear Crash Bars with integrated steel towing eyes, Championship Part No's MCR50202102F and MCR50202102R, complying with National Competition Rule Ch.12 App.13 Art.1 (1.3) is mandatory.
- b) The addition of Bonnet Catches/Pins is mandatory whilst the addition of Tailgate Catches/Pins is optional. Bonnet Pins Championship Part No. MCF56004 and Front Bonnet Mounts Championship Part No. MCF56056F are available for this purpose.
- c) Cooper Class front and rear Bumpers, Sills and Grilles – any production MINI R50/R53 model profile is permitted except for GP model profiles which are not permitted. The front bumper & bonnet grilles may be from R50/R53 and must be finished/painted in black, no chrome parts are allowed. Pattern bumpers and sills are allowed but must match production items in fit, form & function. Pattern OR aftermarket bonnet and bumper grilles may be used, but must be fitted in the same location as the genuine parts.
- d) Cooper Class Rear Wing (Part No MCR50201302.1) is mandatory.
- e) Headlamps Blanks (Part No MCR50201401) may be used.
- f) It is permitted to use bolts or cable ties to secure trims however no taping of joints is permitted unless prior approval has been gained from the scrutineer to use tape as a means of repairs between races.
- g) Any fitted glass windscreen or window should conform to NCR Ch.12 App.13 Art.2.
- h) Pattern body panels made of ferrous metals or genuine BMW MINI body panels may be used.
- i) Front indicators may be removed and replaced with facias/blanks that fully close the aperture as long as they are made of a solid material, taping of apertures as a blank is not acceptable.

The Chief scrutineer or eligibility scrutineer at the event will make any final decision of the suitability or condition of any damage visible on any fitted glass screen or window at any time during an event.

- 5.6.4.1 MINI Bonnet Badge, BMW/MINI Part No.51147026184, and MINI Tailgate Badge, BMW/MINI Part No.51147026186, are both required to be fitted at all times in the original position.

## 5.7 ENGINE

- 5.7.1 Engines may be sealed by the Championship Organisers at anytime and where this is done the Championship may arrange for sealed parts to be checked at any time until 30 days after the end of the season and shall not be limited to undertake checks within 30 days of the sealing taking place.

Only the 'Cooper' Class engines from BMW R50 Petrol MINI Coopers may be used.

All engine components must remain standard as supplied by BMW MINI for the R50 Engine. Exceptions to this rule are detailed below; if it does not state that a substitute can be used or a machining operation can be carried out then it is not permitted.

It is permitted to use pattern head bolts, cylinder head gaskets and seals, timing chain kits, main bearings, big end bearings and crankshaft harmonic damper pulleys so long as they are a direct replacement for the original equipment part, do not increase the

## **2026 MINI CHALLENGE Trophy Sporting & Technical Regulations**

engine performance in any way, will be dimensionally within +/- 1% of the original BMW MINI part and are manufactured from the same material as the original BMW MINI part.

Main bearing bolts may be replaced with aftermarket High Tensile M10 Cap Head bolts with hardened washers.

The minimum compressed cylinder head gasket thickness permitted is 0.50mm.

### **Cylinder Head**

Only BMW MINI Cylinder Head Part No. 11127508536 is permitted. For avoidance of doubt the JCW variant is not permitted.

It is permitted to use BMW Mini Part No. 11347513019 Inlet Valve as this is used across R50 and R53 Engines.

It is permitted to use BMW Mini Part No. 11347513024 Exhaust Valve as this is used across R50 and R53 Engines.

It is permitted as a means of repair to reface the cylinder head so long as the minimum combustion chamber volume set out in these regulations is observed.

The minimum combustion chamber volume allowed is 30.0cc.

It is permitted to replace/reface the valve seats so long as the original seat profile and position remains.

It is permitted to replace valve guides so long as the original factory position remains.

It is permitted as a means of repair to fit thin wall valve guide sleeves to the original valve guides so long as the factory position of the valve guide and valve is not affected.

The removal or addition of material from the ports or combustion chamber in any form is prohibited.

### **Cylinder Block**

It is permitted to reface the cylinder block so long as piston height regulations set out in this section are observed.

When using original pistons the minimum piston depth from the cylinder block head face is 1.10mm at TDC.

It is permitted, as a means of repair, to replace damaged cylinder bores with cast iron cylinder liners so long as the original factory cylinder bore position remains.

It is permitted to rebore the cylinder block to +0.25mm and use repair piston part No: MC7725. The part number must remain legible.

When using piston part number MC7725 the minimum piston depth from the cylinder block head face is 1.25mm at TDC.

Each piston height will be measured at 4 points from the cylinder block head face at TDC to establish an average measurement that will be the piston height.

## 2026 MINI CHALLENGE Trophy Sporting & Technical Regulations

It is not permitted to machine or alter the pistons in any way, original markings must remain visible on the piston crown.

The Championship may require any car to be tested using the Championship Hub Dyno at any time, for the purpose of observing operation of the engine, logging data relating to the operation of the engine or identifying engine performance which may be abnormal. Dyno results may only be used to help identify a potential breach of regulations, or abnormal operation. Dyno power results themselves may not be used to prove a breach of these regulations.

- 5.7.1.1 It is strictly forbidden for a competitor or their agent to remove or tamper with the MOTORSPORT UK seals or other Championship or supplier seals. Should these seals be damaged or removed for whatever reason except under the direction of the Eligibility Scrutineer the car must not be used in competition or practice until the Eligibility Scrutineer has inspected the engine and refitted the correct seals. The Eligibility Scrutineer may require that the engine be removed and taken to an approved venue to be dismantled for inspection and the cost of this, and subsequent rebuild, will be borne by the competitor.

All instances of broken seals will be logged and reported to the Clerk of Course/Championship Organisers.

Should seals be required to be removed during maintenance, written permission will be required from the Eligibility Scrutineer and a removal number issued. This may be obtained by email to [technical@minichallenge.co.uk](mailto:technical@minichallenge.co.uk) or by contacting the MINI CHALLENGE office. The removed seal must be returned to the Eligibility Scrutineer c/o the MINI CHALLENGE technical official with the seal section intact.

- 5.7.2 Engine management systems:

The ECU of each vehicle is calibrated to MINI CHALLENGE Trophy approved specification for the relevant class. The Championship Organisers, Eligibility Scrutineer or Technical Officers reserve the right to recalibrate or change an ECU at any time during any event.

There can be no recourse upon the Championship Organisers, Eligibility Scrutineer, Technical Officers or MOTORSPORT UK should any ECU, electronic controller or similar unit or system become inoperative during calibration, checking or inspection. The Championship eligibility scrutineer may fit seals to the ECU/Mounting and or Connector.

- 5.7.3 All sensors must be fitted as per manufacturer's specification, functioning and standard, wiring looms must remain standard.

- 5.7.4 Shift Lights – may be fitted.

- 5.7.5 Exhaust System:

MINI CHALLENGE Specification Manifold/Downpipe and Sports CAT part number MCR50202103 must be used.

MINI CHALLENGE Specification Centre Exit CAT Back Exhaust System Championship Part Number MCR50202108 is mandatory.

- 5.7.6 The use of fuel cooling apparatus is forbidden anywhere in the permitted venue.

**2026 MINI CHALLENGE Trophy Sporting  
& Technical Regulations**

- 5.7.7 Spark Plugs: The use of NGK specification Spark Plug BKR6EQUP is mandatory. Both BMW Mini Part No. 12120037608 or NGK BKR6EQUP own brand Spark Plugs are permitted.
- 5.7.8 It is permitted to fit Powerflex Engine Mounting Bush Kit Championship Part No. MC570 & also alternative option Upper Engine Mount Bush Insert Championship Part No. MCR50202107 depending on car age and specification.
- 5.7.9 Engine testing – At any time competitors may be required to make their engines available for testing/inspection, at the competitor’s expense. Technical Bulletins will detail specific requirements.
- 5.7.10 MINI CHALLENGE Air Filter Intake Kit Championship Part Number MCR50202209 is mandatory.

It is permitted to modify the standard air intake piping (BMW/MINI part No.13711477835, item 3 in diagram) to redirect air to the air filter. It is also permitted to remove the Resonator Box (BMW/MINI Part No.13711477842, item 5 in the diagram).

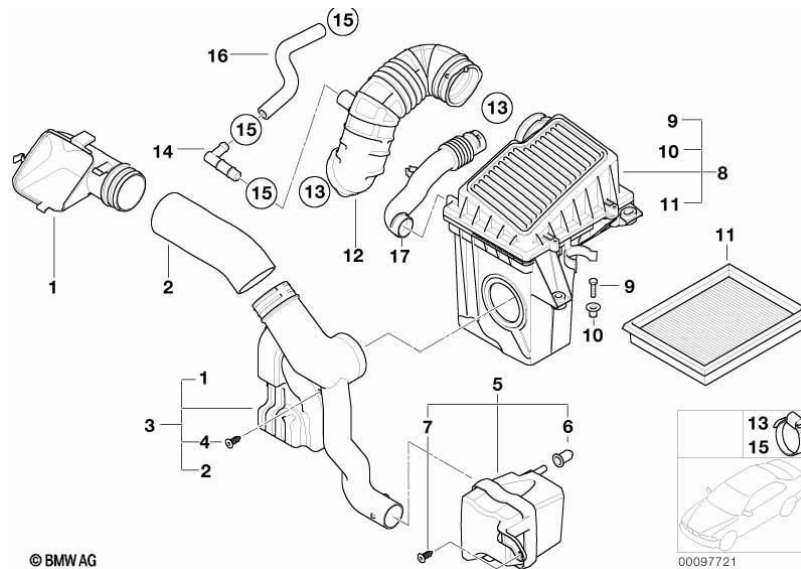

On ‘Cooper’ Class Cars only, it is permitted to drill a maximum of three holes in a specified area of the front panel radiator shroud (BMW MINI Part No. 51711174299/51647200799) for additional cooling to a maximum diameter of 28mm each, this is shown in the square area on the left of the diagram below. There is no limit on the number of holes that can be drilled in the area of the panel that is hatched out on the right of the diagram as long as they are only in the hatched area. Pattern radiator front panels are permitted.

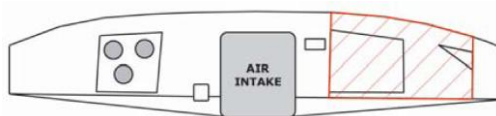

- 5.7.11 Unless stated otherwise elsewhere in these regulations, only genuine BMW MINI engine parts, sensors and ancillaries may be used with the exception of:

The radiator where pattern parts are allowed as long as they fit within the original aperture and are not more than 5% larger or smaller in any dimension.

## 2026 MINI CHALLENGE Trophy Sporting & Technical Regulations

The water pump which must be an exact copy of the original in every way.

- 5.7.12 If the original donor car was fitted with air-conditioning it is permitted to remove the air conditioning pump and radiator.
- 5.7.13 It is mandatory to fit a dry break to facilitate fuel testing.

### 5.8 SUSPENSION

- 5.8.1 It is mandatory to use AST Damper/ & Springs Kit Championship Part No. MCR50201301 along with AST Front Top Mounts Championship Part No. MCR50201301-FTM.

Note: It is permitted to modify the chassis front strut mountings to allow access to the camber adjusting fixing.

Servicing and repairs of Dampers may only be carried out by Total Track Ltd or it's nominated agent.

Upgraded AST Rear Damper Top Mounts Championship Part Number MCR50201301-RTM are optional.

- 5.8.2 It is permitted to fit a front Strut Brace to Cooper class cars, this may only attach to the standard front strut mountings.
- 5.8.3 It is permitted to fit Powerflex Suspension Bush Kit Championship Part No. MC571. Powerflex Rear Control Arm Bushes Championship Part No. MCR50201403-RCA are also permitted.
- 5.8.4 Front camber may be adjusted using the AST Top Mount only.
- 5.8.5 Rear camber adjustment, only by use of standard parts or by using optional Forge Adjustable Rear Control Arms Championship Part No. MCR50202106.
- 5.8.6 Anti-Roll Bars- it is mandatory to use;
- Front – BMW MINI Part No. 31356757072 (diameter 22.5mm +/-1mm)  
Rear – BMW MINI Part No. 33556754818 (diameter 16mm +/-1mm)
- 5.8.7 It is permitted to use Pattern or Genuine BMW MINI suspension and steering parts so long as they are designed to be a direct replacement for the original R50 MINI parts. Pattern Wheel Bearings may also be used.
- 5.8.8 It is permissible to remove/disable the power steering non-return valve.

### 5.9 TRANSMISSION

- 5.9.1 Transmission may be sealed by the Organisers.
- 5.9.2 All gears must be able to be selected and operative at all times.
- 5.9.3 Cooper Class - It is mandatory to use R53 BKD 6 speed gearbox BMW MINI Part No. 23007518632 (or subsequent superseded part numbers) with R53 Cooper S drive shafts, gear change cables, and MINI CHALLENGE Helix clutch kit (Championship Part No. MC766). For the avoidance of doubt, BKE & BKL Gearbox variants are not allowed.

## 2026 MINI CHALLENGE Trophy Sporting & Technical Regulations

All 6 forward gears and 1 reverse gear must be operational.

The overall ratios for forward gears used must be:

First gear -  $50/12 \times 85/31 = 11.42-1$   
Second gear -  $55/21 \times 85/31 = 7.18-1$   
Third gear -  $52/39 \times 85/21 = 5.39-1$   
Fourth gear -  $49/45 \times 85/21 = 4.40-1$   
Fifth gear -  $52/39 \times 85/31 = 3.65-1$   
Sixth gear -  $49/45 \times 85/31 = 2.98-1$

Only MINI CHALLENGE Cooper Class Flywheel Championship part number MCR50202301 may be used. It is permitted as a means of repair to reface a worn Flywheel, but the thickness of the Flywheel in the friction face area must not measure less than 6.5mm at any point, while a maximum of 20g of material may be removed during the refacing process only. Competitors may not remove any additional material or lighten or machine or modify the Flywheel in any other way.

No limited slip or torque biasing differentials are allowed, only the OE open diff for a BKD specification is allowed.

Gearbox internals must also be for BMW MINI Part No. 23007518632 (BKD) and may be inspected at any time.

In all cases the gearbox may be sealed for inspection.

Pattern driveshafts may be used.

It is permitted to fit a CV Joint Gaiter upgrade.

### 5.9.4 DIFFERENTIALS

Limited Slip and Automatic Torque Biasing Differentials are prohibited.

### 5.10 ELECTRICS

- 5.10.1 Battery: the standard battery, or similar, must be fitted and be capable of repetitive starts. Similar means Lead Acid with a physical size within 10% of the original. The Battery must be securely fitted in the original position.
- 5.10.2 Alternator: the standard electrical current generation system must be fitted and working at all times. The correct auxiliary belt length must be used and no lubricants or friction reducing materials can be added to the belt. Audible belt slip will be deemed as non-standard. Correct Belt references are 6PK892 and BMW MINI Part No. 11287526363.
- 5.10.3 Any logged data must be made available to the Eligibility Scrutineer/Championship Technical Director if requested.
- 5.10.4 Isolator Kit: It is mandatory for Battery Isolator Kit, Championship Part No. MC517, to be installed and working at all times.

### 5.11 BRAKES

Permitted Modifications:

## 2026 MINI CHALLENGE Trophy Sporting & Technical Regulations

- 5.11.1 Braided Brake Hose Kits (Championship Part No's.MC170 or MC171) are mandatory. It is permitted to add Brake Hose sleeve to any brake line that is outside the bodyshell.
- 5.11.2 It is permitted to remove stone guards from front disc brakes; it is also permitted to modify those stone guards to act as thermal barriers to protect the ABS sensors and the lower swivel suspension joints.
- 5.11.3 The use of a high boiling point brake fluid such as, but not limited to Sunoco R Extreme, Sunoco R Ultimate or AP Radi-Cal R3 or R4 is recommended. It is strongly recommended that the entire system is flushed before every race weekend and especially after any wet running. It is also strongly recommended that the system is bled after every run.
- 5.11.4 Use of Front Brake Pads (Part No.MCR50201500) and Rear Brake Pads (Part No. MCR50201501) is mandatory.
- 5.11.5 Front Brake Discs MC Part Number MCR50201402 and Rear Brake Discs MCR50201303 are mandatory.
- 5.11.6 It is permitted to fit a brake duct aperture with a frontal area no larger than 200cm<sup>2</sup> and a rounded exit no larger than 6.2cm x 9.6cm. It must be fitted in the front bumper where the original OE Fog Light would have been. MINI CHALLENGE Brake Duct Facias Championship Part No's MC790-LH & MC790-RH are optional to fulfil this purpose.
- 5.11.7 It is permitted to fit brake duct hose with a diameter of no greater than 90mm to direct air towards the brakes. It is also permitted to cut a hole of up to 100mm in each front wheel arch liner in order to allow the brake duct hose to be routed into the wheel well.
- 5.11.8 It is permitted to replace the original external hard wall brake lines with internal or external hard wall brake lines (Copper/Copper Nickel pipe with 3/16" 4.75mm). Brake pipes must be made & routed to a high standard and must not foul on any components.

It is also permitted to replace the original external hard wall brake lines with braided brake lines run through the passenger compartment.

### 5.12 WHEELS

- 5.12.1 15" Rims Championship Part No's MCR50201305 (Team Dynamics Pro Race 1.2) or MCR50201305.1 (Braid) or MCR50201305.2 (Team Dynamics Pro Race LT) are mandatory.
- 5.12.2 It is not permitted to mix two different wheel part numbers across a single axle.
- 5.12.3 Wheel Stud and Nut Kit Championship Part Number MCR50202105 is optional.

### 5.13 TYRES

- 5.13.1 The MINI CHALLENGE Trophy will run control tyres.

COOPER SLICK - Goodyear 185/580R15 GY SLICK 636924 TC 01C3 or 640957 TC 02C3

COOPER WET – Goodyear 185/580R15 or 185/580R15 GY WET 637703/04 TC 02W3 or 640958/59 TC 03W3

a) Other compounds, makes and sizes may be approved for specific circuits, conditions or due to supply issues. Ground clearance limits may also change.

## 2026 MINI CHALLENGE Trophy Sporting & Technical Regulations

- b) The competitor has the choice at all times whether to run both axles with the same specification or one axle with the wet specification and one axle with the slick specification.
- c) Re-cutting, re-grooving or in any other way modifying the tread pattern is not permitted.
- d) All the manufacturers' data must be clearly visible. Buffing of sidewalls to remove data is strictly prohibited.
- e) The use of tyre heating/heat retention devices is prohibited.
- f) The use of tyre modifying treatments, compounds, and inflation with nitrogen or similar gases are all prohibited.
- g) All tyres must be fitted in accordance to the manufacturer's specification.
- h) Tyre scraping may not be carried out within 30 minutes of the start of a session.
- i) The same specification of wet tyre must be used on an axle where wet tyres are used.  
i.e.

Goodyear 185/580R15 GY WET-L TC 03W3 or 185/580R15 GY WET-R TC 03W3 must be used on both the left and right of an axle.

It is permitted to use Goodyear 185/580R15 CR9000 G84W CM404 on the front axle and Goodyear 185/580R15 GY WET TC 02W3 on the rear axle and vice versa.

### 5.13.2 Race Tyres

At the first event a maximum of 8 new or used dry tyres can be nominated.

At the 2<sup>nd</sup>, 3<sup>rd</sup>, 4<sup>th</sup> and 5<sup>th</sup> events competitors may nominate a further 4 new or used race tyres and any 6 previously nominated dry race tyres.

At the 6<sup>th</sup> and 7<sup>th</sup> events competitors may nominate a further 2 new or used race tyres and any 8 previously nominated dry race tyres.

Note - this first event the tyre rule will apply to competitors/guest drivers joining part way through the season.

At the sole discretion of the Championship organisers the number of tyres allowable at each event may be increased at any time. This will be communicated by the Championship Coordinator.

Only in exceptional cases where, in the judgement of the Championship Eligibility Scrutineer, damage to nominated tyres makes further participation in an Event impossible, previously nominated 'used' tyres may be substituted. The substitution may only be authorised by the Championship Eligibility Scrutineer. The selection is to be entirely at the discretion of the Championship Eligibility Scrutineer.

A race event will be deemed to start at the end of the pre-race event test day and finish when the results of the last race have been declared.

There is no restriction on the number of wet tyres used.

The competitor/entrant must submit to the Eligibility Scrutineer, or their appointed deputy, a completed tyre nomination via the means of an electronic tyre app or Championship paper nomination forms prior to the first session under permit for each race weekend.

Should a driver/entrant have an issue with registering tyres in time for a session, they must submit a technical request form to the eligibility scrutineer 30 minutes prior to assembly access.

## 2026 MINI CHALLENGE Trophy Sporting & Technical Regulations

It is the driver's/entrant's responsibility to ensure the correct numbers are recorded.

Turning of tyres will only be done with the agreement of Goodyear and the eligibility scrutineer.

Only dry/slick tyres nominated for the current race event are allowed in the assembly area, pit lane, on track or in parc ferme. For the avoidance of doubt this includes tyres mounted on wheels which are fitted to a car, tyres fitted to spare wheels and tyres that are not fitted to wheels. If tyres which have not been nominated are found to be in the assembly area, pit lane, on track or in parc ferme, the Competitor will be deemed to be in breach of these regulations and referred to the Clerk of the Course.

If it is not possible to identify the owner of a tyre that has not been nominated it will be confiscated with the wheel to which it is fitted and the Organisers will then communicate to all competitors that the tyre/wheel has been confiscated and will be returned once the competitor responsible claims the wheel/tyre and identifies themselves as the owner, at which point they shall be referred to the Clerk of the Course for a breach of this regulation.

If the wheel/tyre is not claimed we will hold the wheel/tyre until the end of the season and if still not claimed it will be auctioned and the proceeds will be donated to the Marshal's charity.

If a barcode becomes illegible during qualifying or a race the tyre will not be permitted to be used in any further sessions or events. The Championship Eligibility Scrutineer may, entirely at their discretion, on presentation of a Technical Query form by a competitor, authorise the use of tyre without a legible barcode on the rear axle only.

- 5.13.3 It is the sole responsibility of the competitor to judge whether the track is wet enough to use treaded tyres on one or both axles.
- 5.13.4 A Competitor may only use tyres they have previously nominated, irrespective of whether they use their own car or any other entrants car at any time on the race event. The only exception is for Competitors joining after the first race event of the season who may at their first event nominate used tyres that have previously been nominated by a different Competitor.

### **5.14 WEIGHTS**

- 5.14.1 Minimum weight for car including Driver and equipment: 1110 kg
- 5.14.2 Any ballast carried must be fitted in the specified position in the front passenger footwell and be securely fixed, with reference to NCR Ch.7 App.2 Art 19.
- 5.14.3 The Organisers will nominate the scales to be used at each venue, these shall be the Scales of Fact. Competitors will be given access to these scales prior to qualifying. It is the competitors responsibility to confirm the scale's position and availability with the CHALLENGE Eligibility Scrutineer.
- 5.14.4 Vehicles may be checked at any time during the event.

### **5.15 FUEL TANK/FUEL**

- 5.15.1 Fuel The use of control fuel is mandatory. Due to the use of control fuel testing can be carried out throughout the season. Control Fuel must be obtained by the Championship

## 2026 MINI CHALLENGE Trophy Sporting & Technical Regulations

approved supplier Sunoco Race Fuels. At the Organisers discretion an alternative supplier may be nominated.

5.15.2 Only permitted fuel as defined by the 2026 National Competition Rules is permitted. For the avoidance of doubt the Championship control fuel is pump fuel as defined by Motorsport UK and no other fuel is allowed to be used whether or not it is defined as pump fuel.

5.15.3 At the end of qualifying and the event at least 3 litres of fuel from the tank of the competing car must be available to the scrutineers for analysis. Compliance with minimum weight specified for the car will be taken before the fuel is removed.

### 5.16 SILENCING

All vehicles must be silenced to current National Competition Rules, and circuit supplementary regulations.

### 5.17 NUMBERS & CHAMPIONSHIP IDENTIFICATION

5.17.1 Both car and Driver must meet the following requirements of the Championship livery during all official testing, qualifying and race events in The MINI CHALLENGE Trophy.

Only the Championship Scrutineer, Championship Coordinator or Clerk of the Course may refer a competitor to the Clerk of the Course for a breach of Regulation 5.17, competitors may not protest a result due to an alleged breach of regulation 5.17.

5.17.2 Championship Sponsors' decals must be carried on all cars, all as supplied and unaltered. The position of Championship decals that may be required to be carried are; front & rear windscreen headers, side & front roof headers, top of front wings, centre of bonnet, front & rear number plates (actual number plates must be used, it is not permitted to attach number plate decals directly to the front bumper or tailgate), both lower doors, both sills, front & rear bumpers, both 'A' pillars, rear wing, driver's name in white text on front & rear screens and both rear quarter panel side windows, passenger side dashboard fascia for driver's name & number, BARC decals on both rear quarter panel side windows.

Advertising may be carried on the rear quarter panel side windows but must allow the correct fitting of driver name and number and BARC decal. The size of these decals must be the same size as those supplied as part of the Championship decal pack at the start of the season.

Competitors are reminded that forward facing competition numbers must be carried in accordance with The National Competition Rules.

5.17.3 Race Numbers must be in accordance with NCR Ch.7 App.10.

NCR Ch.12 App.4 Art.5.7 The numbers for each rear side window, which shall be;

- (i) a minimum of 200mm high
- (ii) with a stroke width of at least 20mm
- (iii) coloured reflective yellow

NCR Ch.12 App.4 Art.5.8. In addition, the windscreen of all cars must display the competition number positioned on the upper area of the passenger's side of the windscreen, as follows;

- (i) the numerals must be at least 150mm high
- (ii) be in the same colour and font as those displayed on the rear side windows

## 2026 MINI CHALLENGE Trophy Sporting & Technical Regulations

(iii) be placed no closer than 50mm from the lower edge of the windscreen “sun-strip” and 50mm from the side edge of the windscreen.

- 5.17.4 Championship Sponsors’ decals. Specific locations on the vehicle are reserved for MINI CHALLENGE sponsors and partners - see diagrams. The specific position of decals will be advised with a diagram when decals are supplied and these positions must be adhered to. Hatched areas are reserved for Championship sponsors and partners. Where a reserved/hatched area is not used at the start of the season competitors may use these areas but they may be used by the Championship at any time during the season. Should this be necessary competitors will be required to remove personal sponsor decals from these areas. Variations to this hatched area decal plan during the season will be communicated via bulletins.

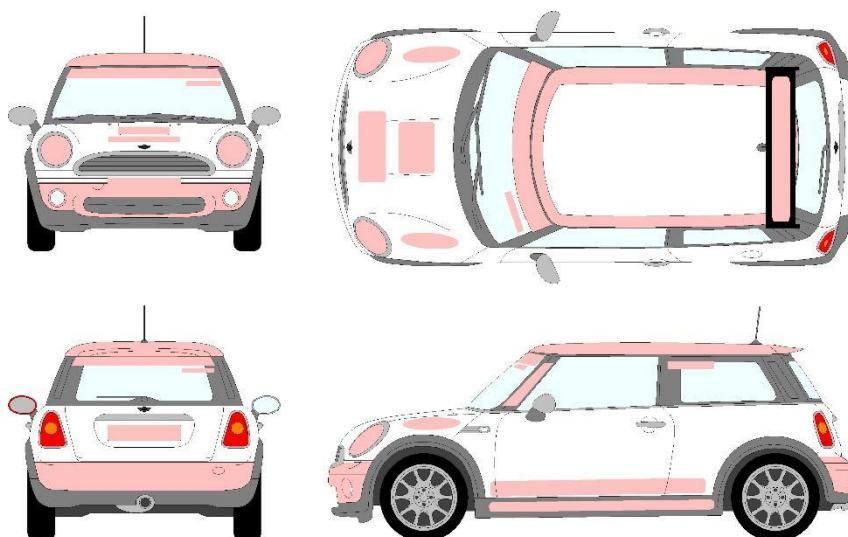

- 5.17.5 To ensure conformity only Competition Numbers purchased from MINI CHALLENGE or its nominated supplier if instructed, will be acceptable. (see also 6.13)

### 5.17.6 Drivers' Names

The Driver's name, as used on the Championship Registration form, must be shown in white on the front and rear screens and both rear quarter panel side windows. The Driver's name and number must also be shown using a decal applied to the Dashboard fascia on the passenger side. All of these decals must remain as supplied and unaltered. Drivers/Entrants may request authorisation from the Championship Coordinator to use a nickname. If authorisation is granted it must be in writing.

Competitors will be provided with a set of Drivers' Name decals at the start of the season. These must be applied to the front and rear screens, both rear quarter panel side windows and the dashboard in positions to be advised in decal pack. No other dashboard decals / logos are permitted to be in view of the Championship on board cameras without prior authorisation in writing from the Championship organisers.

To ensure conformity only Drivers' Names Decals purchased from MINI CHALLENGE, or its nominated supplier if instructed, will be acceptable. (see also 6.13)

## **2026 MINI CHALLENGE Trophy Sporting & Technical Regulations**

5.17.7 If required, drivers race overalls must display Championship and sponsor badges in positions to be defined. If a driver uses overalls displaying a sponsor that conflicts with a

MINI CHALLENGE Trophy sponsor or supplier the Championship Coordinator may at their absolute discretion require that the conflicting sponsors logos are removed.

5.17.8 One set of Championship decals will be issued on completion of registration and payment for registration with the Championship.

Competitors entering after the first event of the season will be required to purchase a set of Championship decals.

Note - Replacement decals can only be purchased from MINI CHALLENGE, or its nominated supplier if instructed. Note the requirement - 6.5.54 Replacement decals will be chargeable to the competitor.

5.17.9 Drivers and teams can be required to display Championship and Championship sponsor, signals, banners and other signage within the paddock. Details will be issued via a Championship Bulletin.

5.17.10 The Organisers reserve the right to sanction an individual livery for a competing car.

### **5.18 DATA LOGGING**

Data logging is permitted.

The Organisers may fit a data logging device to a competing car at any time during an event.

Competitors can purchase their own approved data logger from Appendix C. Any data logging devices fitted to the car must be declared on the Log Book (Appendix E).

However, the data must be made available to the Eligibility Scrutineer and Technical Officers upon request at any time during an event.

It is permitted to connect the data logger to the wiring loom. If the data logger is connected to the CAN Bus it must be declared on the Log Book (Appendix E). The configuration files for any additional data loggers must be made available to the Technical Manager/Director upon request. The eligibility scrutineer reserves the right to check. The Championship Scrutineer may require any logger to be removed at any time.

## **2026 MINI CHALLENGE Trophy Sporting & Technical Regulations**

### **6. COMMERCIAL**

#### **6.1 COMMERCIAL UNDERTAKINGS**

6.1.1 The following Commercial Regulations are contractual between the Entrant and / or Teams and / or Driver and the Organisers and / or Promoters and are not considered by Motorsport UK. Accordingly the application of these Commercial Regulations by the Organisers and / or Promoters will not be subject to the Judicial processes of either the Championship Stewards and / or the Motorsport UK / MSC. However these Commercial Regulations are in the nature of a continuing binding contractual warranty and Regulations given by and on behalf of all Entrants Teams and Competitors in the Championship to the Organisers by the action of applying for and during any current period of Registration and accordingly they are enforceable as such.

6.1.2 All Entrants Teams and Competitors acknowledge, warrant and undertake with the Organisers that any Championship Registration under these Championship Regulations may be suspended, withdrawn or revoked by the Organisers for any breach of these Championship Regulations including but not exclusively these Commercial Regulations. Such suspension withdrawal or revocation of Registration except as provided herein shall not serve in the nature of any liquidated damages or penalty for breach of the contract that is represented by the Championship Regulations and the Organisers are at liberty to seek such remedy and in such forum as they may in their absolute discretion deem appropriate.

#### **6.2 COMMERCIAL REGULATIONS**

6.2.1 The Race event comprising the Championship shall be conducted in accordance with the Regulations, the Organising Club Standing Regulations, the Organising Club Health and Safety and these Commercial Regulations.

6.2.2 In these Commercial Regulations the nomenclature definitions and abbreviations specified in the National Competition Rules of the Motorsport UK from time to time and in the Sporting Regulations of these Championship Regulations shall be adopted.

6.2.3 The Organisers acting through the Championship Organisers have the right to amend, vary or add to the Commercial Regulations from time to time. Such amendments variations and additions shall be notified by bulletin to all Championship Registrants by posting to the address detailed on the Championship Registration Form or sending to the e-mail address detailed on the Championship Registration Form or delivery to the competitor by hand.

6.2.4 All Competitors Entrants Teams and persons associated with them for the purposes of the Championship agree to be bound by the Commercial Regulations and any additions variations or amendments thereto and Competitors Entrants Teams shall procure compliance by persons associated with them.

6.2.5 Any prizes will only be issued to Competitors whose accounts with Total Track Ltd are up to date as at close of business on 8 November following the race season. Any Competitor whose accounts are not up to date as at close of business on 8 November following the race season relinquishes all rights to any prizes.

6.2.6 Enquiries concerning the commercial aspects of the Championship must be addressed to the Championship Coordinator in writing.

## **2026 MINI CHALLENGE Trophy Sporting & Technical Regulations**

- 6.2.7 The Championship title (MINI CHALLENGE Trophy) and associated logo styles may only be used with the prior written approval of the Total Track Ltd.
- 6.2.8 These regulations must not be copied in all or part and are Copyright Total Track 2026.
- 6.2.9 Competitors are advised that, unless requested otherwise, their information will be stored in a computer retrieval system and may be used for publicity purposes.
- 6.2.10 Entry into the Championship is conditional upon each competitor:
- i) Providing free of charge to the Championship Organisers advertising places on their cars and clothing as specified.
  - ii) Accepting without reservation or recourse the surrender of their rights (if any) for TV filming and broadcast of footage collated during the Trophy which may be used at the MINI CHALLENGE Trophy Organisers', Sponsors' and Promoters' discretion.
  - iii) Complying with the Championship Organisers and Sponsors requirements on podium procedures, including a requirement to wear MINI CHALLENGE Trophy Sponsors publicity material in preference to the competitors own sponsor.
  - iv) Co-operating with requests for publicity sessions throughout the season.
- 6.2.11 If an entrant or competitor owes money to the Championship, the Championship organisers may at their discretion refuse to allow an entrant to take part in any event until the outstanding balance is cleared.
- 6.2.12 Should a competitor wish to change Teams from Round 4 onwards, they must seek approval in writing from the Championship Officials.
- 6.2.13 Competitors and Team Entrants must complete the official Motorsport UK and testing administration requirements by the deadlines set by the Championship Organisers. Should a competitor miss a deadline they will be required to make a donation of £50 towards the relevant club Marshall's fund. Non-payment of fines will be referred to the Clerk of the course.

### **6.3 PENALTIES**

- 6.3.1 **WARNING:** The terms of the Commercial Regulations are fundamental to the contract between TOCA (Where applicable) the Organisers and the Registrants respectively. All Entrants Teams and Competitors acknowledge warrant and undertake with the Organisers that any breach of these Championship Regulations including any breach of any of the Commercial Regulations may render the Registrants and any of them ineligible for competition and in such circumstances continued participation in the Championship will be entirely at the discretion of the Organisers who may revoke suspend or withdraw any Registrant. The Organisers as an alternative and/or in addition to revoking suspending or withdrawing the Registration of the Competitor and / or Entrant and / or the Team for participation in the Championship may but subject to their absolute discretion refer the matter to the Championship Stewards in order that if those Stewards see fit they may impose any one or more of the following penalties as a condition of continued participation in the Championship but in respect of such matter there shall be no contractual right of appeal:

## **2026 MINI CHALLENGE Trophy Sporting & Technical Regulations**

Reprimand which may include forfeiture of a qualifying time or times

Time penalty

Disqualification

Forfeiture of Championship points (even if this results in a minus total of points)

In addition or in lieu of any such penalty the Organisers acting through the Championship organisers may require the competitor and/or team to take such steps as may be reasonable to mitigate the damage to the reputation of the Championship and / or the Organisers or any of them.

6.3.2 In the case of an alleged breach of any Commercial Regulation the decision of the Organisers is final as to the culpability and penalty (and for the avoidance of doubt there is no appeal to the Motorsport UK MSC National Court).

6.3.3 A breach of any of the Commercial Regulations may additionally or alternatively result in a fine as contractual liquidated damages up to a maximum of £1000 for each offence being imposed by the Championship organisers. All such liquidated damages must and shall be paid forthwith as a debt to Total Track Ltd and The Championship. Championship Registration will be suspended until such payment has been received. A serious or continual breach of any of the Commercial Undertakings may render the Entrant/Driver ineligible for competition, in which case, participation in the Championship by that Entrant/Driver will be entirely at the discretion of the Championship organisers.

6.3.4 Where in the opinion of the Organisers any Competitor(s) and / or Entrant and / or Team has gained an unfair advantage (whether inadvertently or not) from a breach of the Commercial Regulations by its own actions or those of another Competitor or Team the Organisers acting through the Championship Coordinator may impose any one or more of the penalties set out in Commercial Undertaking 7.3.1 above in order to remove or otherwise compensate for such advantage.

### **6.4 TELEVISION at TOCA EVENTS**

6.4.1 By entering the MINI CHALLENGE Trophy Championship competitors entrants and teams are obliged to assist TOCA and the Organisers in the promotion of the Championship and in particular the television coverage:

6.4.2 All competitors entrants and teams are obliged to assist the TOCA nominated TV Production Company and / or any other nominated Championship TV production company in the filming of Championship events and related activities through the granting of interviews when requested and any other reasonable requests of the TV Production Company or the Organisers.

6.4.3 Drivers finishing first second and third in the Drivers' Championship must make themselves available immediately after each Qualifying session Race and/or the prize giving ceremony for any media interviews in accordance with the requirements and directions of the Organisers.

6.4.4 All cars must carry an in-car camera or on-board camera during testing free practice official qualifying sessions and/or the races at the request of the TV Production Company.

6.4.5 Any competitor and/or anyone connected with a competitor is prohibited from trying to influence the editorial decisions of the TV Production Company in connection with the

## **2026 MINI CHALLENGE Trophy Sporting & Technical Regulations**

Championship as it is shown on television or of otherwise interfering with television coverage.

- 6.4.6 The decision as to which car is to carry an on-board camera and/or an in-car camera rests solely with the TV Production Company TOCA and Total Track Ltd whose decision shall be final.
- 6.4.7 It is permitted to install own brackets in a competing car in order to incorporate an in-car camera but is always subject to the prior approval of the Licenced Eligibility Scrutineer and the nominated TV Production Company.
- 6.4.8 The TOCA nominated TV Production Company shall have unrestricted access to any video footage captured by the drivers and / or teams or their associates and may incorporate any such material in its coverage of the Championship.
- 6.4.9 All footage obtained or recorded by the TOCA Nominated TV Production Company of the Championship belongs to TOCA and/or the TOCA nominated TV Production Company and all competitors entrants and teams and their associates consent to their images being used by TOCA (and those authorised by it) for promoting the Championship and merchandise associated with the Championship.
- 6.4.10 The MINI CHALLENGE Trophy/Total Track Ltd has exclusive broadcast, cable, satellite, video, internet, social media and mobile phone rights and rights to all other mediums to film and record the participation of the Driver, Entrant, Sponsor, and any other team members in the events and activities throughout the Championship and to licence, assign or otherwise deal with such rights and/or film and recording and distribution.
- 6.4.11 Any Competitor advised by the Championship Organisers that they are to carry on-board television cameras, must have the approved Championship logos on the dashboard, visible to the official on-board camera. The decision for the positioning of these Logos rests solely with the Championship Organisers and Promoters.

No other publicity material visible to an onboard camera will be allowed.

### **6.5 ADVERTISING**

- 6.5.1 No advertising of tobacco or tobacco products is permitted in any shape or form in this Championship. Additionally any products that are not permitted to be advertised on UK television are also prohibited. Advertising of any alcoholic products or associated with gambling must meet the ASA (advertising standards authority). The Championship Organisers reserve the right to censor any advertising, that is deemed to be unsuitable. Any car or driver considered by the Championship Coordinator and / or the Organisers in their absolute discretion to be exhibiting unsuitable advertising may be excluded from any Round of the Championship.
- 6.5.2 If required, drivers race overalls must display Championship and sponsor badges in positions to be defined. If a driver uses overalls displaying a sponsor that conflicts with a MINI CHALLENGE Trophy sponsor or supplier, the Championship Organisers may at their absolute discretion require that the conflicting sponsors logos are removed.
- 6.5.3 At the start of each official session, the cars must be clean and in good order, with all Championship decals in place and in good order.

## **2026 MINI CHALLENGE Trophy Sporting & Technical Regulations**

- 6.5.4 A complete set of Championship decals will be issued to each competitor at the beginning of the season on completion of registration with the Championship. Any subsequent decals required can be purchased through MINI CHALLENGE, or its nominated supplier if instructed.
- 6.5.5 No advertising or statement on the car or on Drivers' race clothing is allowed which may be considered offensive or inflammatory to the Championship Organisers, the Promoters or their Sponsors and individual Event Organisers.
- 6.5.6 No car manufacturer logos may be displayed on race cars, race support vehicles, awnings or race suits other than the MINI Logo. The only exception is for race support vehicles original badges.
- 6.5.7 All Drivers required for Podium Presentations at each event, must attend, without delay. Failure to do so may mean forfeiture of any Championship awards/points at that round. Drivers required for podium presentations are required to remove any signage, decals, badges and hats that are not relevant to, or conflict with, the MINI CHALLENGE Trophy.
- 6.5.8 All competitors undertake not to publish negative or derogatory comments about Total Track Ltd, MINI CHALLENGE Trophy, any MINI CHALLENGE Trophy suppliers or partners including but not limited to MINI, on any website, internet site or system, social media site or any publication or any broadcast media. Any breach of this undertaking will be treated as a breach of these regulations and will be reported to the Championship Stewards to investigate and take action where necessary.

### **6.6 PUBLICITY**

- 6.6.1 At all Championship events Drivers wearing their driving overalls must take part in any autograph session, paddock walkabout and pre-race parade when requested by the Championship Coordinator.
- 6.6.2 All drivers who qualify for an award shall attend the podium ceremony and any post-race televised interviews wearing their race winners caps to be provided by Total Track Ltd. Failure to attend the podium ceremony or failure to attend correctly attired may result in a fine being imposed by the Championship Coordinator.
- 6.6.3 In signing the Championship Registration Form Competitors Entrants and Teams agree that TOCA (and those authorised by it) and the Organisers may make use of their activities and successes in motor sport for any advertising publicity public relations and merchandising purposes. The Competitors Entrants and Teams also agree that in any advertising or promotion with which he/she/it is associated (relating to the Championship) the full title of the Championship (including the Championship sponsors name) will be used at all times.

### **6.7 MERCHANDISING**

- 6.7.1 The Competitor Entrant and Team hereby authorise TOCA and the Organisers to use and reuse and sublicense the use of images and representations of the vehicles competing in the Championship and the name images and representations of the driver the Team the Team logo and Team paraphernalia including (insofar as the same appear on the clothing worn by the competitor or on Team paraphernalia or on the cars driven by the Competitor in the Championship) the logo and decals of all sponsors of the Competitor and/or Entrant and / or Team for the purposes of producing merchandise exploiting the reputation of the Championship and all elements of the Championship.

## **2026 MINI CHALLENGE Trophy Sporting & Technical Regulations**

- 6.7.2 The Competitor Entrant and Team authorise TOCA and the Organisers to use and licence others to use all Championship images and other material relating to the Championship in marketing and packaging material and commercial advertisements exploiting the Championship or merchandise of the Championship or any individual elements of the Championship.
- 6.7.3 The Competitor Entrant and Team shall assist the Organisers and TOCA and those authorised by it with the promotion of the Championship and production and promotion of merchandise associated with the Championship.

### **6.8 EVENT ARRANGEMENTS**

- 6.8.1 Throughout the course of the Championship the Championship Coordinator on behalf of the Organisers may inspect all race transporters and motorhomes to ensure that they are of smart appearance and in good order. The Championship Coordinator may refuse to issue a Paddock vehicle pass to any vehicle that is deemed by the Organisers to be unsuitable for display within the Paddock.
- 6.8.2 At the start of each event practice session and race the competing cars and all Team vehicles must be clean of smart appearance and in good order. The Championship Coordinator and Organisers reserve the right to suspend competitors not meeting this requirement from taking further part in the Championship and withdraw passes until this Regulation is fulfilled to their satisfaction.
- 6.8.3 Any team considered by the Organisers in their absolute discretion to be exhibiting unsuitable advertising may be asked to and shall thereby withdraw it immediately.
- 6.8.4 Any pipes wires or cables trailing from motorhomes and/or transporters and/or generators must be protected by hard covers where they will be crossed by vehicles or pedestrians. All health and safety requirements must be met at all times and warning signs must be erected where there is any danger to the public or other persons.

### **6.9 PADDOCK REGULATIONS**

- 6.9.1 The amount of space requested will not necessarily be the space granted to an Entrant by BTCC who will assess individual requirements at the MINI CHALLENGE Trophy Media Day or their first event if the Entrant did not attend the Media Day or a Media Day did not take place.
- 6.9.2 Each team will be permitted one transporter and awning to be parked in their designated Paddock area. Awnings will only be permitted to run from the side of the transport/truck. This includes on TOCA race weekends and any NON TOCA race weekends.
- Entrants running three or more cars may be permitted additional space for an additional Support Vehicle/flat patch. Awnings are not permitted on Support Vehicles. This includes on TOCA race weekends and any NON TOCA race weekends.
- 6.9.3 Any amendment to the vehicle and/or awning size required must be notified to the BTCC Paddock Team for their approval prior to use on the Monday prior to a race weekend.
- 6.9.4 The space allocated by BTCC is granted for the preparation of race cars and team catering. It is expressly forbidden to use this space as a hospitality area or trade site area.

## 2026 MINI CHALLENGE Trophy Sporting & Technical Regulations

- 6.9.5 No hospitality/entertaining will be allowed by Entrants/Drivers within the Paddock. Teams may use an area at the rear of their awning specifically for team catering only.
- 6.9.6 Motorhomes/caravans and private cars are not permitted within the Paddock at any venue unless in exceptional circumstances and with the prior written approval of the BTCC Championship Co-ordinator. At TOCA weekends, there will be a designated motorhome area at each race event, should you require a motorhome pass this must be requested in writing to your Championship Coordinator prior to the first permitted race weekend. Any additions to this must be communicated to the Championship Coordinator by the Monday prior to the race weekend.
- 6.9.7 Each team will be permitted one transporter and awning to be parked in their designated Paddock area that may contain an area at the rear specifically for team catering. Any Entrant requiring an additional awning must make a request in writing to the Championship Coordinator prior to the event.
- 6.9.8 Only small four-wheeled motorised Paddock vehicles which are authorised by TOCA may be used within the Paddock. These vehicles may only be used during authorised times and when driven by a current full road traffic licence holder for race team related business. Recreational use is strictly prohibited. For the avoidance of doubt all two-wheeled transport is banned from the Paddock. Please note that private cars and vans are not considered as Paddock vehicles. Motorised Paddock vehicles may only be used within the venue during the period from 2 (two) hours prior to the first scheduled track activity until 1 (one) hour after the last track activity on each day of the Event including the Paddock set-up day. There is a total ban on their use outside these times.
- For the avoidance of doubt, bicycles and scooters are not to be used on the paddocks at any times.
- 6.9.9 There is a speed limit of 10mph in the Paddock at each venue. The only movement of race cars permitted in the Paddock is on the way to the Assembly Area and on the way back from Parc Fermé with a current full road traffic licence holder seated in the Driver's position and in control of the car.
- 6.9.10 Tailgates/tailifts on transporters must remain closed at all times except when loading and/or unloading your race cars and at TOCA events may not be used until the times specified in the TOCA Bulletins/Final Instructions.
- 6.9.11 Entrants/Drivers will be issued with a specific time to park up their race transporters in the Paddock at each Event. Access to the Paddock outside your parking-up time is forbidden unless the express written permission of your Championship Coordinator (after consultation with the BTCC Championship Coordinator and/or TOCA Paddock Team) has been obtained to park up at a different time. Verbal permission from circuit employees will not be accepted.
- 6.9.12 When a race transporter is parked in position in the Paddock at an Event it is expressly forbidden to remove it from its Paddock space until after the start of the third BTCC race of an Event unless the express permission of the BTCC Championship Coordinator or their appointed representative has been obtained to remove it earlier. Awnings may not be dismantled until after the start of the second BTCC race of an Event.
- 6.9.13 Hard covers should protect any pipes, wires or cables trailing from motorhomes transporters and/or generators where they will be crossed by pedestrians and/or vehicles.

## **2026 MINI CHALLENGE Trophy Sporting & Technical Regulations**

- 6.9.14 All health and safety regulations as well as any such directives issued by the Championship and/or the venue must be met at all times.
- 6.9.15 It is an offence for any person to ride or drive any motor vehicle on the roads or other public areas under the control of the venue promoters unless they are covered by third party insurance. It is a condition of Registration that such insurance is in place. A copy of the policy must be lodged with the Championship Coordinator before the first Event of the season.
- 6.9.16 The competitor's Entry Fee does not cover the provision of generator power to private motorhomes/caravans or suchlike during an event. Generator power can be provided for such use via TOCA's Official Power Supplier - provided that sufficient competitors book this at least 7 days in advance of each event to warrant a separate generator for such use being provided. NO free-standing generators are permitted, should a competitor or team be reported using a free-standing generator, the TOCA officials will issue paddock fines accordingly.
- 6.9.17 Any competitor or any person or entity associated with a competitor connecting to the TOCA Official Power Supplier's generators without pre-booking or paying upon demand will be immediately disconnected and fined a minimum of £100.
- 6.9.18 A fine of a minimum of £500 may be levied for any infringement of Paddock Regulations contained in these Commercial Regulations at the absolute discretion of the TOCA and/or the Championship Organisers. Each registered Entrant/Driver is responsible for the payment of fines incurred by all vehicles entering the Paddock/Pits on their behalf. The decision of TOCA and/or the Championship Organisers in respect of this additional penalty shall be final with no appeal to the MSC National Court.
- 6.9.19 Teams should refrain from using 'single use plastics' within the paddock area, their garages or awnings, or hospitality areas. In this respect "single-use" is a term which can refer to any plastic item either designed to be used for one time, or likely to be used in that way, within the venue. Such items include disposable single-use plastic bottles of water or drinks, plastic cups, plastic cutlery, plastic straws, thin plastic carrier bags, plastic drink stirrers etc.
- A team which has no practical alternative to the use of a fully recyclable single use plastic item due to an existing commercial partnership, must first submit for approval a comprehensive plan for the collection within the venue and the recycling of those items including providing evidence as to the completion of their recycling after each event.
- 6.9.20 All Paddock vehicles that require personnel to be on the roof (i.e. to affix awnings or flag poles/flags) must have the relevant safety equipment fitted. Any personnel on the roof must wear the relevant safety harnesses which must be affixed to the equipment on the roof.
- 6.9.21 Any team participating in the MINI CHALLENGE Trophy Championship may be required to have each race transporter fitted with a minimum of two flag poles. Teams may fit up to two more additional flag poles per race transporter. Where two flag poles are fitted they must be fitted nearest to the roadway in front of their race transporter.

Prior to the start of the Season, the Championship may supply two flags from the Championship free of charge to each team for each race transporter they operate, which shall be flown on, at least on one flag pole on each transporter and the team may then use the other flag pole to fly a flag of the team entrant. Where more than two flags are fitted to a race transporter the MINI CHALLENGE supplied flags may be both fitted nearest

## 2026 MINI CHALLENGE Trophy Sporting & Technical Regulations

the roadway or diagonally across the race transporter. This ruling will apply to TOCA & NON TOCA Race weekends.

All flags issued must be returned to the Championship Organisers at the end of the final round and be in good order. Failure to return or return in good order will result in the Championship Charging the entrant for replacement flags on a cost recovery basis.

- 6.9.22 Easyup style awnings are not allowed to be used as race car awnings at any TOCA Event, they may only be used at the back of a main awning for use as a tyre area or similar.
- 6.9.23 Race car awnings must be fixed to a rigid or articulated lorry and may not be free-standing.
- 6.9.24 Race car awnings must be fitted out with flooring tiles and garage boards.
- 6.9.25 The Championship Organisers shall have the discretion to require a competitor or entrant to make improvements to the appearance of their paddock set up or refuse entry to the paddock.
- 6.9.26 Only essential Official and Team vehicles will be issued with Paddock vehicle passes.

For the avoidance of doubt, private cars (i.e those with only a Competitors Car Park pass or no pass) are not permitted within the Paddocks.

### 6.10 TIMETABLE REGULATIONS AT TOCA EVENTS

- 6.10.1 Should any Championship have less than 15 (fifteen) registered Drivers at an Event then BTCC reserves the right to re-schedule their race either first or last on the race day timetable at the next Event.
- 6.10.2 BTCC reserves the right to amend the race day timetable at its discretion.
- 9.10.3 Entrants/Drivers should listen carefully to the Paddock tannoy announcements and their Championship Coordinator regarding the time they are required in the Assembly Area. In ideal conditions the timetable may be brought forward and Entrants/Drivers may be called to the Assembly Area earlier than originally scheduled. Entrants/Drivers are warned that they will miss their qualifying session or race if they are not ready in the Assembly Area when the cars are released.

### 6.11 RADIOS AT TOCA EVENTS

- 6.11.1 It is not permitted to use any form of pit to car communication systems during Qualifying and races at any event. Systems will be permitted during Friday free practice and MINI CHALLENGE Trophy test days but all equipment must be removed for Qualifying and races.
- 6.11.2 Radio frequencies used by an Entrant/Driver team member and/or any of their suppliers must be licenced for use in the UK by the appropriate regional office of the Radiocommunications Agency. The Championship Coordinator must be notified prior to the start of the season of the Radio Frequency to be used by the Entrant/Driver team members and/or any of their suppliers. A copy of the Licence or Short-Term Hire Agreement for the frequency must also be submitted. The Championship Coordinator reserves the right to request production of the original Licence/Short Term Hire documentation to verify the use of any frequency by an Entrant/Driver team member and/or any of their suppliers at any time during the season.

## **2026 MINI CHALLENGE Trophy Sporting & Technical Regulations**

- 6.11.3 The Entrant/Driver team member and/or any of their suppliers must at all times comply with the terms and conditions specified from time to time by the Radiocommunications Agency for the use of their radio frequency.
- 6.11.4 In the event that a frequency used by an Entrant/Driver team member and/or any of their suppliers interferes with a frequency used by a local emergency service or other third party the Entrant/Driver team member and/or supplier shall forthwith change its radio frequency to a non-conflicting frequency to the satisfaction of Championship Organisers and in accordance with the requirements and prior approval of the Radiocommunications Agency. The Entrant/Driver team member and/or any of their suppliers will be suspended from qualifying and racing until a change of frequency has been effected and a copy of the approval of the Radiocommunication Agency submitted to the Championship Coordinator.
- 6.11.5 If an Entrant/Driver team member and/or any of their suppliers wish to change their frequency they must first obtain approval from the Radiocommunications Agency and submit a copy of such approval to the Championship Coordinator.
- 6.11.6 It is not permitted to scramble radio speech transmissions or encode them in any way.
- 6.11.7 For the Cooper Class it is mandatory to use a working Raceceiver in all sessions including the pre-race event test day. Should a competitor not have a working Raceceiver fitted during a session or fail to respond to instructions given over the Raceceiver the Championship Coordinator may request that competitors are black signalled.

### **6.12 MISCELLANEOUS**

- 6.12.1 Transponders must be fitted and working on any official test day and race events. Where there is repeated failure, (i.e. more than twice during a season) to fit a working transponder a competitor may be disqualified from the session or required to remain stationary in pit lane for 5 minutes in current or the next test/qualifying session, whereby they may be referred to the Clerk of the Course for further penalties under the race permit.
- 6.12.2 TSL signal Communication System display must be fitted and working on any official TOCA test day and race event. Where there is repeated failure, (i.e. more than twice during a season) to fit a TSL signal Communication System display a competitor may be disqualified from the session or required to remain stationary in pit lane for 5 minutes in current or the next test/qualifying session, whereby they may be referred to the Clerk of the Course for further penalties under the race permit.
- 6.12.3 A One-Way Receiver must be fitted and working on ANY test day and race event. Where there is a failure to fit a One-Way Receiver a competitor may be required to remain stationary in the holding area (assembly) or in pit lane until a One-Way Receiver is in working order and is approved by the Championship Coordinator.
- 6.12.4 An onboard camera must be fitted for the permitted race weekend, must be installed and in working order on ANY test day. Where there is repeated failure (i.e. more than twice during a season) to fit a working on board camera a competitor may be required to remain stationary pit lane for 5 minutes in the next test session, whereby they may be referred to the Clerk of the Course for further penalties under the race permit.
- 6.12.5 Competitors entrants and teams and officials may not either individually or with any such participants or through any representative or agent procure solicit or arrange for any supplies gratuities products merchandise equipment or any other thing of value to be provided from any source whatsoever bearing or depicting any Championship logo and/or

## **2026 MINI CHALLENGE Trophy Sporting & Technical Regulations**

any trademark and/or any copyright and/or any image used or associated with the Championship without the prior written permission of the Championship Coordinator to do so.

- 6.12.6 All images, photographs, recordings or representations of the participation in the Championship or association with the Championship of competitors entrants and teams may only be used for commercial purposes with the prior written consent of the Championship Coordinator. No consent is required for normal media reporting of the Championship.
- 6.12.7 All the broadcast recording cable satellite digital video internet and interactive rights and other rights in all media to the Championship and other related events are the sole property of TOCA. Any recording or broadcast of the Championship and other related events or rebroadcast or reproduction of material without express written permission of the Championship Coordinator is strictly prohibited. Competitors, entrants and teams currently registered in the Championship may subject to the prior written permission of the Championship Organisers and subject to any conditions that they may impose at their absolute discretion be granted rights to use broadcast material for their own specific promotional use within the UK without fee or charge. Rights requested for any other commercial use must be made in writing to the Championship Coordinator and if granted will be subject to Licence which may include a fee or charge.
- 6.12.8 Teams should refrain from using 'single use plastics' within the paddock area and their awnings. In this respect 'single-use' is a term which can refer to any plastic item either designed to be used for one time, or likely to be used in that way, within the venue. Such items include disposable single-use plastic bottles of water or drinks, plastic cups, plastic cutlery, plastic straws, thin plastic carrier bags, plastic drink stirrers etc.

A team which has no practical alternative to the use of a fully recyclable single use plastic item due to an existing commercial partnership, must first submit for approval a comprehensive plan for the collection within the venue and the recycling of those items which will include providing evidence as to the completion of their recycling after each event.

### **6.13 CHAMPIONSHIP LIVERY**

- 6.13.1 Approved MINI CHALLENGE Trophy Championship stickers must be fixed to each competing car during all nominated test days, official testing, (referenced in section 1.5.1) qualifying and race events.
- 6.13.2 All cars must carry the MINI CHALLENGE Trophy Sponsors' decals and panels in the correct locations, without alteration and without interference, in all sessions including the pre-race event test day. Where a car is not carrying the correct decals during a pre-race event test day the Championship Coordinator or Championship Scrutineer may request that the car is black signalled until the correct decals are fitted.
- 6.13.3 All surfaces which have not been reserved by MINI CHALLENGE for Championship Decals are free for use. Conflicting sponsor's stickers must be approved by the Championship Organisers in advance and the position, size and colours (if approved) will be at the discretion of the Championship Organisers.
- 6.13.4 The Championship organisers reserve the right to remove any badges or branding which is deemed to be unsuitable or conflicts with other Championship / MINI CHALLENGE Trophy sponsors.

## 2026 MINI CHALLENGE Trophy Sporting & Technical Regulations

### 6.14 TEAM FILMING / FOOTAGE AT TOCA EVENTS

6.14.1 Teams may only undertake their own 'behind the scenes' filming providing written permission - clarifying what content you wish to film & where you intend to use it (i.e. team website etc.) – is first be obtained from both;

Rhea Beauchamp MINI CHALLENGE TROPHY CHAMPIONSHIP COORDINATOR  
Alan Gow BTCC DIRECTOR  
Hugh Dickinson, ITV Sport Archive and Rights Producer (hugh.dickinson@itv.com)

6.14.2 Media Accreditation via the team must also be applied for from Simon Melluish (simon@smsportsmedia.com),-stating the intention of the person or crew to film video footage not stills photography.

6.14.3 If approved, final accreditation for each event must be applied for by the filming team directly through each circuit. This includes the requirement to sign on with the circuit at each event.

6.14.4 They will issue you with a bib which MUST BE WORN WHEN FILMING or the camera operator will be ejected from the circuit.

6.14.5 ABSOLUTELY NO FILMING IS ALLOWED IN THE PIT-LANE, ON THE GRID IN PARC-FERME, IN THE ASSEMBLY AREA or TOCA TECHNICAL AREA. YOU ARE NOT PERMITTED TO FILM ANY PART OF THE RACES OR ANY MOVING RACE CARS - AT ANY TIME OR FROM ANY LOCATION.

6.14.6 Teams will, subject at all times to the foregoing, be permitted to film in and around paddock areas, spectator and trade areas, transporters, hospitality & motor homes.

6.14.7 Film crews must remain cognisant of the ITV crew who have priority at all times.

6.14.8 Film crews may film the podium but only from behind the ITV crew and not obscure or hinder ITV's filming of the podium.

6.14.9 A positive image of the BTCC/MINI CHALLENGE Trophy and its competitors, sponsors and officials must be portrayed at all times. TOCA and ITV reserve the right to immediately withdraw any permission granted should they deem it preferable and/or necessary to do so.

6.14.10 Any filming or material obtained that goes outside these guidelines will result in the immediate withdrawal of any further permissions to the team for the rest of the season.

### 6.15 ON-BOARD FOOTAGE

6.15.1 Teams may use short clips of video footage from test days, qualifying and races (up to 2 minutes in total) on the following terms:

6.15.2 A complete lap cannot be shown - it must be interspersed with other angles or footage. No more than 30 seconds of continuous footage at any one time can be used.

6.15.3 Any on-board footage containing vision or sound of anything out of the ordinary negative or untoward - particularly regarding another competitor - cannot be used (e.g. another car spinning off or having an incident or mechanical failure etc).

## 2026 MINI CHALLENGE Trophy Sporting & Technical Regulations

### 6.16 ITV FOOTAGE REQUESTS

- 6.16.1 ITV will make available, via Google Drive, a copy of the programme taken from ITV4. This will be available by 6pm on the Monday immediately following each event, in an online-friendly MP4 file with the ITV logo.

Teams and drivers can use the race footage, with race commentary, of up to 30 secs per race from 6pm on the Monday, then up to 5 mins in total from 6pm on the Wednesday, after each event, only on their individual dedicated team/driver/sponsor website or official YouTube site. (Note: UK viewers can watch races in full via ITVX.)

In addition, teams/drivers may also use interviews from the programme that are solely relevant to themselves; i.e. you can only use interviews with your own drivers but not with other drivers or teams.

You may not use any other aspect of the programme (including, but not limited to, presentation, features, edits, music, BTCC races or non- MINI CHALLENGE races etc).

All users will be required to sign an agreement with ITV prior to them granting access to the Google Drive. There is an element of trust, regarding what footage you use, so any user who flouts the above restrictions will have their access revoked.

There will be no charge for access to this footage.

Race footage should no longer be accessed via Cloudbass.

- 6.16.2 Requests for television broadcast use:

Written requests must be made to;

Rhea Beauchamp MINI CHALLENGE TROPHY CHAMPIONSHIP COORDINATOR  
Hugh Dickinson, ITV Sport Archive and Rights Producer ([hugh.dickinson@itv.com](mailto:hugh.dickinson@itv.com))

- 6.16.3 ITV has exclusive UK broadcast rights on all race footage, in all media, for 7 days after each event.

From the 8th day following the event (usually a Monday)

Footage to be broadcast on any UK & Ireland television broadcast companies (i.e BBC, SKY, CHANNEL 5 etc.) or any other medium must not be used without explicit agreement from Alan Gow ([alan.gow@btcc-toca.com](mailto:alan.gow@btcc-toca.com)) and ITV. Rights clearance will need to be obtained from ITV ([sportarchiveproducers-group@itv.com](mailto:sportarchiveproducers-group@itv.com)) and a rights-fee will also apply.

Footage to be broadcast on any medium outside of the UK & Ireland, must first obtain rights clearance from Alan Gow. However, the actual footage must still be acquired from ITV.

Circuits using footage to advertise their BTCC event will not be charged a rights-fee but may incur the technical costs of providing footage.

## **2026 MINI CHALLENGE Trophy Sporting & Technical Regulations**

### **6.17. PRESS RELEASES**

All driver and team press releases and social media posts quoting MINI CHALLENGE must be submitted to the MINI CHALLENGE for approval prior to release. Contact [Media@minichallenge.co.uk](mailto:Media@minichallenge.co.uk).

### **6.18 AVAILABILITY OF CARS**

- 6.18.1 Cooper Conversion kits are available from Total Track Ltd to enable drivers and teams to build their own cars. All cars must be approved by the Organisers to be accepted to race in the MINI CHALLENGE Trophy and will/will not be accepted entirely at the Organisers discretion.

**2026 MINI CHALLENGE Trophy Sporting  
& Technical Regulations**

**7 CHAMPIONSHIP OFFICIALS**

**Championship Coordinator**

**Rhea Beauchamp**

Unit 1  
Roy Humphrey Estate  
A140 Norwich Ipswich Road  
Brome  
Eye  
Suffolk  
IP23 8AW

Office Tel: 07795 007469  
Email: [rhea@minichallenge.co.uk](mailto:rhea@minichallenge.co.uk)  
Website: [www.minichallenge.co.uk](http://www.minichallenge.co.uk)

**Championship Technical Director**

**Andy Menzies**

Unit 1  
Roy Humphrey Estate  
A140 Norwich Ipswich Road  
Brome  
Eye  
Suffolk  
IP23 8AW

Office Tel: 07854 872611  
Email: [andy@minichallenge.co.uk](mailto:andy@minichallenge.co.uk)  
Website: [www.minichallenge.co.uk](http://www.minichallenge.co.uk)

**Championship MOTORSPORT UK Eligibility Scrutineer**

**Steven Fitzgerald**

Unit 1  
Roy Humphrey Estate  
A140 Norwich Ipswich Road  
Brome  
Eye  
Suffolk  
IP23 8AW

Email: [technical@minichallenge.co.uk](mailto:technical@minichallenge.co.uk)  
Website: [www.minichallenge.co.uk](http://www.minichallenge.co.uk)

**2026 MINI CHALLENGE Trophy Sporting  
& Technical Regulations**

**British Automobile Racing Club**

**David Wheadon**

BARC  
Thruxton Circuit  
Andover  
Hampshire  
SP11 8PN

Tel: 01264 882207  
Email [dwheadon@barc.net](mailto:dwheadon@barc.net)

**Motorsport UK**

Motorsport UK House  
141 Command Works  
Bicester Heritage  
Bicester  
OX27 8FY  
Tel: 01753 765 000  
Website: [www.motorsportuk.org](http://www.motorsportuk.org)

**2026 MINI CHALLENGE Trophy Sporting  
& Technical Regulations**

**Appendix A – Technical Query Form**



**Technical or Sporting Query Form**

Car No:		Date:	
Chassis No:		Class:	
Driver/Entrant Name:		Signature:	
Request: (One request only per form)			
Reply:			
Date:		Position:	
Name:		Signature:	

**2026 MINI CHALLENGE Trophy Sporting  
& Technical Regulations**

**Appendix B: Total Track Ltd - Power Test Authorisation**



**Power Test Authorisation**

Whilst every care will be taken so as not to cause damage to a competitor's car/engine Total Track Ltd cannot accept responsibility for damage resulting from participating in a Power Test.

Specifically, Total Track Ltd cannot accept responsibility for damage to engines due to heat soak.

In the event that Total Track's equipment or premises is damaged due to the failure of a components on a competitor's car or engine, the cost of repairing Total Track's equipment will be borne by the competitor.

The cost of cleaning fluid leaks will be borne by the competitor.

The operation of Dyno equipment is dangerous and Total Track does not accept responsibility for injury or loss of life caused by its operation.

Competitors will be required to pay for the cost of testing immediately after the test run has completed. Only card payments will be accepted, no cheques or cash.

I the undersigned accept the above terms.

Name: .....

Signature: .....

Date: .....

Email Address: .....

**2026 MINI CHALLENGE Trophy Sporting  
& Technical Regulations**

**Appendix C: Approved Data Loggers**

All Cosworth systems with GPS puck but no other additional sensors

AIM Solo 2 DL systems with GPS puck but no other additional sensors

AIM Solo 2 DL systems with AIM SmartyCam and GPS puck but no other additional sensors

All VBox systems with a GPS puck but no other additional sensors

## 2026 MINI CHALLENGE Trophy Sporting & Technical Regulations

### Appendix D: Motorsport UK - Race With Respect

A socially-minded standard of behaviour is expected from everyone within the motorsport community.

By participating in a Motorsport UK event in any capacity you agree to follow the values of the Respect Code:

#### The Values

- Respect
- Integrity
- Fair play
- Good Manners
- Self-Control

I pledge to #RaceWithRespect and:

- Contribute to a welcoming and friendly environment that ensures the safety and welfare of all participants.
- Always behave with integrity and uphold fairness in the sport; play my part in keeping the sport safe through my actions
- Treat everyone with respect, regardless of their gender, ethnic or social background, language, religious or other beliefs, disability, sexual identity or other status
- Recognise that we all represent the sport and therefore have a duty to be polite and respectful to all staff, officials, fellow competitors, volunteers, as well as fans and supporters
- Respect the rules, regulations and authority of the officials and Motorsport UK

Any breach of these obligations may result in disciplinary action.

**2026 MINI CHALLENGE Trophy Sporting  
& Technical Regulations**

**Appendix E – Technical Log Book**



**Technical Log Book**

<b>Vehicle, Team &amp; Driver</b>			
Car No:		Driver Name:	
Entrant Name:		Team Manager Name:	
<b>Seal Numbers</b>			
Engine Cam Cover Seal Number:		Engine Sump Seal Number:	
ECU:		Gearbox Seal Number:	
<b>Vehicle</b>			
Base Car Weight Car (No Ballast & 3 L fuel) (Kg):		Fire Extinguisher last serviced by approved agent date:	
Ballast Weight (Kg):		Seat FIA Homologation Expiry Date:	
<b>On Board Cameras</b>			
Front Camera Make and Model:		Rear Camera Make and Model:	
<b>Data Logger</b>			
Data Logger Make and Model (see Appendix c)			
Connected to CANBUS?			

**2026 MINI CHALLENGE Trophy Sporting  
& Technical Regulations**

<p>I, the undersigned entrant/competitor confirm that the car referred to in this logbook is prepared in line with and fully complies with the Championship Regulations.</p> <p>I, the undersigned entrant/competitor confirm that no parts have been modified other than where specifically allowed by these regulations or to repair the part as detailed in this logbook.</p> <p>I, the undersigned entrant/competitor also confirm that the ECU and all other parts listed in the log book above have been delivered to me and that no changes have been made to any of these components since delivery, and that all seals/serial numbers remain intact and that all components fully comply with the Championship Regulations.</p> <p>I, the undersigned entrant/competitor confirm that chassis is in accordance with the Championship Regulations, and that all components fitted fully comply with the Championship Regulations and that any repairs that required welding have been carried out by Total Track Ltd or its nominated agent as detailed above.</p> <p>I, the undersigned entrant/competitor confirm that the dampers fitted are in accordance with the Championship Regulations and that no modifications have been made and that any repairs and servicing have been carried out by Total Track Ltd or its nominated agent.</p> <p>I, the undersigned entrant/competitor confirm that the gearbox and differential fitted are in accordance with the Championship Regulations and that any repairs and servicing has been carried out in line with these regulations and that no modifications have been made.</p> <p>I, the undersigned entrant/competitor confirm that if any of the above components are changed/repaired/serviced that the Technical Log Book will need to be completed and submitted and a new Calibration Certificate will be obtained.</p> <p>I, the undersigned entrant/competitor confirm that the seat is in a safe and usable condition and fitted in accordance with the manufacturers instructions.</p>
---

Entrant Signed:	
Entrant Name:	
Date:	
Competitor Signed:	
Competitor Name:	
Date:	

I, the Championship Eligibility Scrutineer confirm receipt of this Technical Log Book:

Signed:	
Name:	
Date:	